

UM

BLOW MOLDING SPARE PARTS FOR MACHINES BRANDED SIDEL*



Our partners :



Covirep Sa







*UM is not a license of Sidel nor have UM parts been approved or authorized by Sidel.







SECTIONS

Click on this logo for more information 

Entry wheel

-  Entry modules
-  Entry wheel
-  Infeed guide
-  Tri sector



Oven

-  Ejector
-  Guide & turnover cam
-  Lamp
-  Oven chain S1,S2 & Universal
-  Oven exit guide
-  Spindle tip

Transfer wheel

-  Gripper
-  Transfer arm gripper holder

Blowing wheel

-  Bell
-  Blow nozzle S2
-  Cam

4

5

6

7

9

10

11

12

18

19

22

24

26

27

29

-  Compensation valve

-  Matrix blowing block

-  Molds

-  Mold hanger

-  Pneumatic mold base

-  Rotary union S1, S2 & Universal

-  Shock absorber & stoping trust

-  Stretch rod clamp

-  Stretch rod cylinder S2

-  Transmission belt

-  Universal station

-  Valve S2 & Universal

Other

-  Other parts available

30

31

34

35

37

38

42

43

45

46

48

51

58

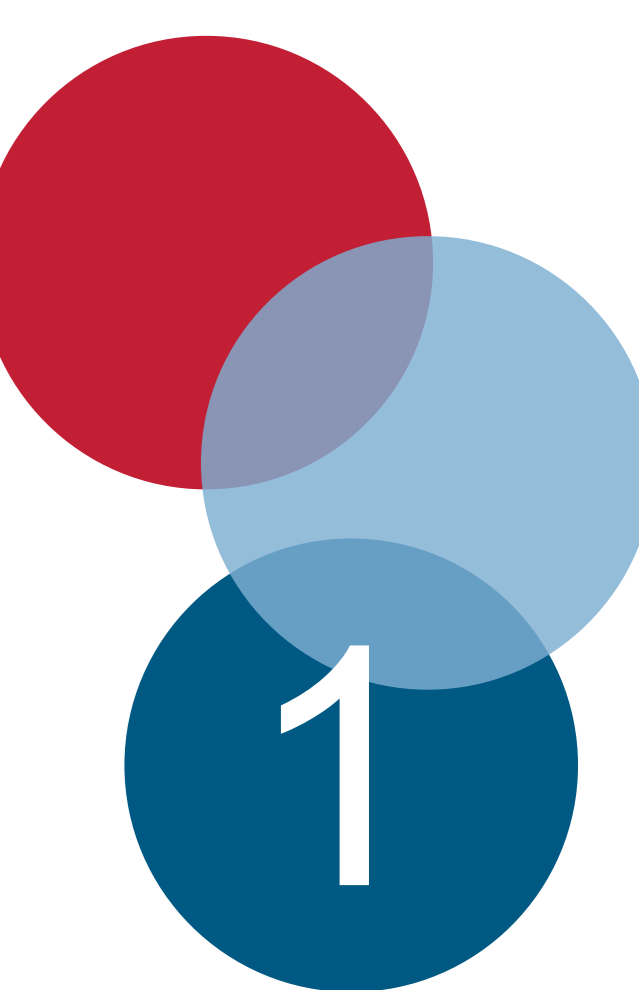



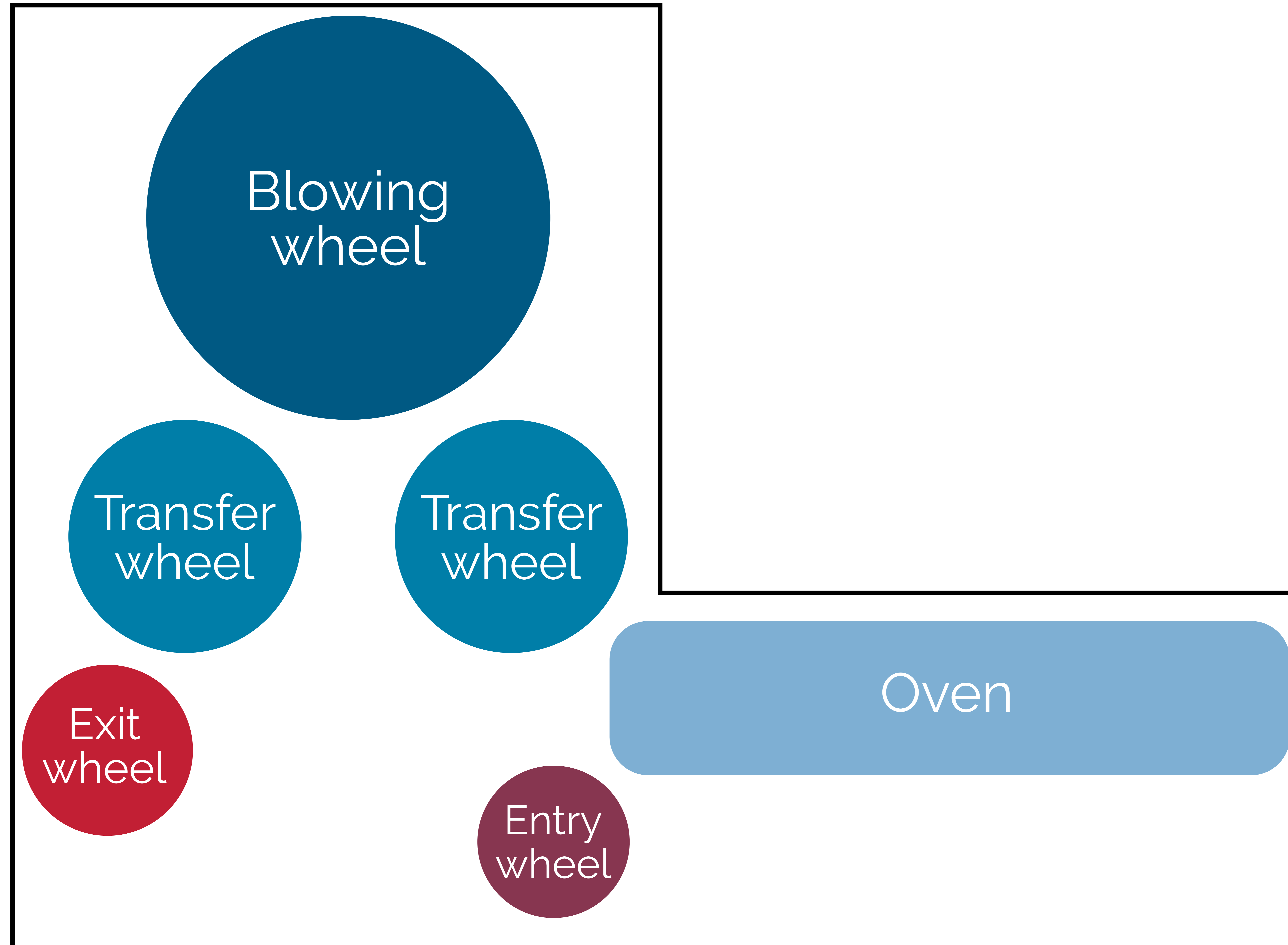

SECTIONS

Click on the desired section to see the parts available



ENTRY WHEEL

-  Entry modules
-  Entry wheel
-  Infeed guide
-  Tri sector

4

5

6

7

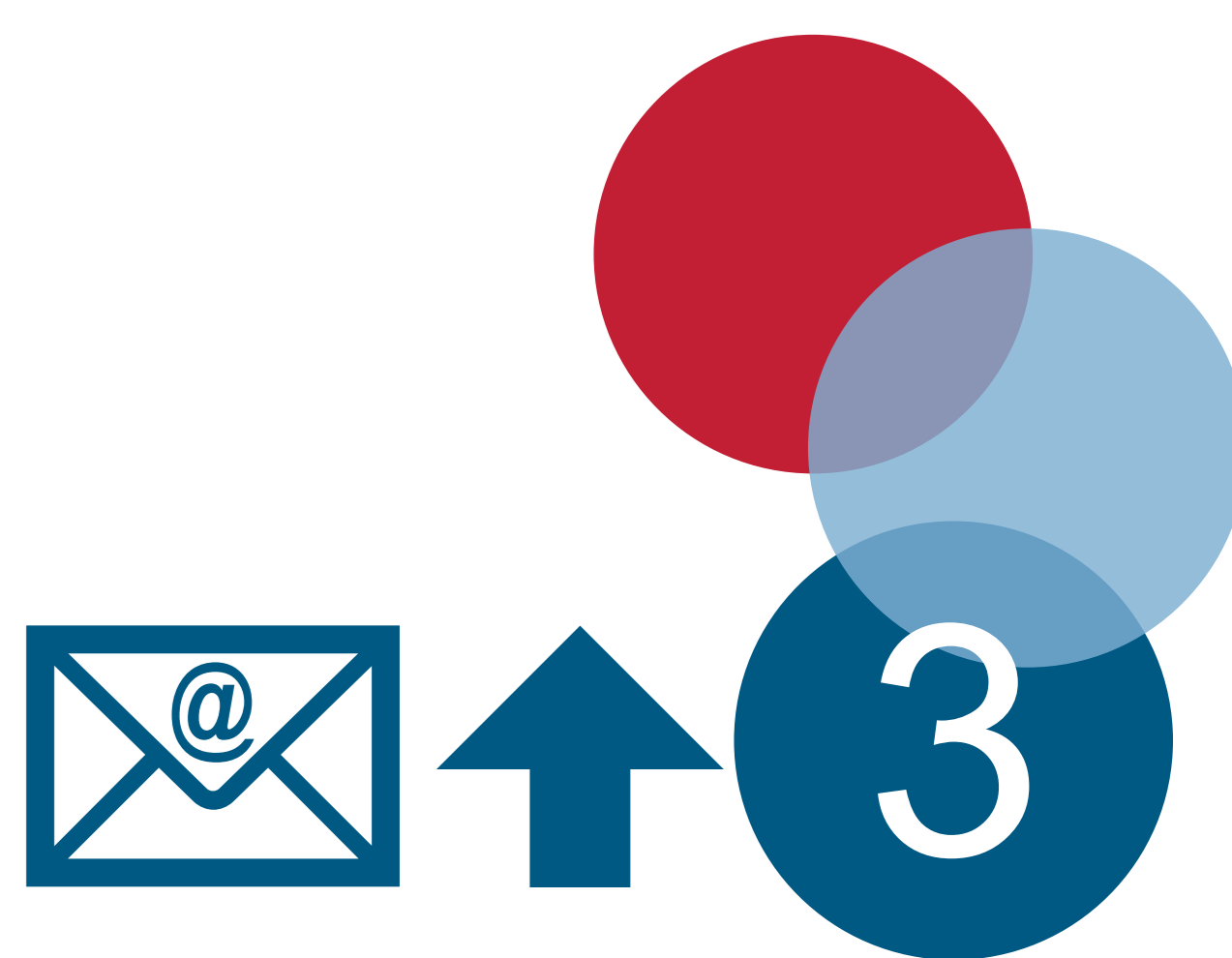

ENTRY MODULES

Form

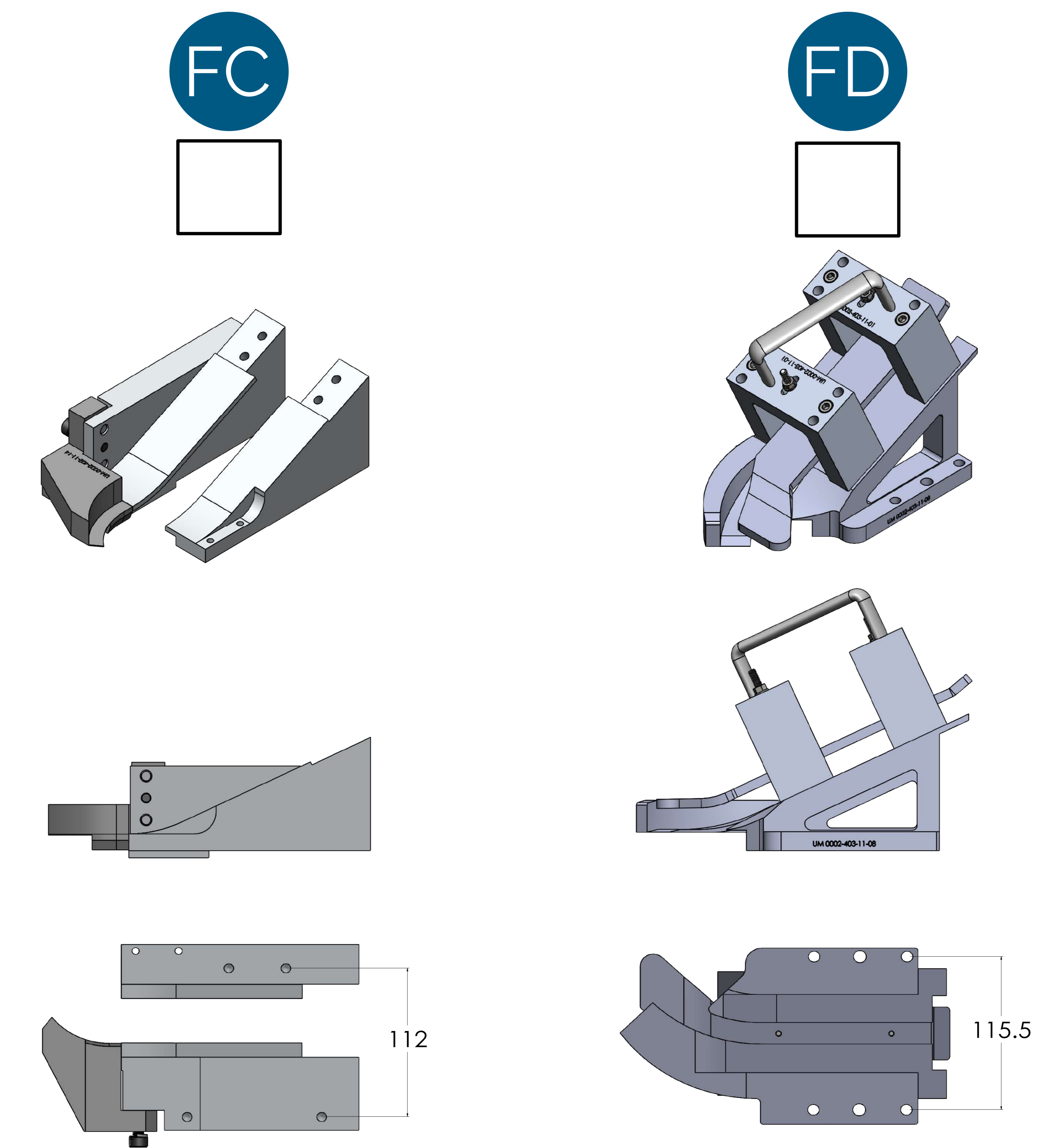
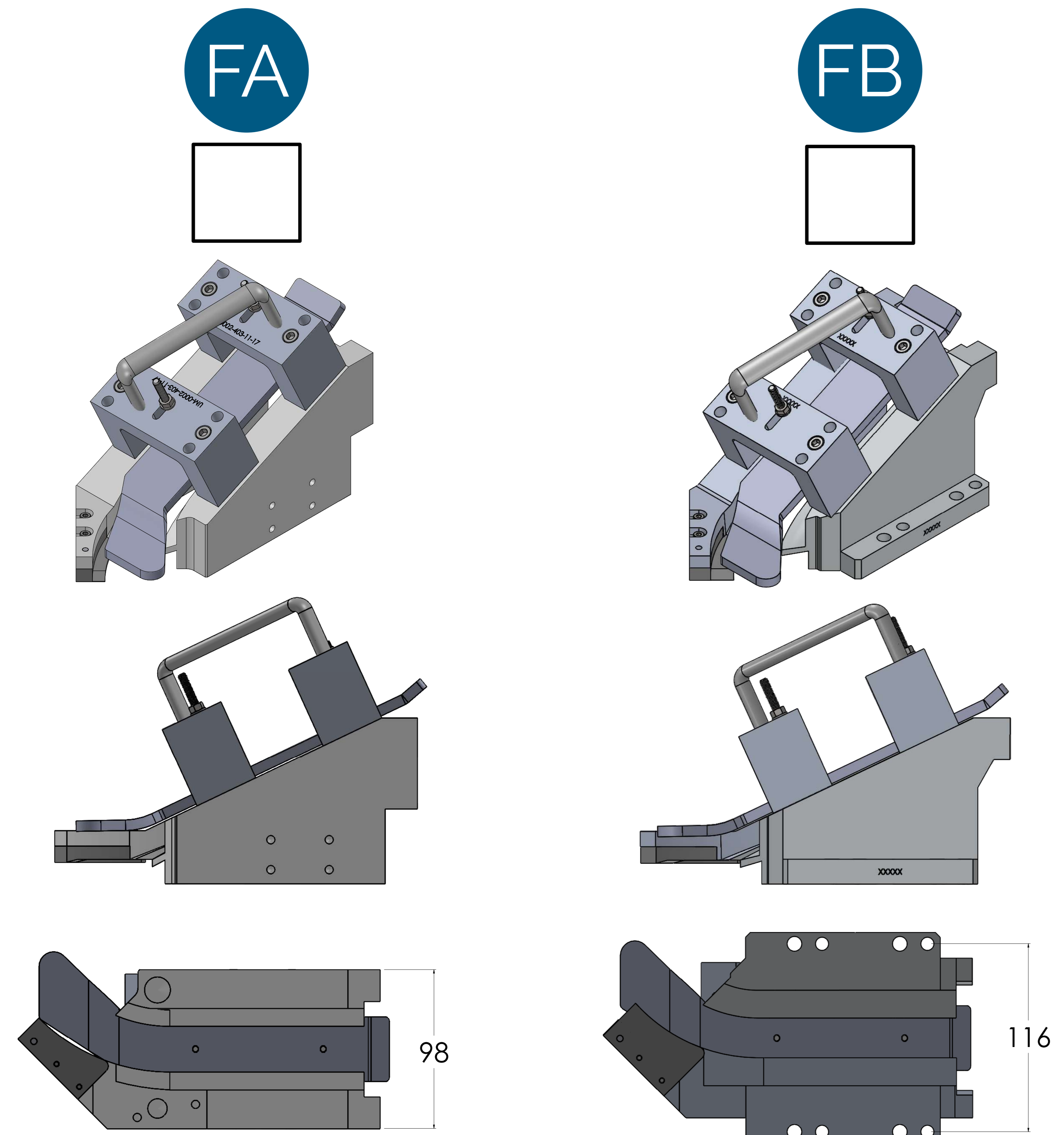

Option

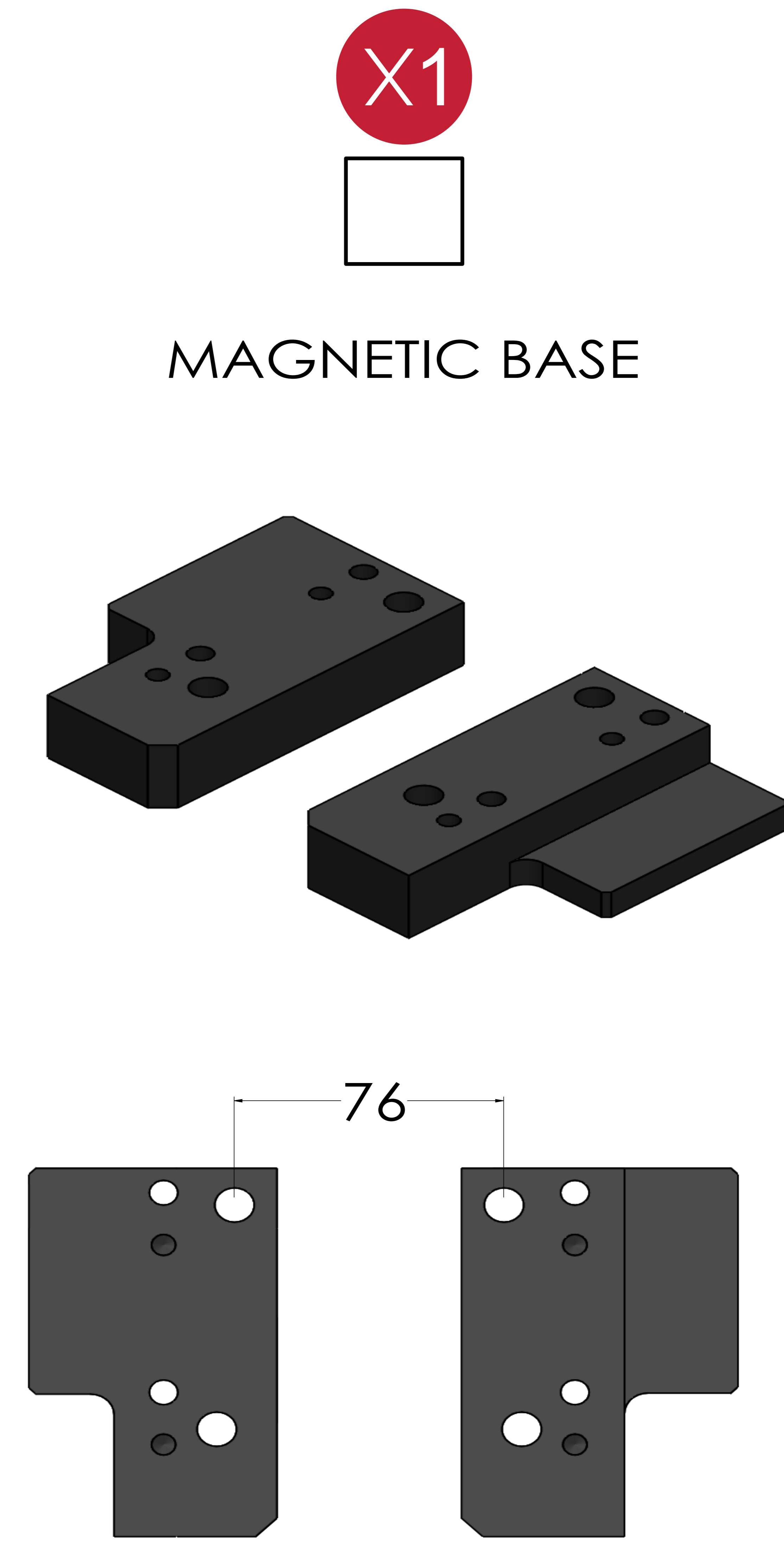

ENTRY WHEEL

FA

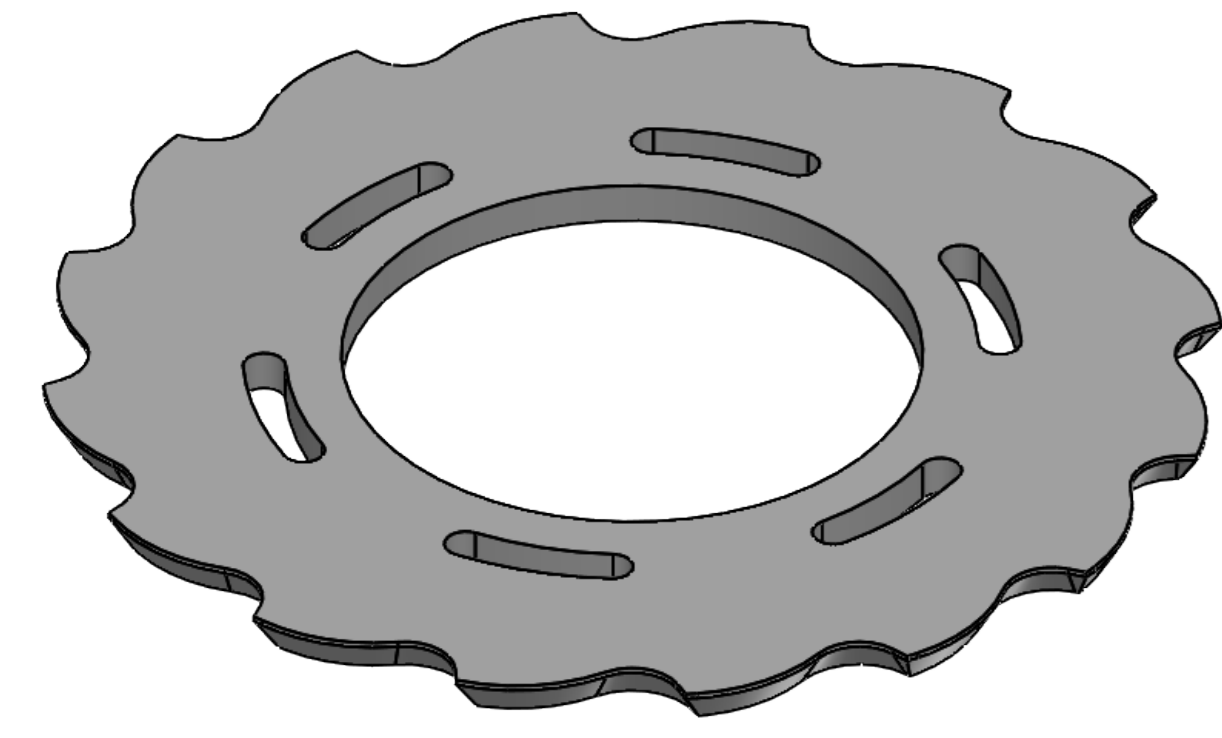
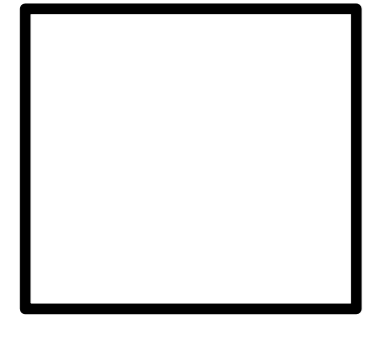

FB

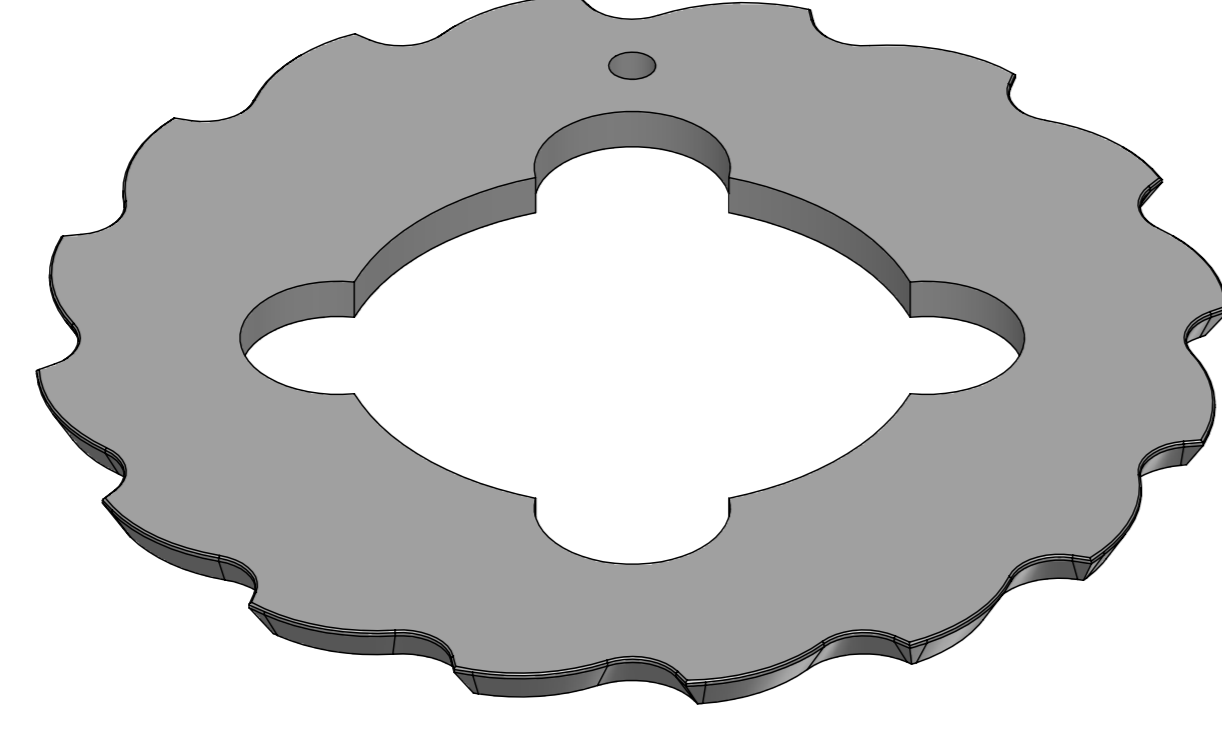
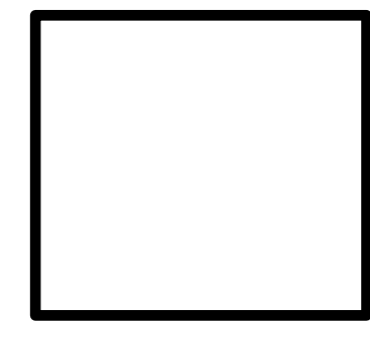

FC

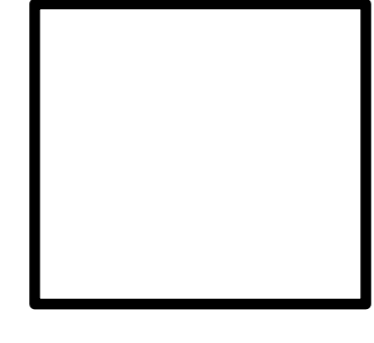

FD

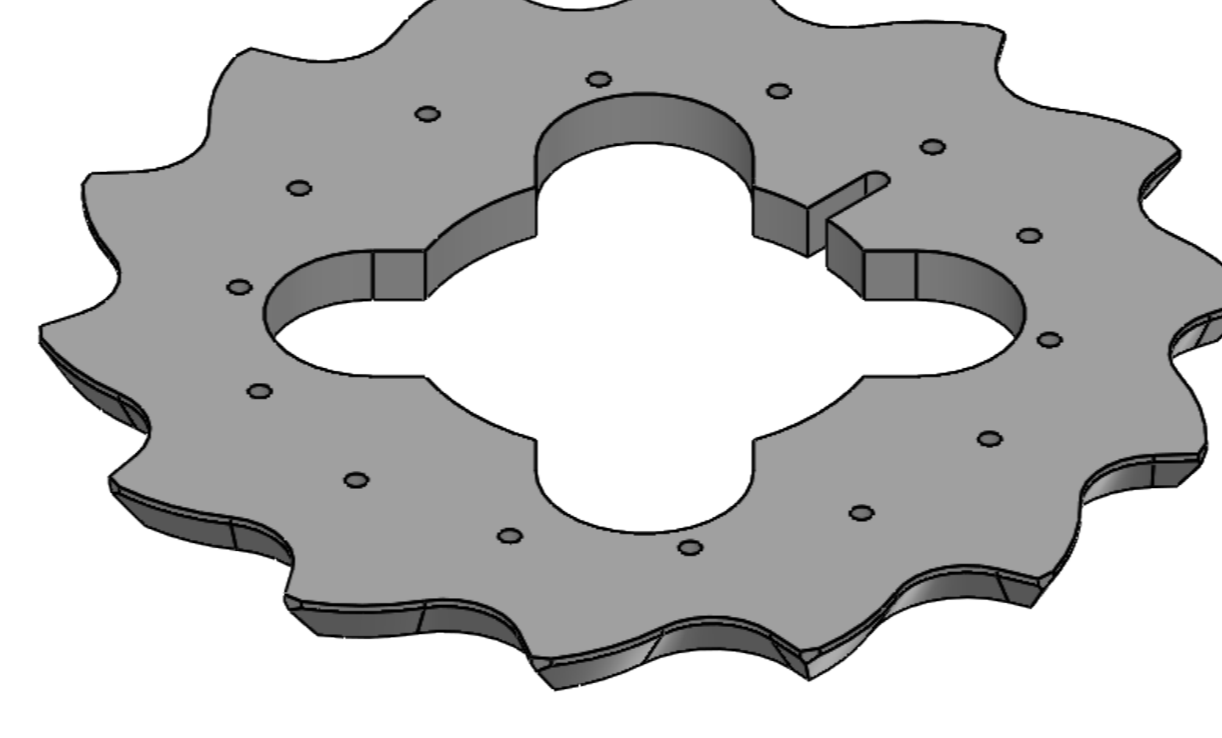
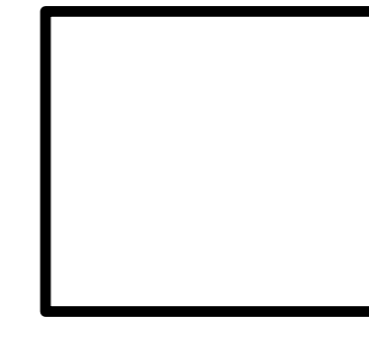

O.D. ϕ 305
I.D. ϕ 150

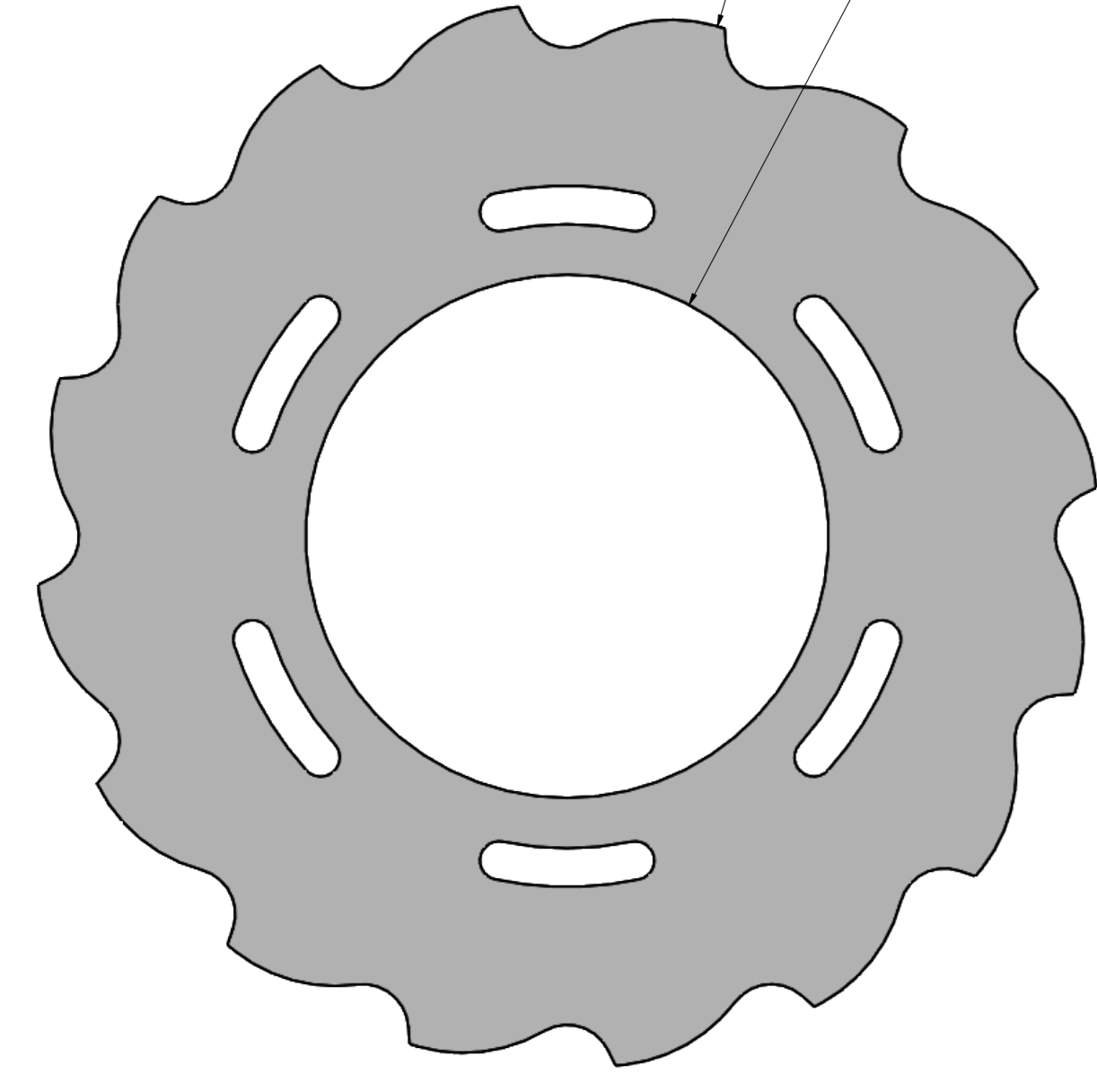

16 TEETH
THICKNESS : 11 mm

OD. ϕ 305
I.D. ϕ 150

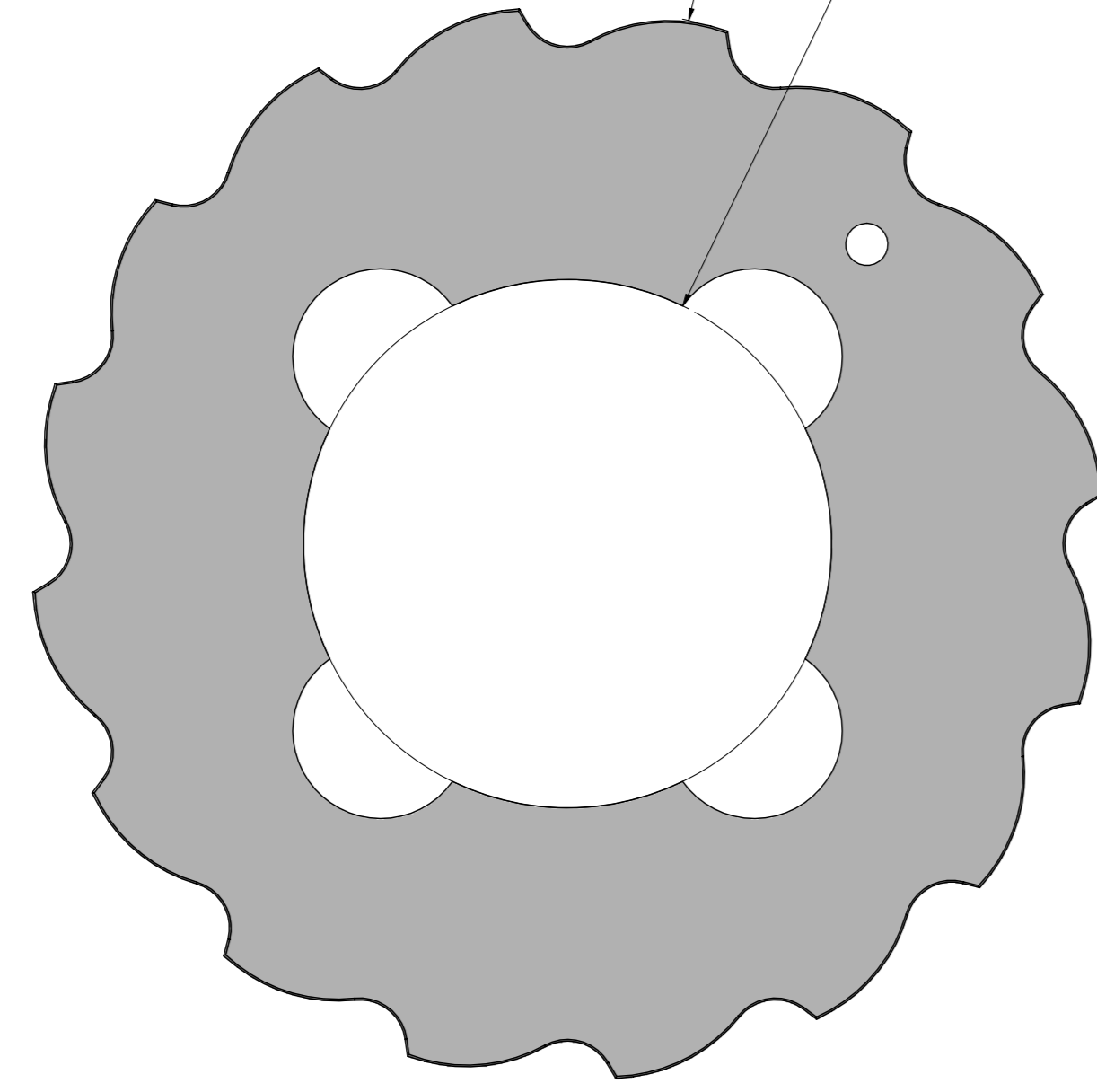

16 TEETH
THICKNESS : 11 mm

ϕ 572.7
 ϕ 420

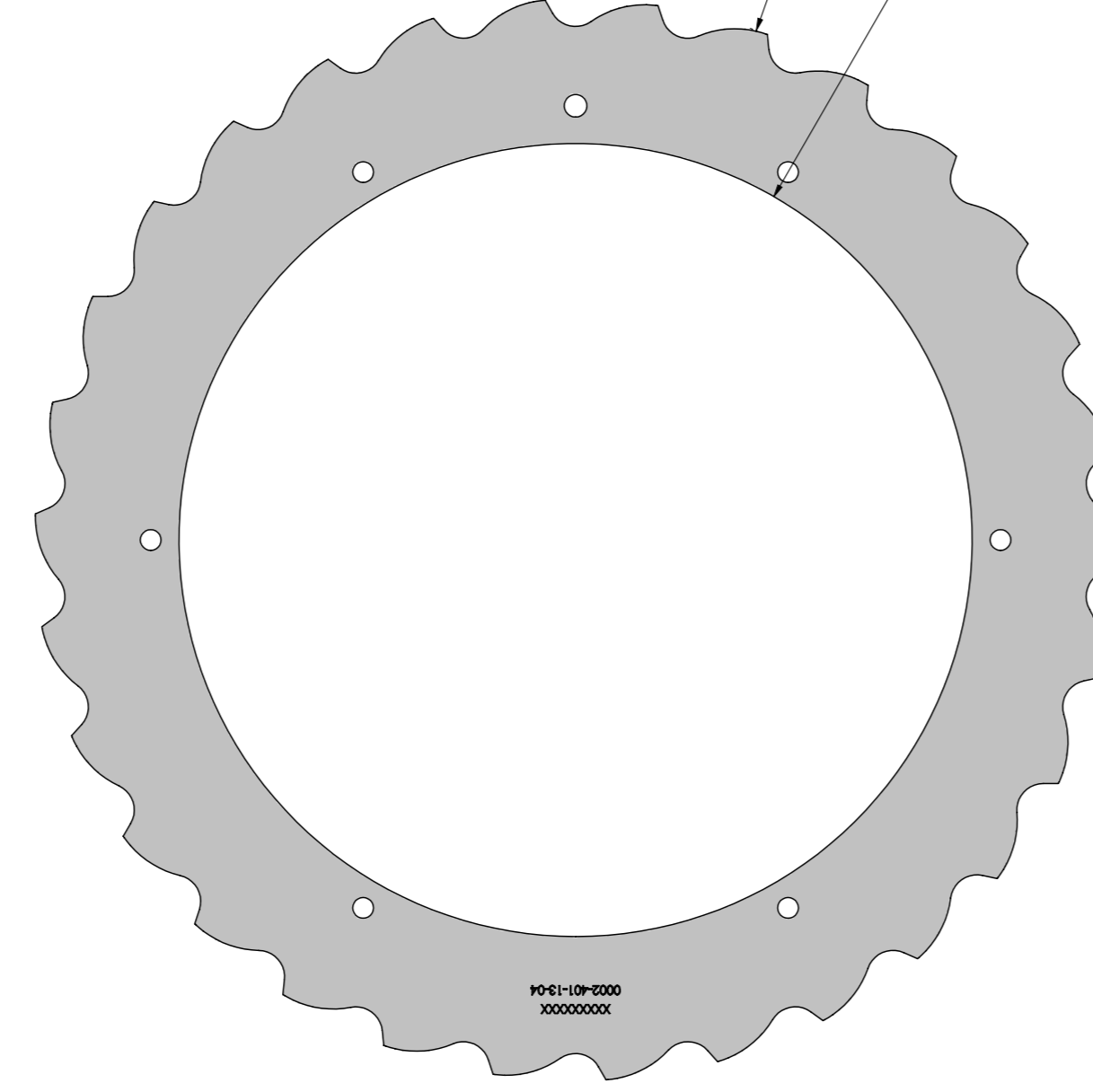

30 TEETH
THICKNESS : 11 mm

ϕ 222.5
 ϕ 90

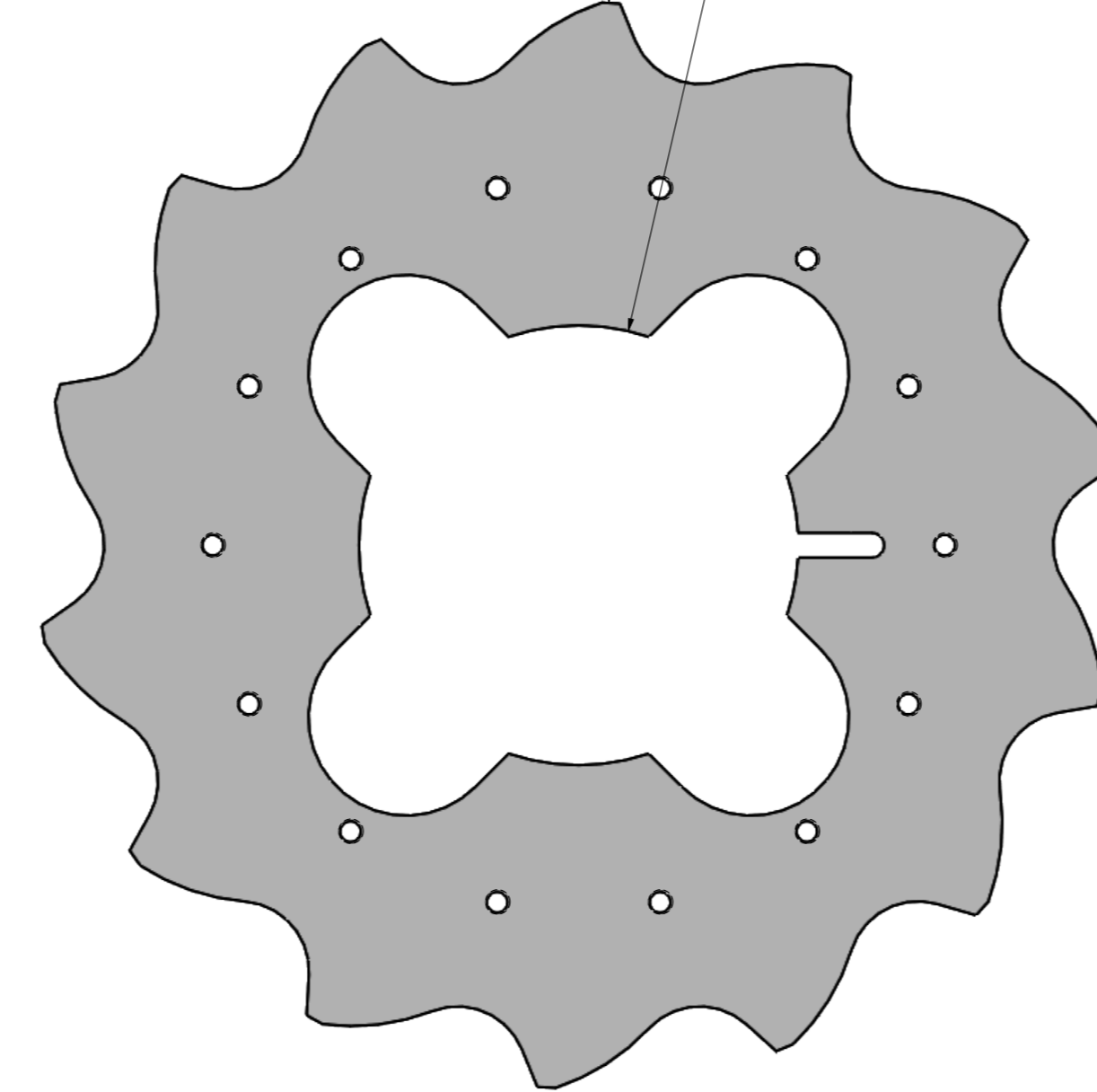

14 TEETH
THICKNESS : 11 mm

FE

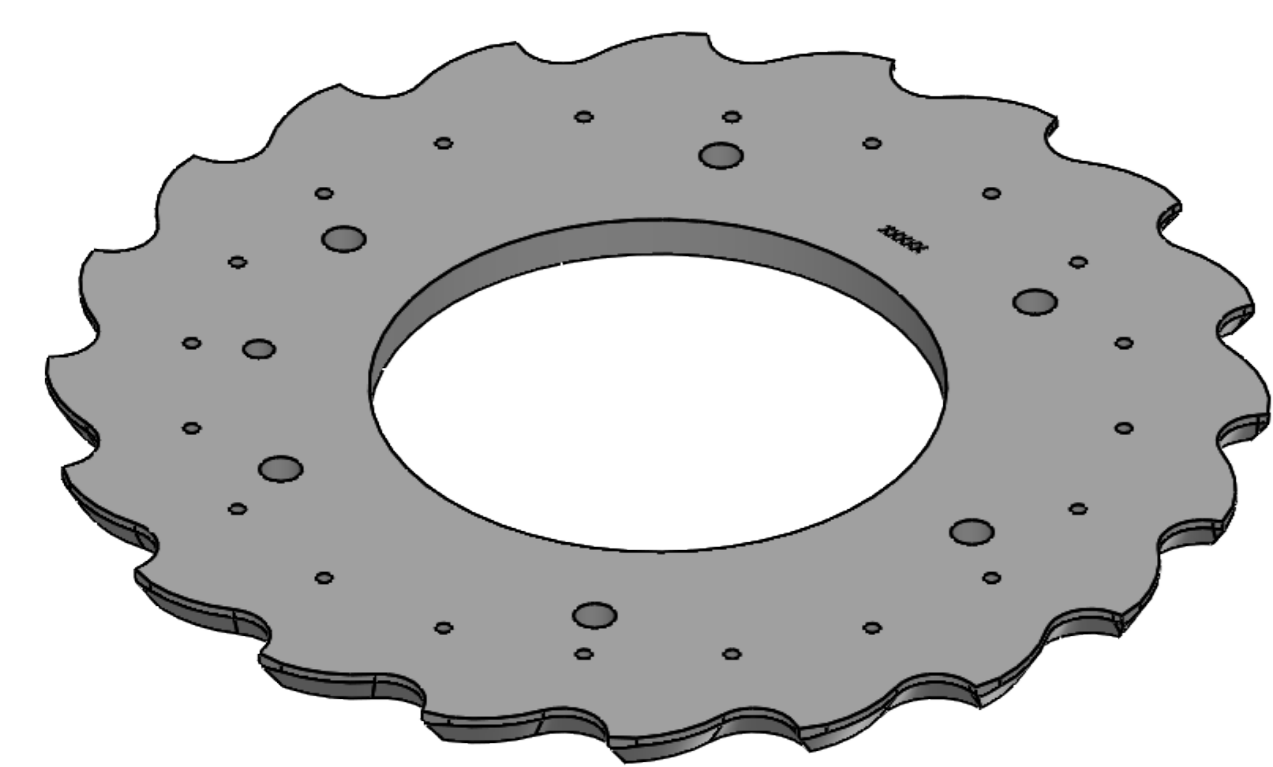
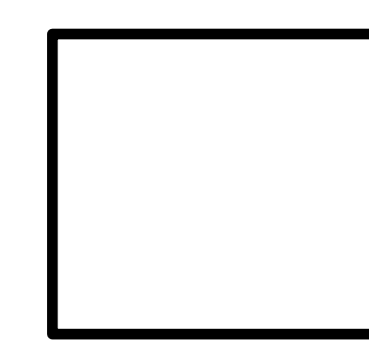

FF

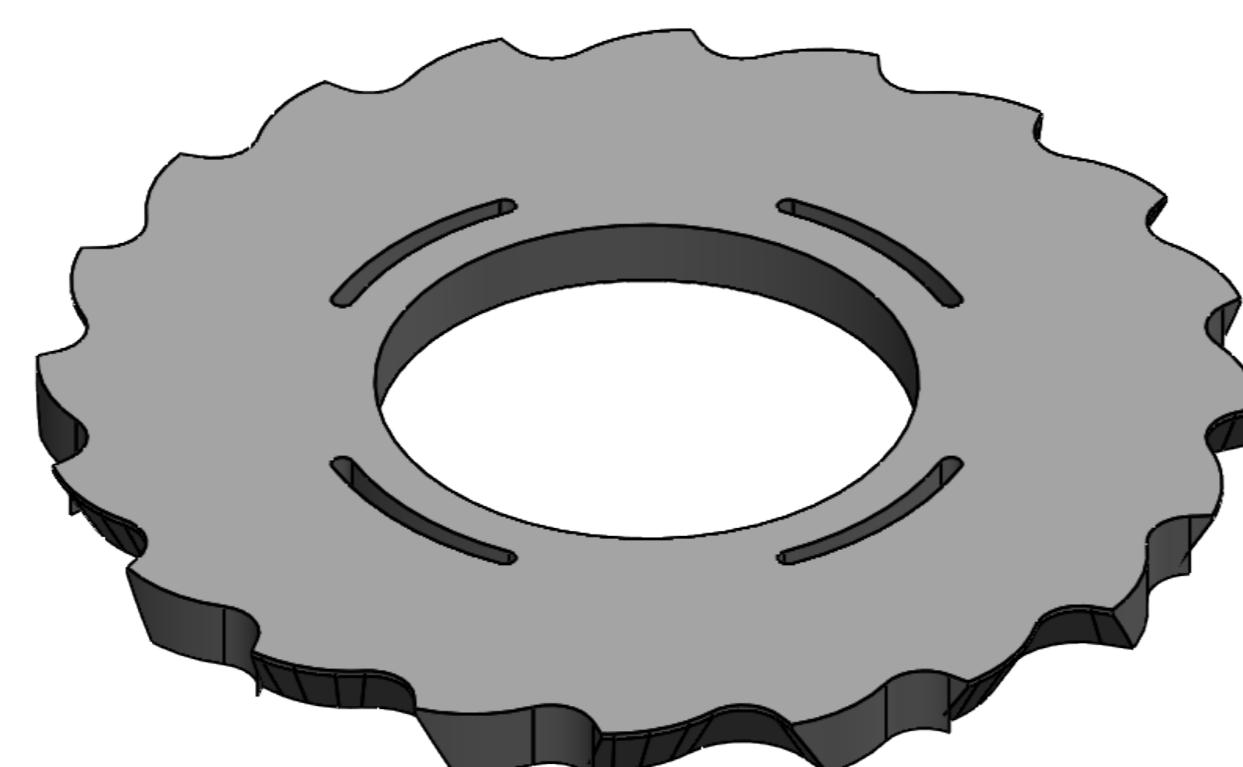
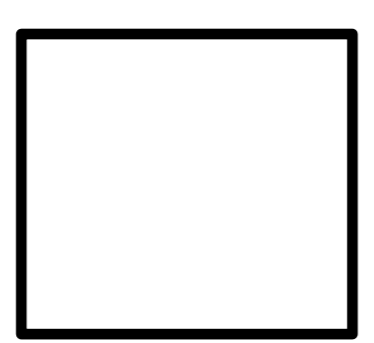

FG

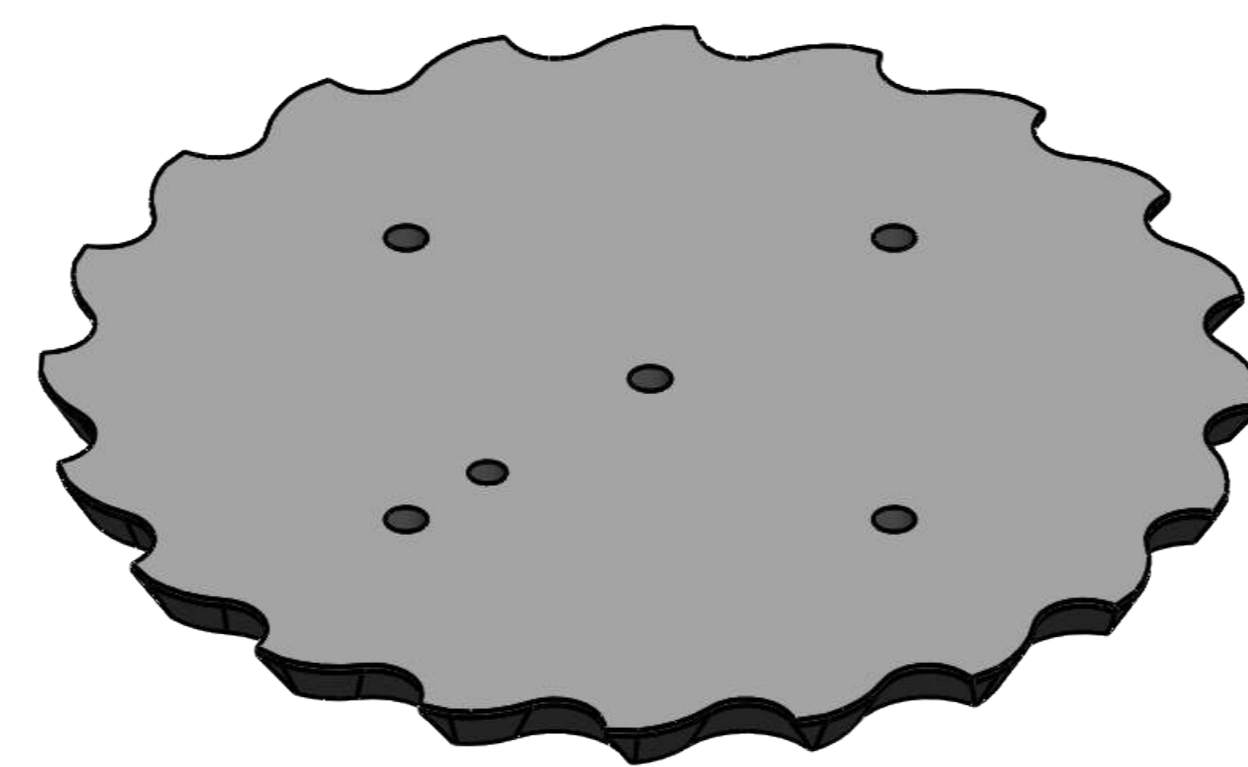
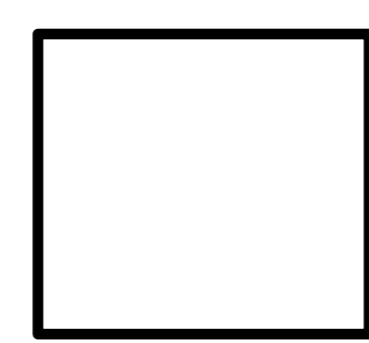

ϕ 318
 ϕ 150

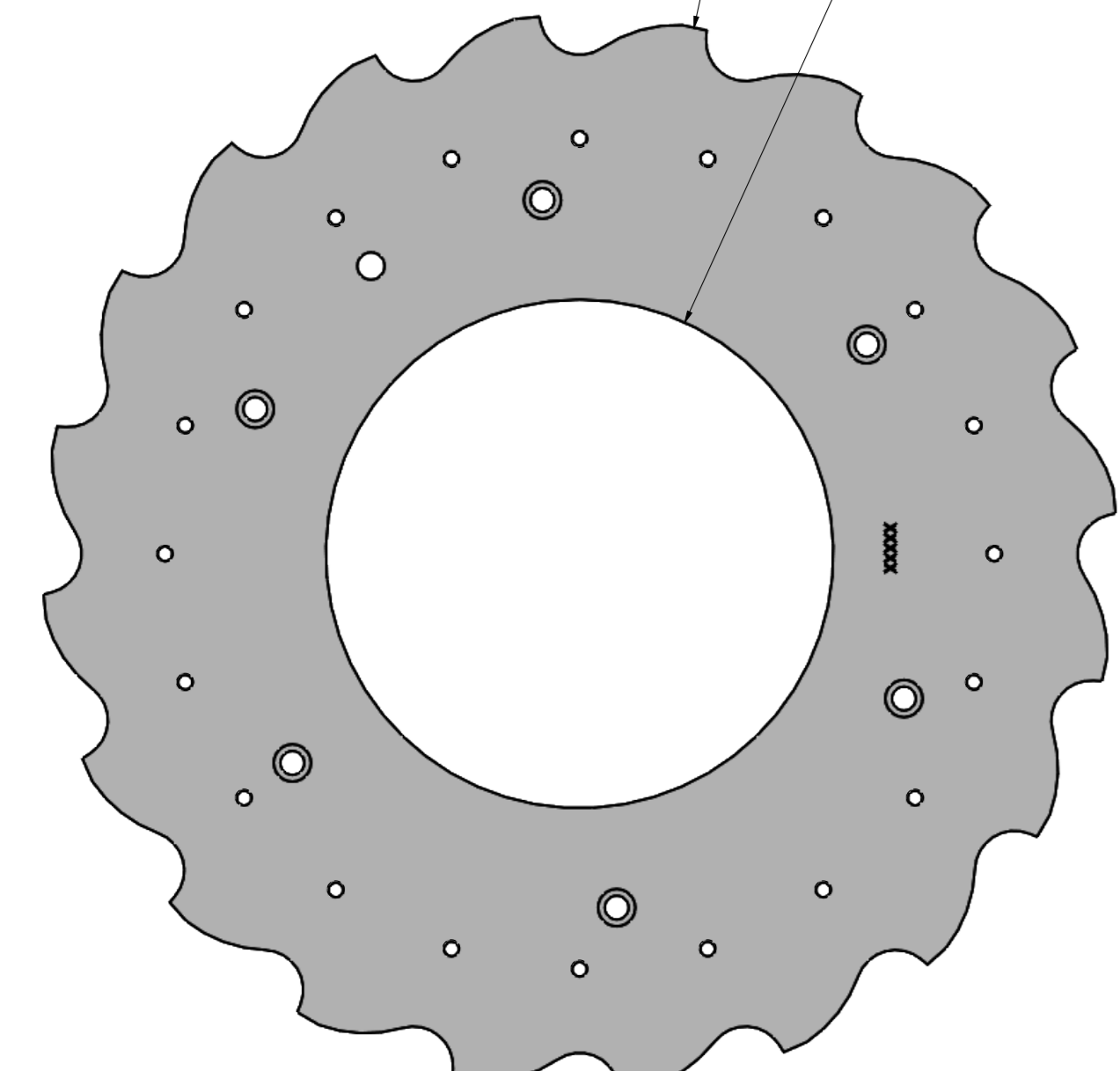

20 TEETH
THICKNESS : 11 mm

ϕ 382
 ϕ 170

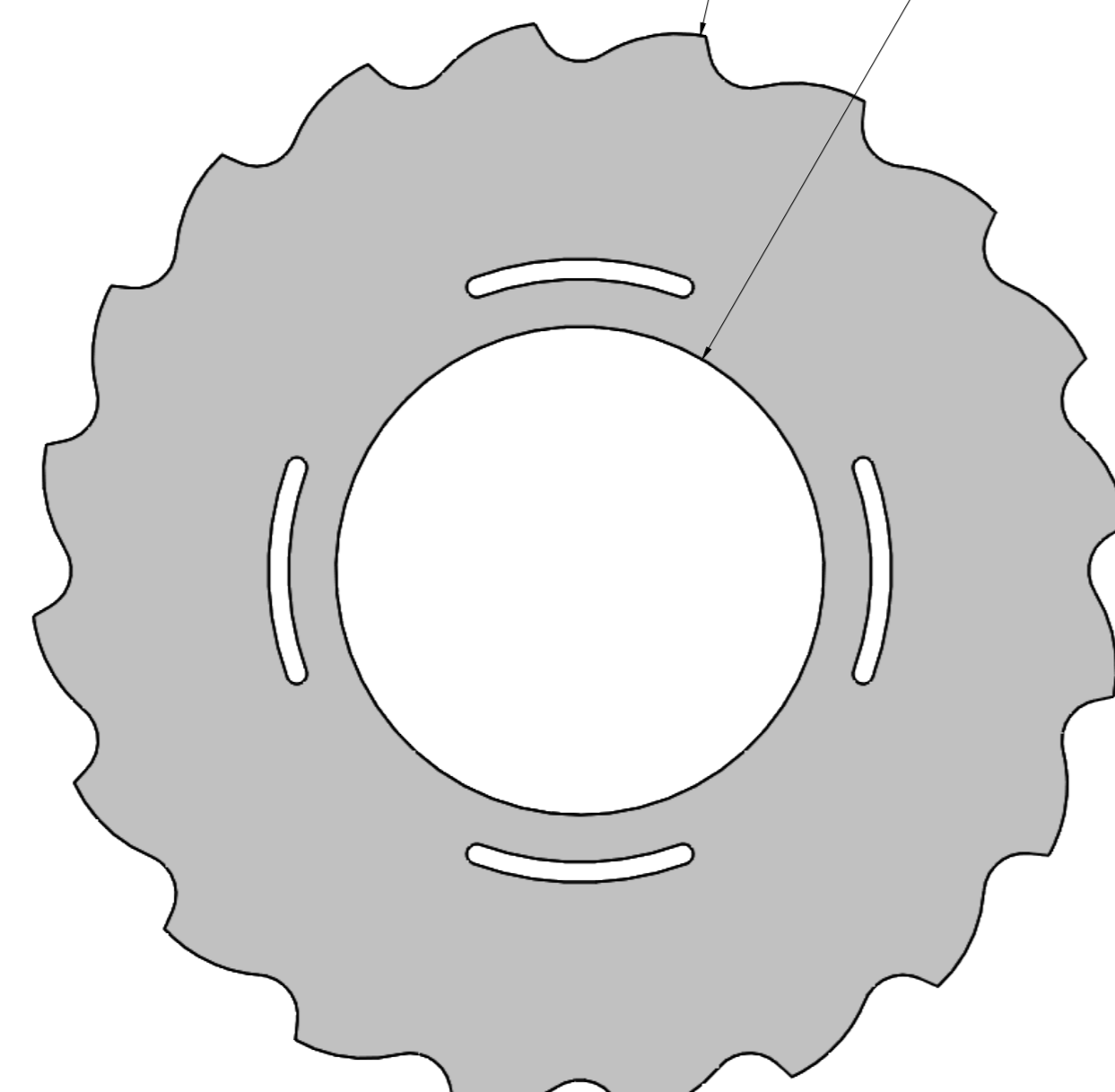

20 TEETH
THICKNESS : 22 mm

ϕ 318
 ϕ 11

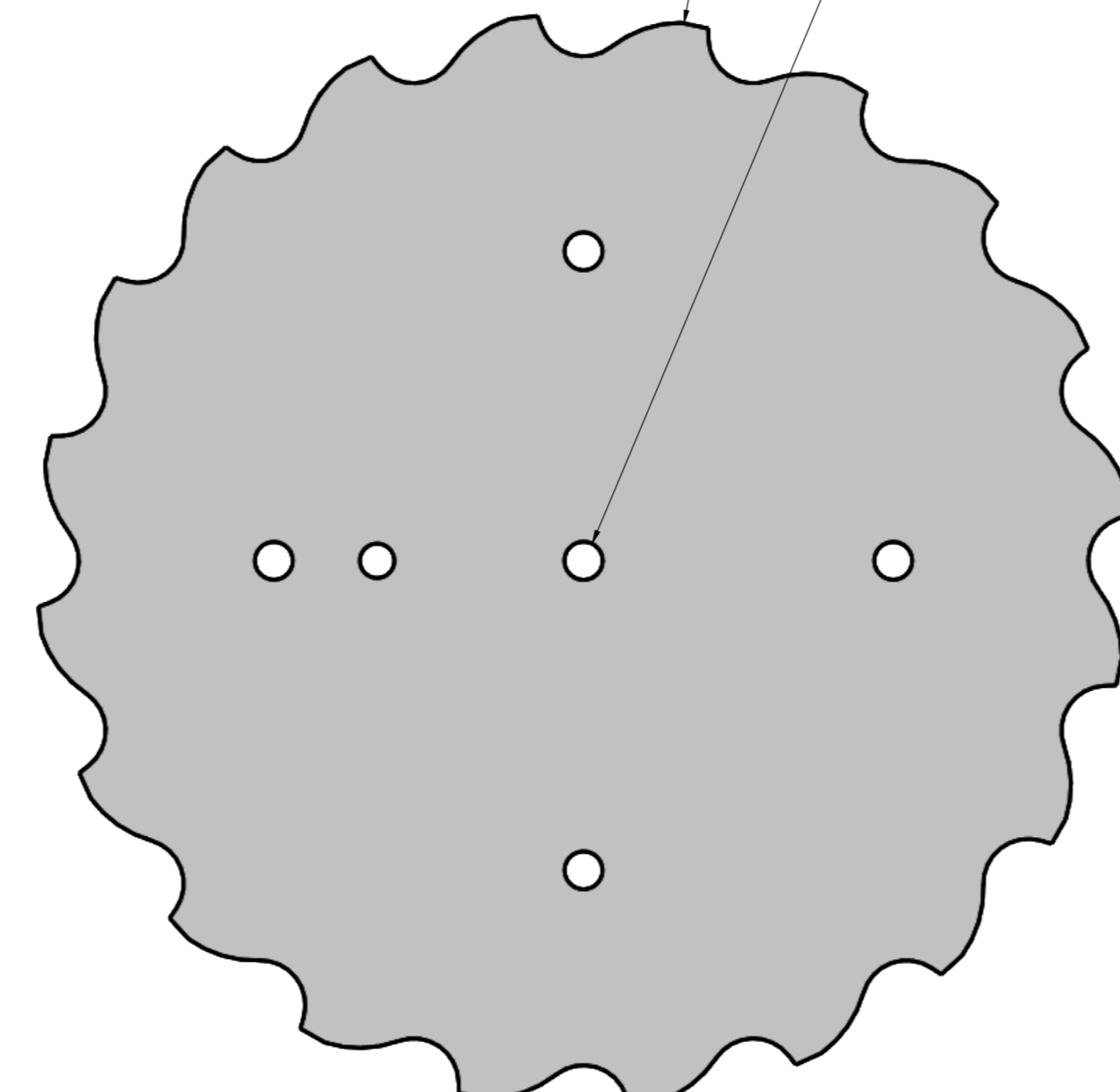

20 TEETH
THICKNESS : 16 mm

X1

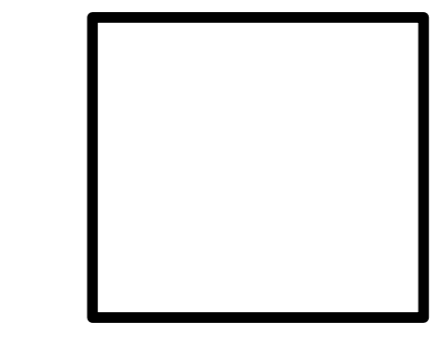

MAGNETIC BASE

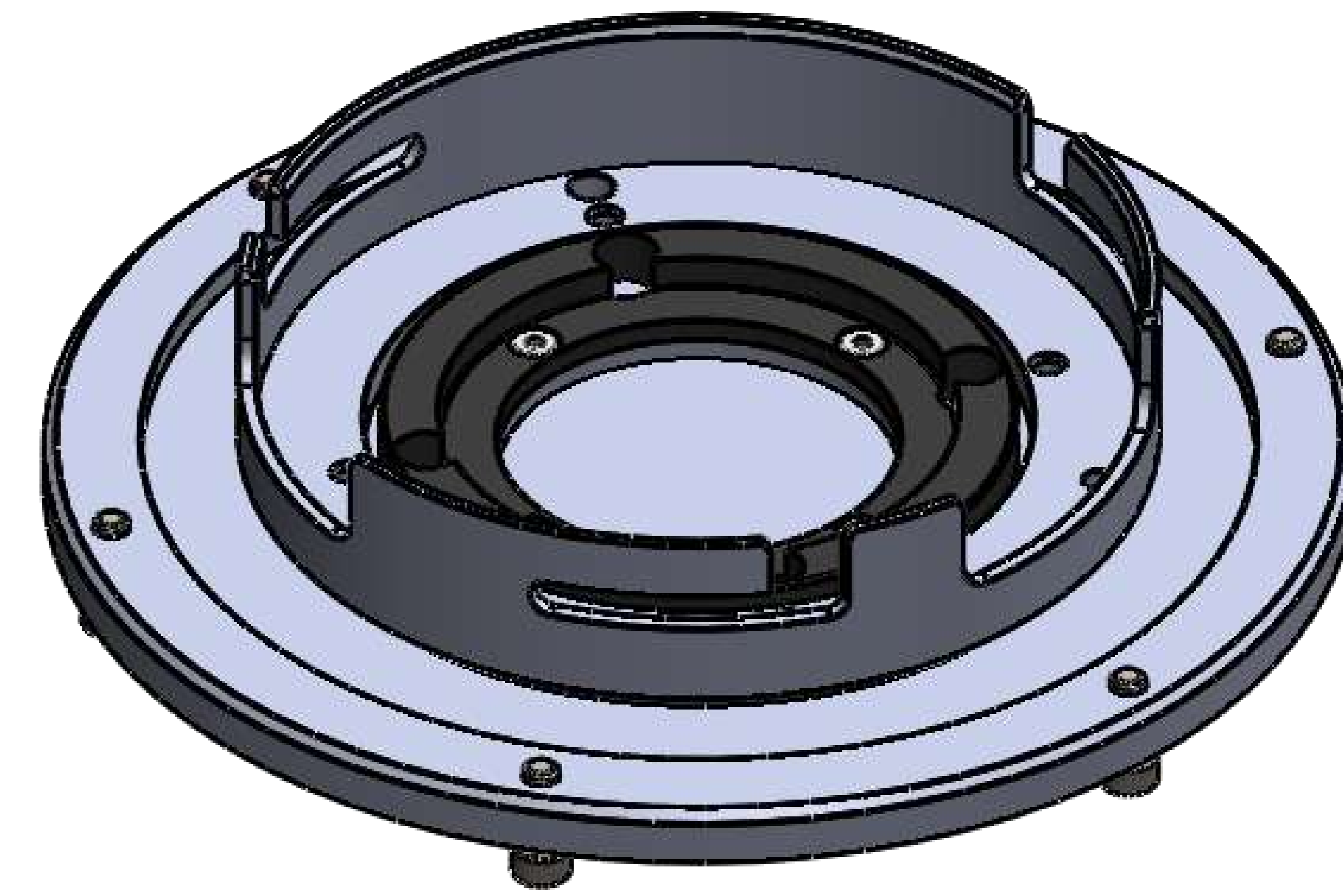

Form

Option

INFEED GUIDE

Form

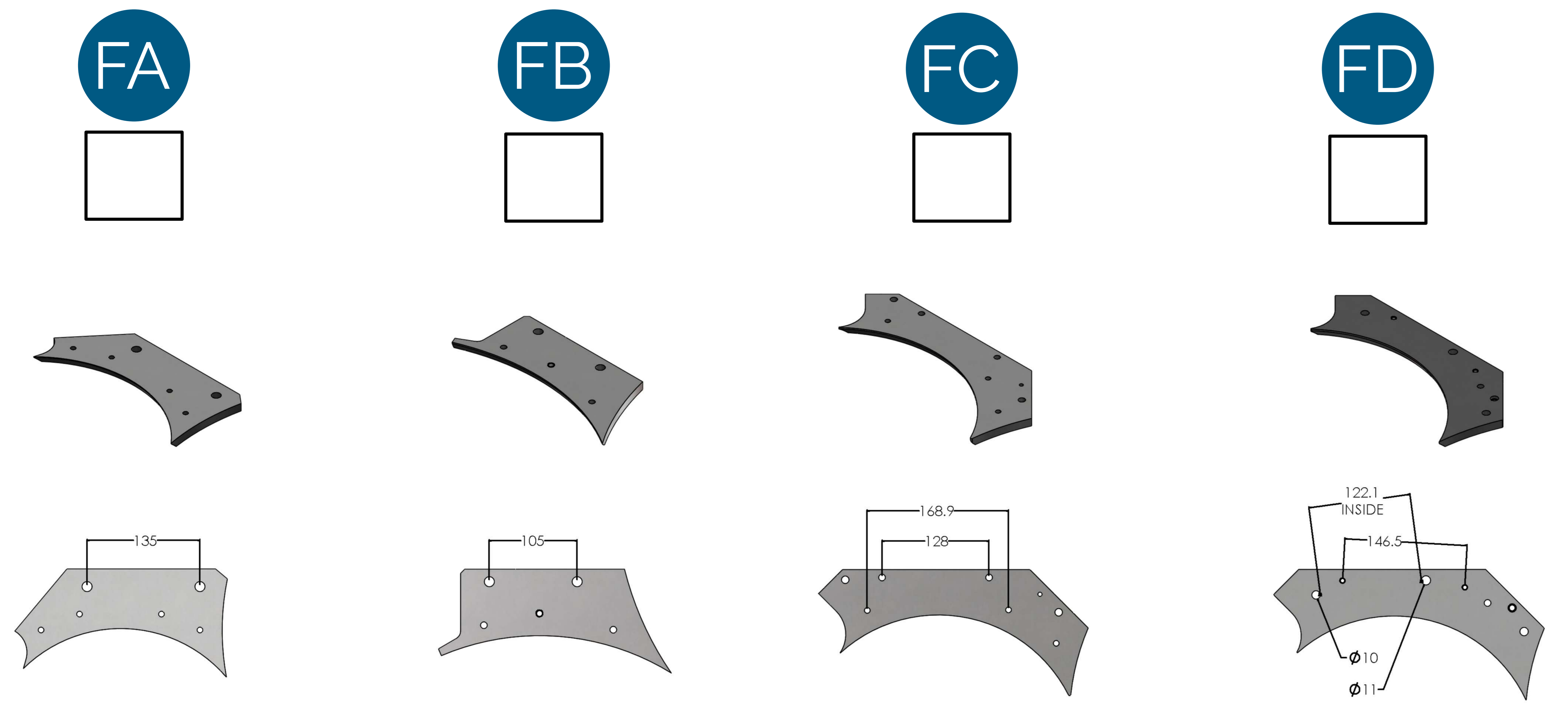

THICKNESS : 11 mm S1 THICKNESS : 11.35 mm S1 THICKNESS : 11 mm S2 THICKNESS : 11 mm UNIVERSAL

Option

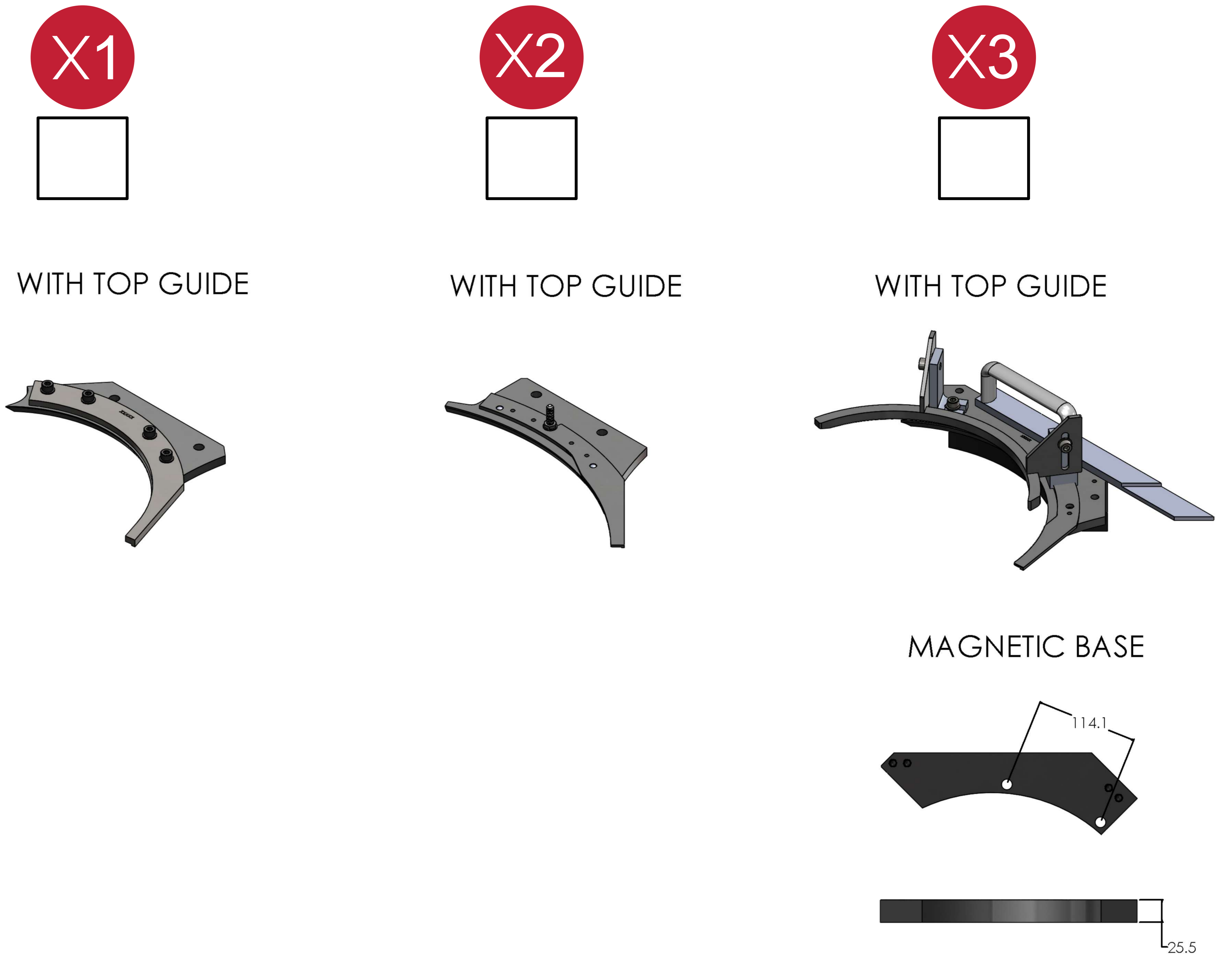

WITH TOP GUIDE WITH TOP GUIDE WITH TOP GUIDE

MAGNETIC BASE

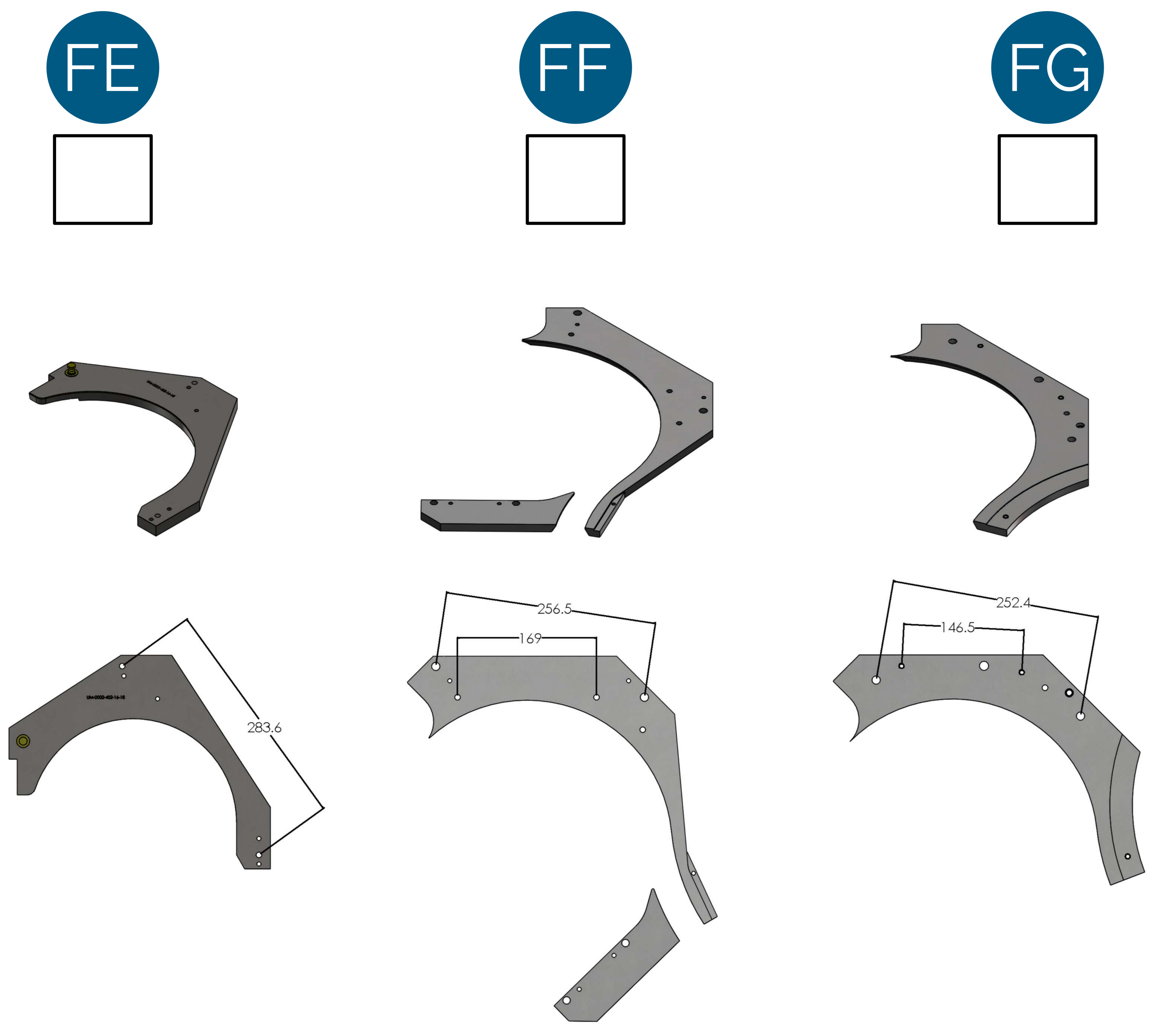

THICKNESS : 15 mm UNIVESAL THICKNESS : 11 mm S2 THICKNESS : 11 mm UNIVERSAL

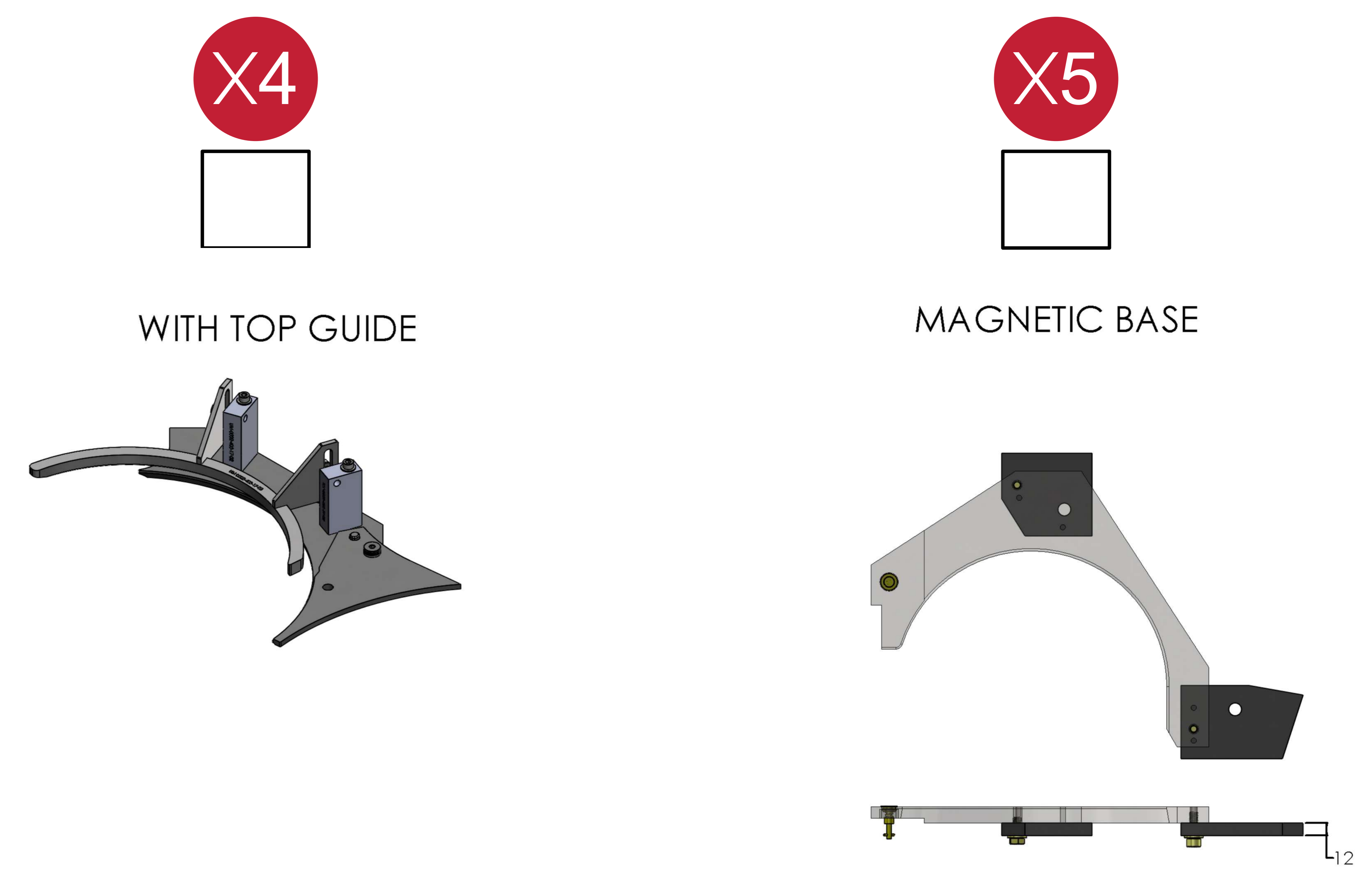

WITH TOP GUIDE

MAGNETIC BASE

TRI SECTOR

Form

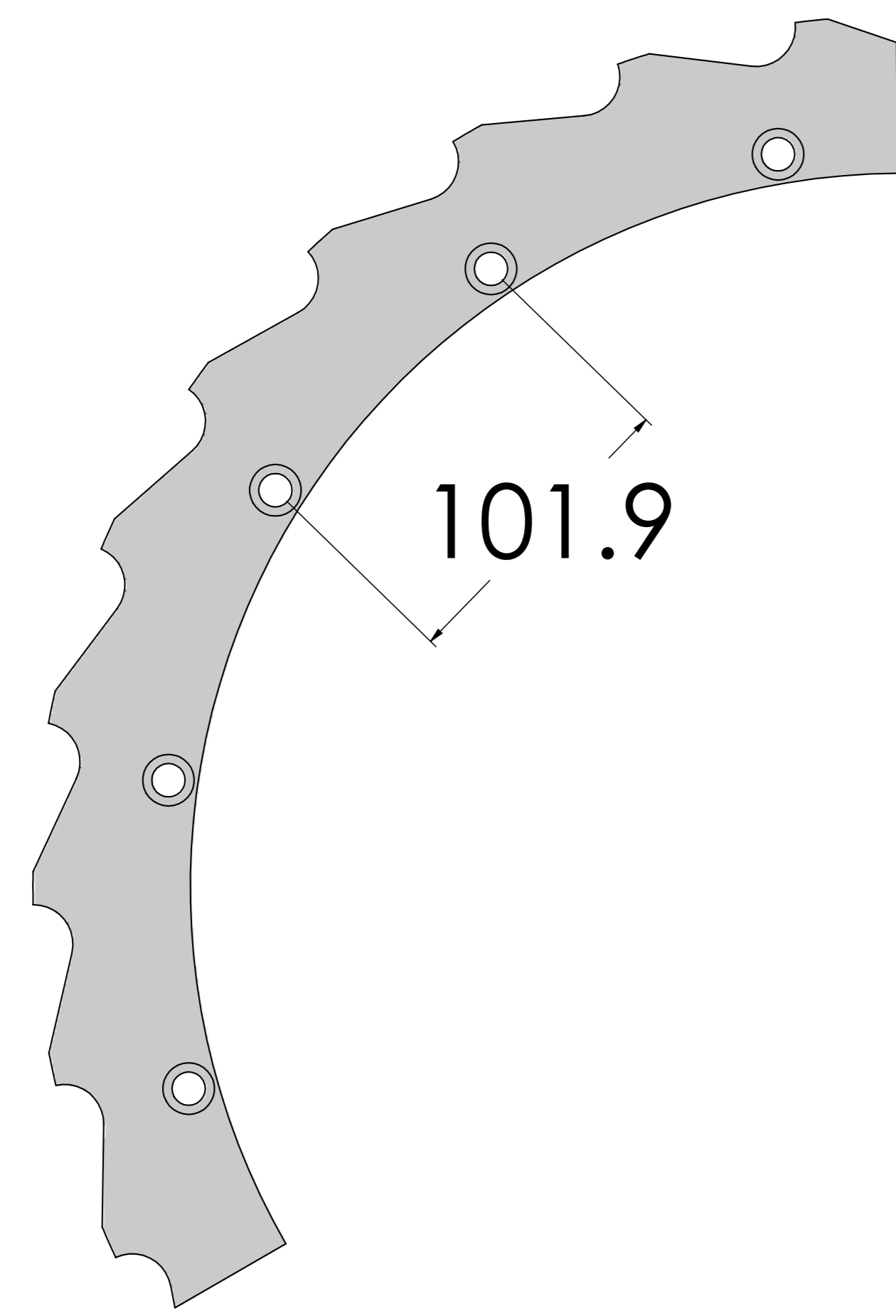
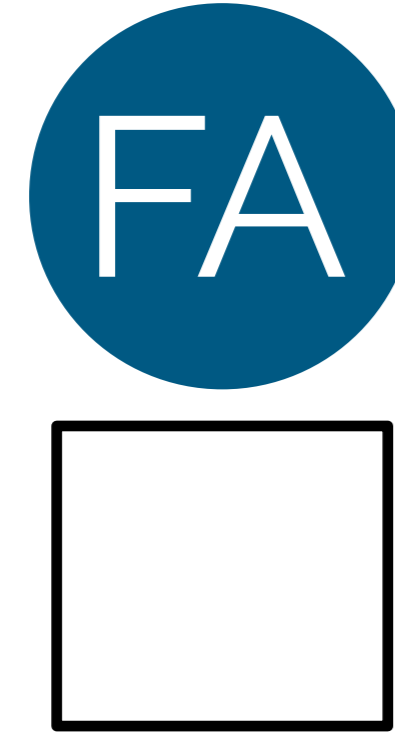

10 TEETH
THICKNESS : 11 mm
S1

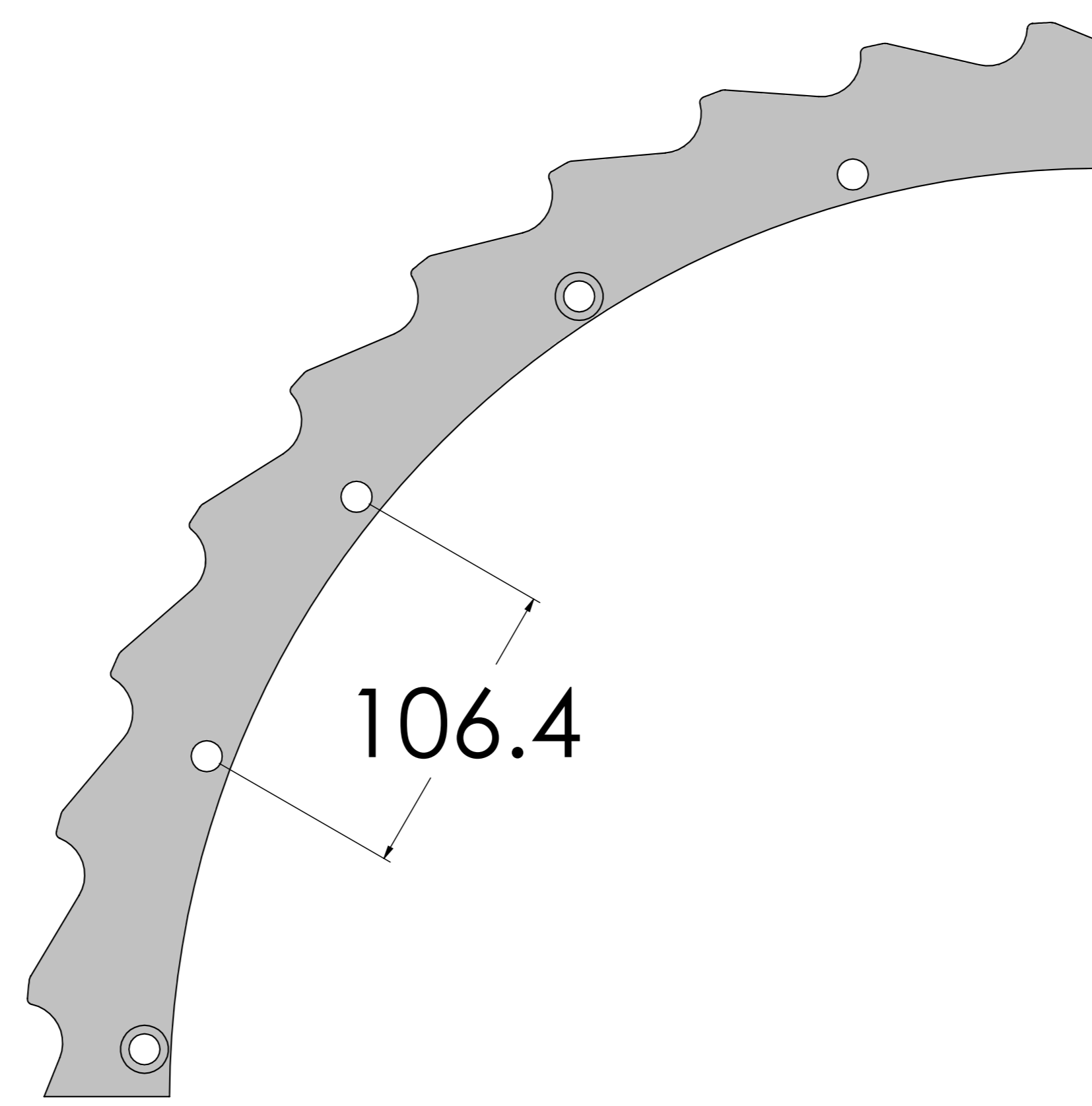
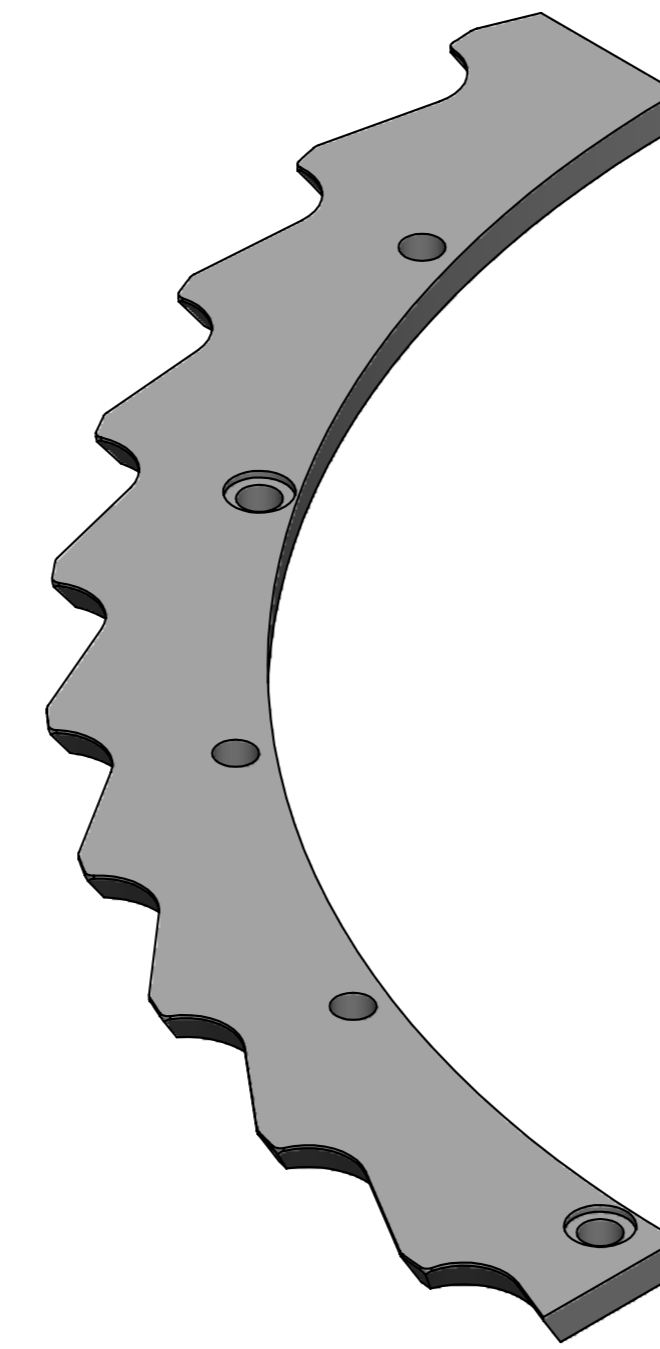
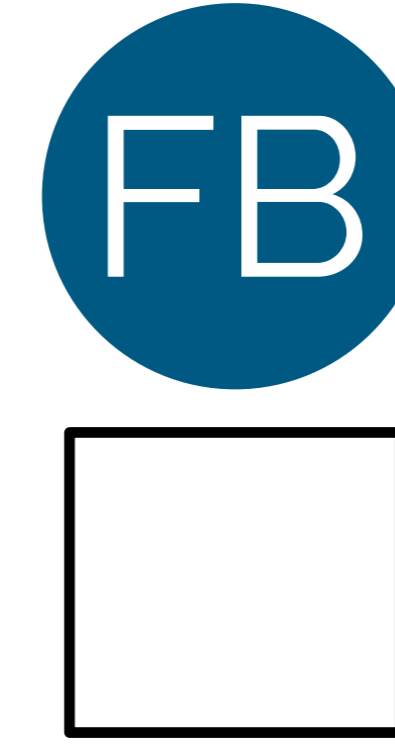

10 TEETH
THICKNESS : 11 mm
QUAD SECTOR
S1

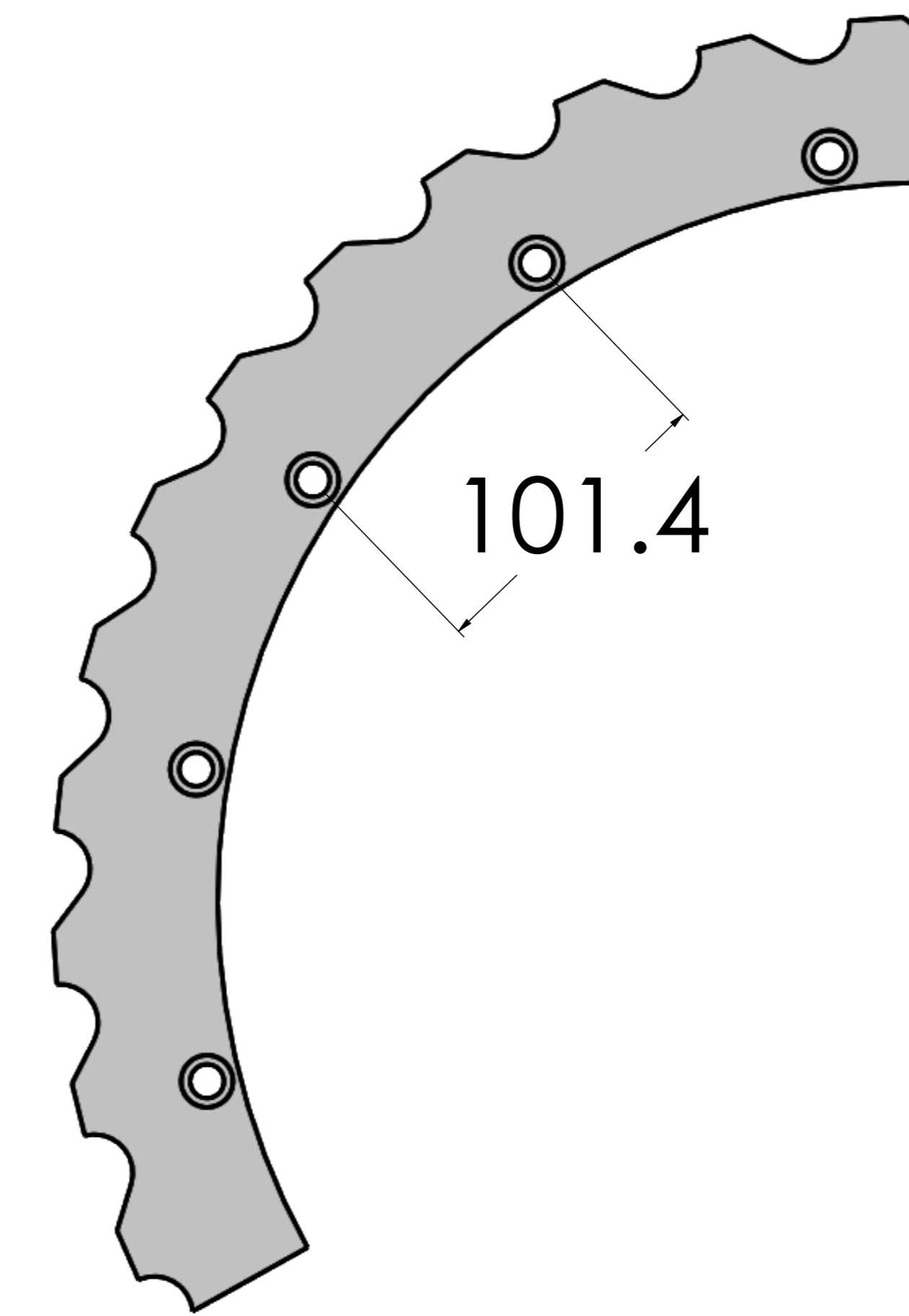



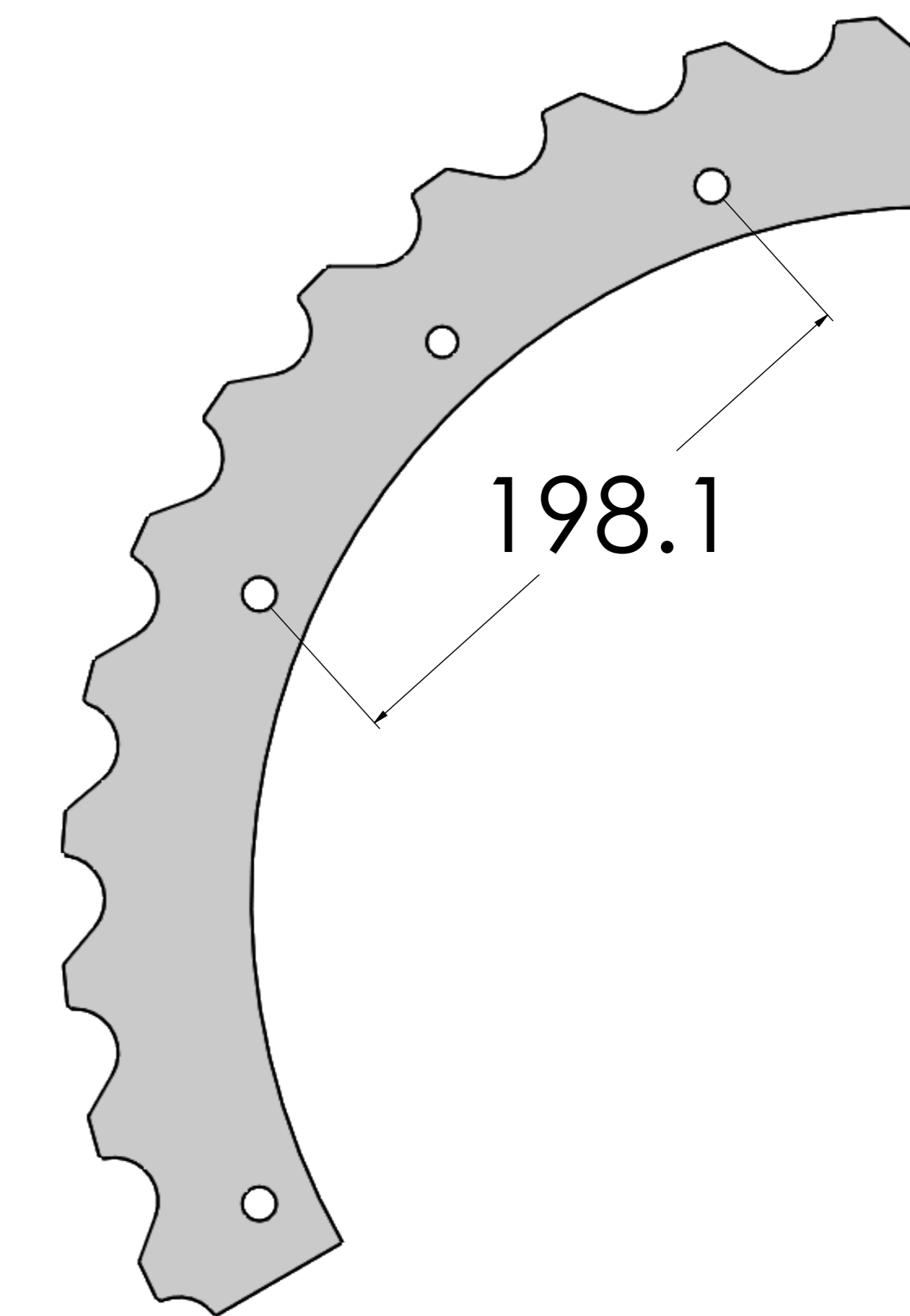
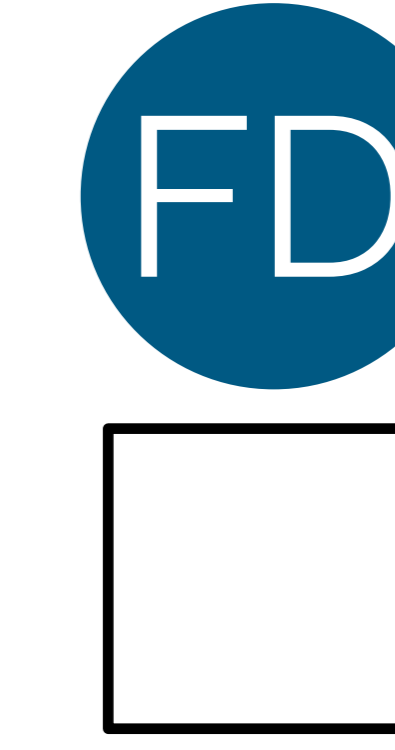



12 TEETH
THICKNESS : 10 mm
S2



12 TEETH
THICKNESS : 10 mm
UNIVERSAL

OVEN

 Ejector	9
 Guide & turnover cam	10
 Lamp	11
 Oven chain S1,S2 & Universal	12
 Oven exit guide	18
 Spindle tip	19

EJECTOR

Form

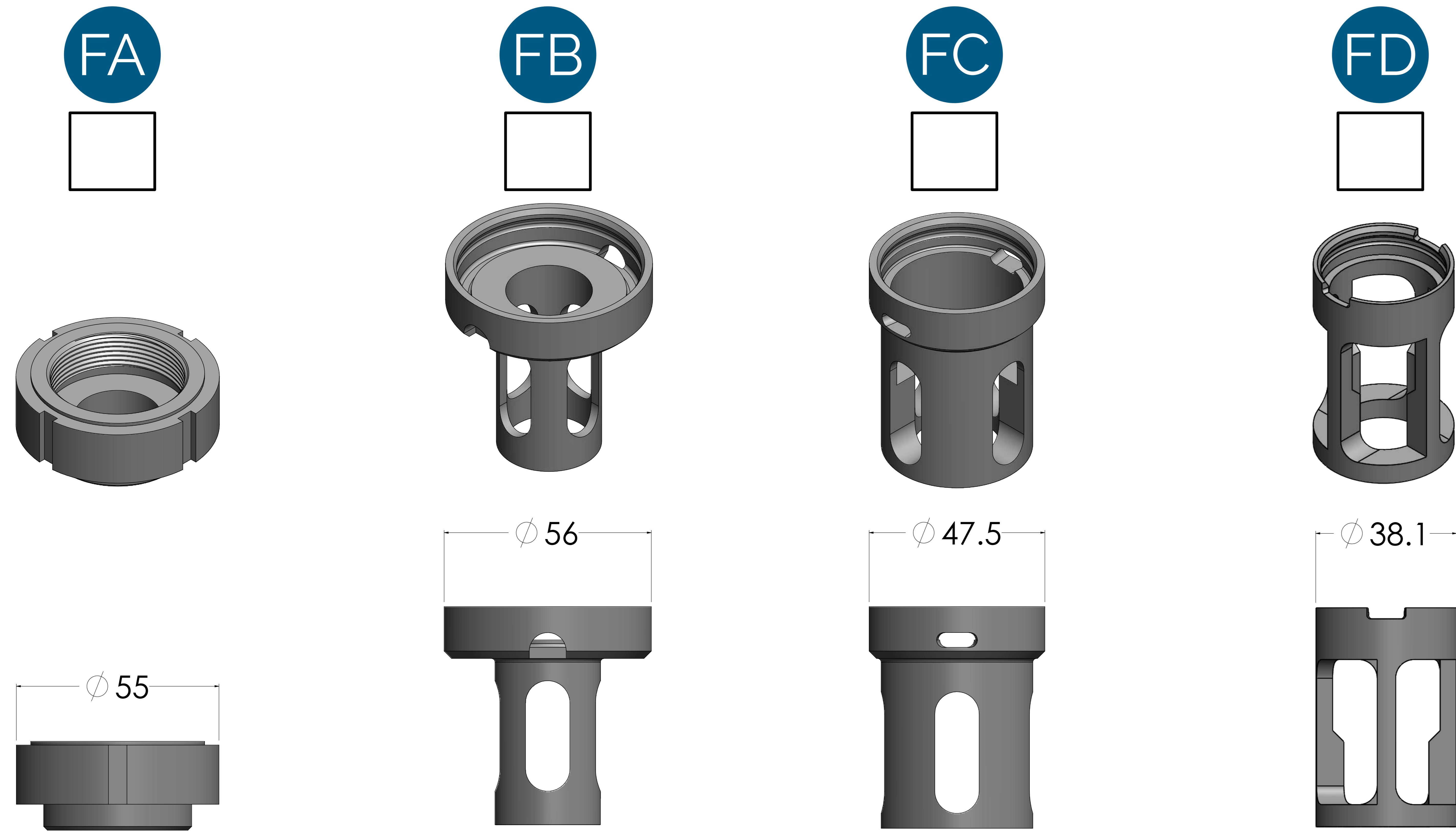

Option

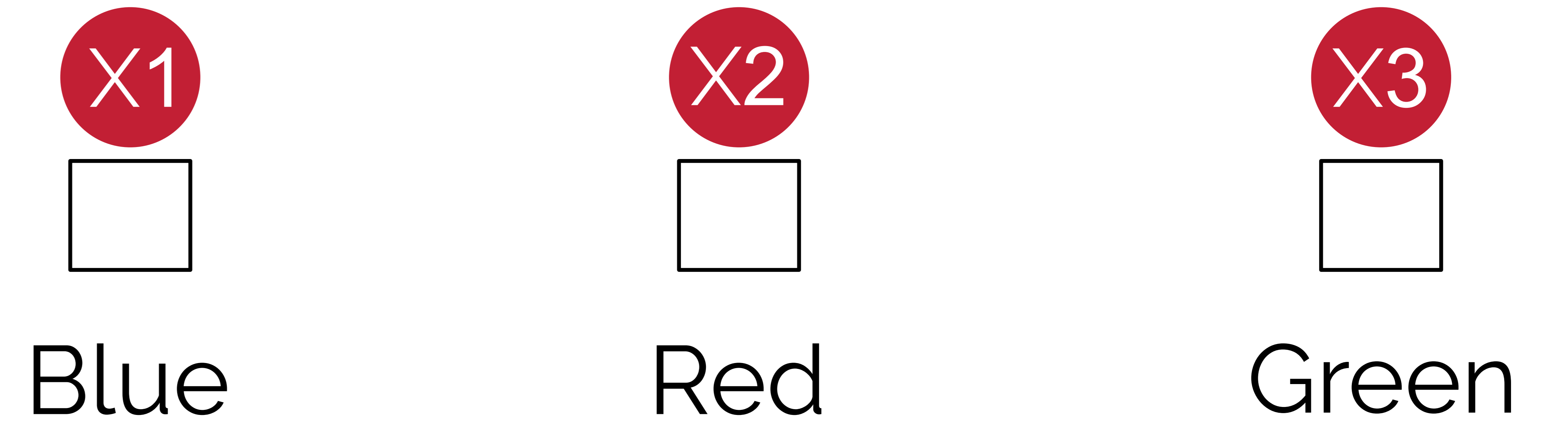

Specification

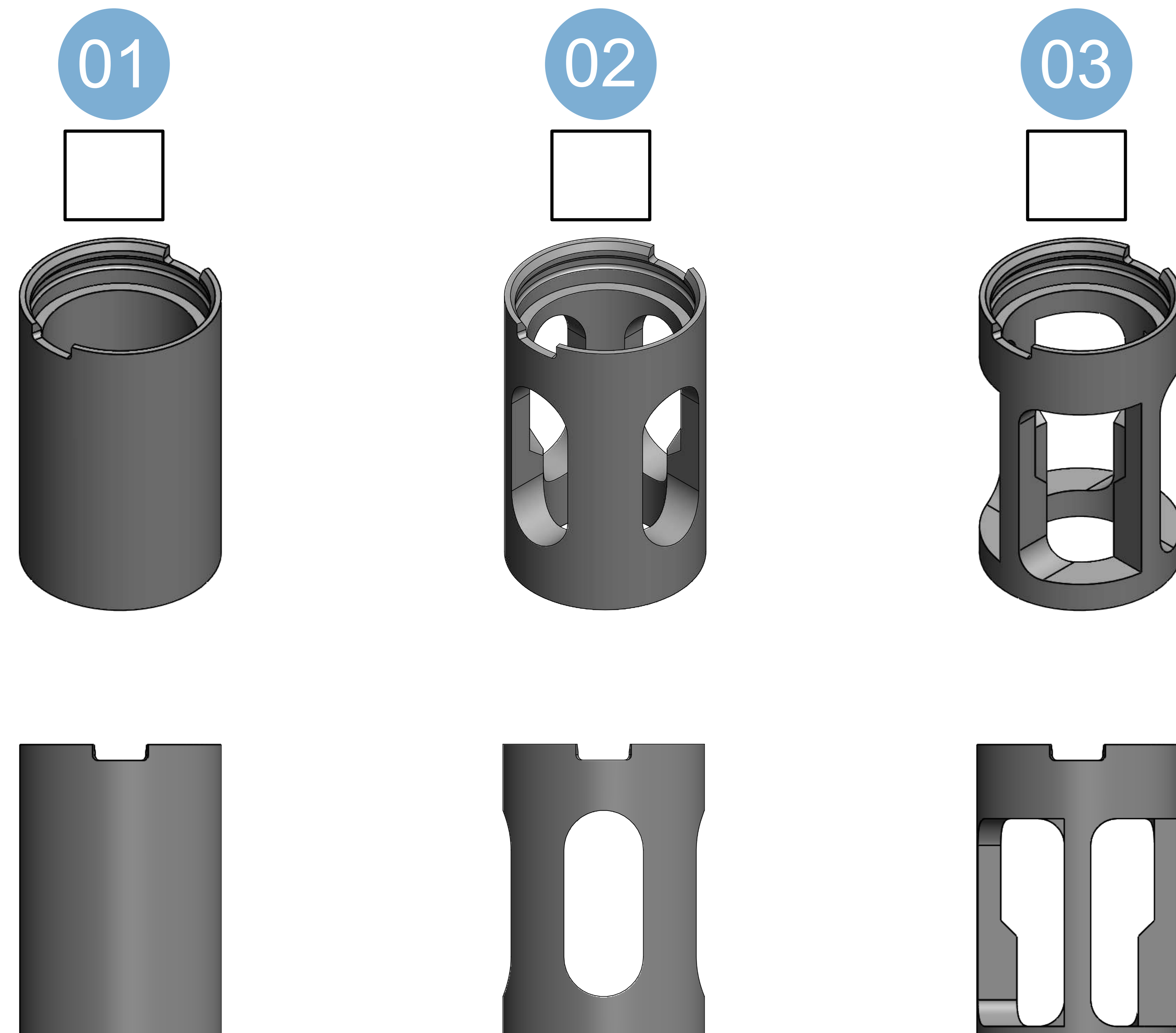

UM part #

NECK	EJECTOR
1881	UMS-EJ-1881-FF-SS
1810	UMS-EJ-1810-FF-SS
29/21	UMS-EJ-2921-FF-SS
29/25	UMS-EJ-2925-FF-SS
30/25	UMS-EJ-3025-FF-SS
38	UMS-EJ-3800-FF-SS

GUIDE & TURNOVER CAM



UMS-01071955601

UMS-01071955701

UM #	Description	Known OEM number
UMS-01071955601	S2 turn over cam	01071955601
UMS-01071955701	S2 turn over cam	01071955701

LAMP



Benefits

High efficiency: reduced running cost

Life 5000+ hours: reduced replacement cost

Most energy-efficient reflector coating

Compatible with all machine models

Clear or ceramic coated

Clear lamps compatible with external reflectors

2000W – 3000W

UM #	Description	Known OEM number
LAMP2352000280BH2	Oven lamp 2000W, 235V, 280 mm	00000038358
LAMP4002500315BH	Oven lamp 2500W, 400V, 315 mm	00000159385/00000035741
LAMP4003000315BH	Oven lamp 3000W, 400V, 315 mm	00000159384/00000035746

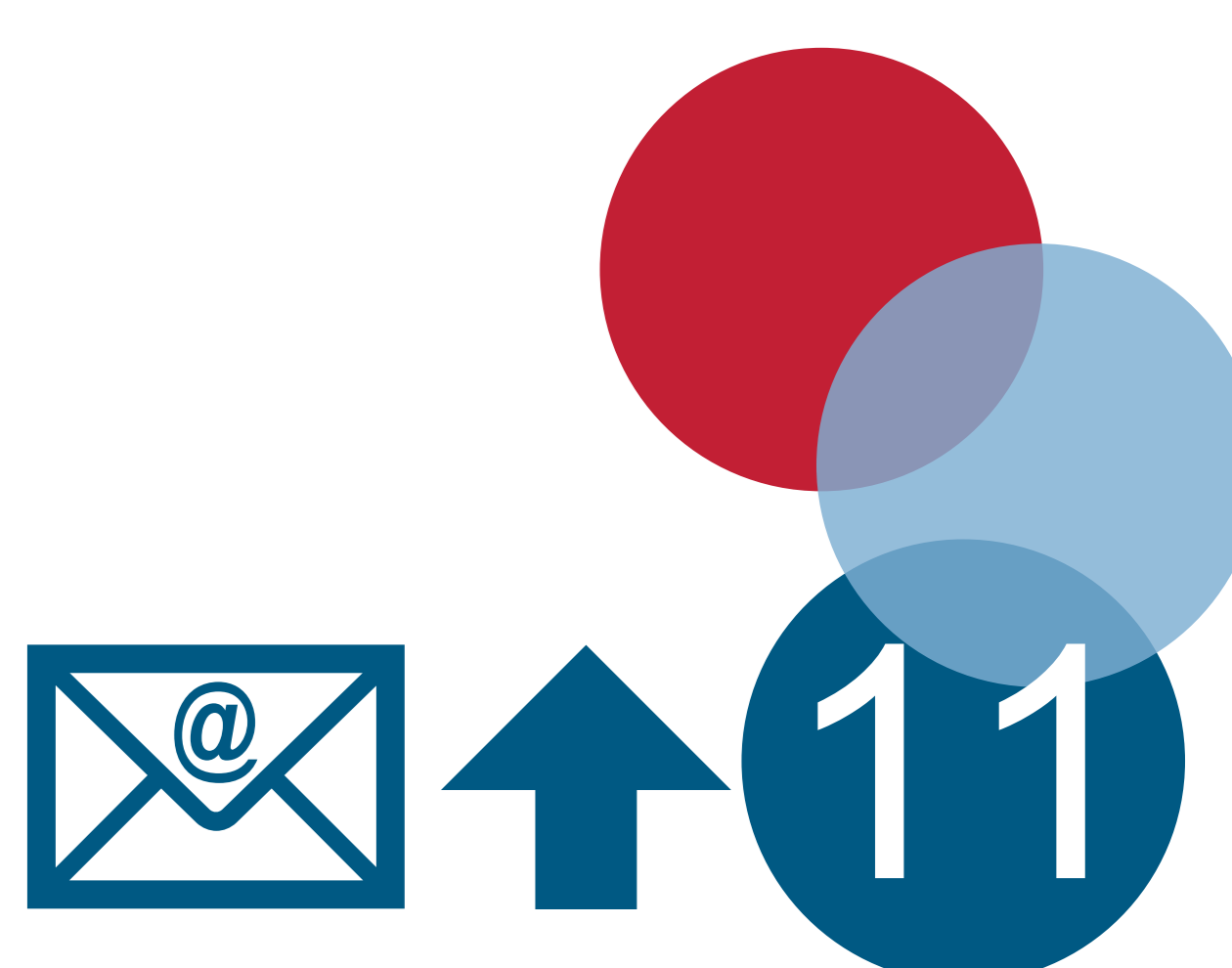

OVEN CHAIN S1



Benefits

OEM equivalent, high quality

Fully inspected unit and pitch

Plug and play unit

All combinations are available with personalized rebuilt kits

Fully compatible with OEM components

UM #	Description	Known OEM number
UMS-OC-S1-QC	Oven chain link S1 quick change	01066604206 01112088101 01965639109 01963833800 01065579501 01065639101 01071973101
UMS-OC-S1-NQC	Oven chain link S1 non-quick change	01964535602 01961621400 01962402600 01962704100 01962918200 01963445000

Rebuilt parts



Rebuilt parts oven chain
UMS-OVENCHAIN-S1-QC-KR

Standard components



Shaft
0002-401-20-43



Cylinder
UMS-01061621700



Axe roller
UMS-00000000563M



Axial ball joint
UMS-01064499500



Sprocket
UMS-01065579700M

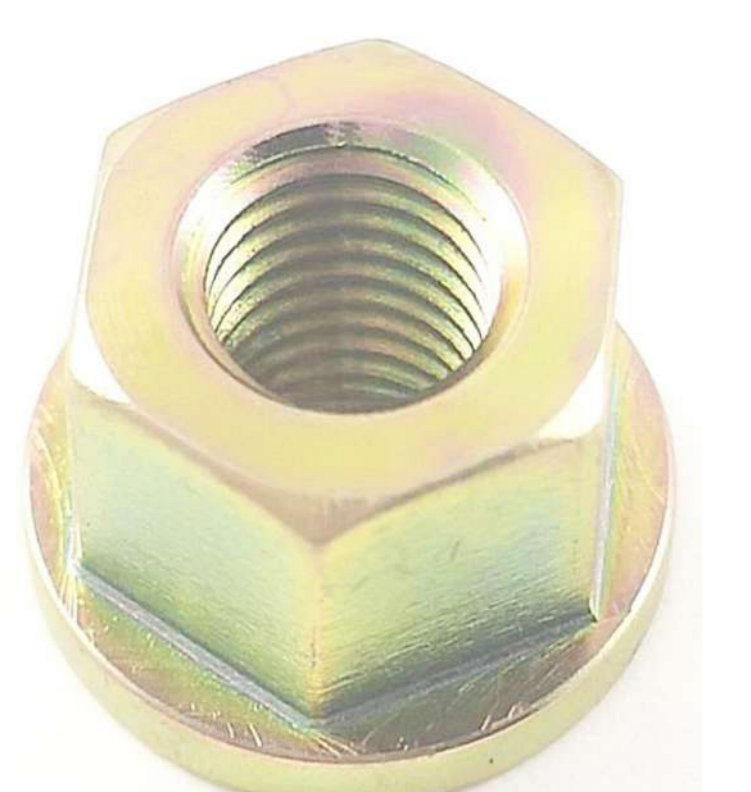

Collar nut
UMS-01074608002



Body oven chain
UMS-01062077000



Axe roller
UMS-00000000564M

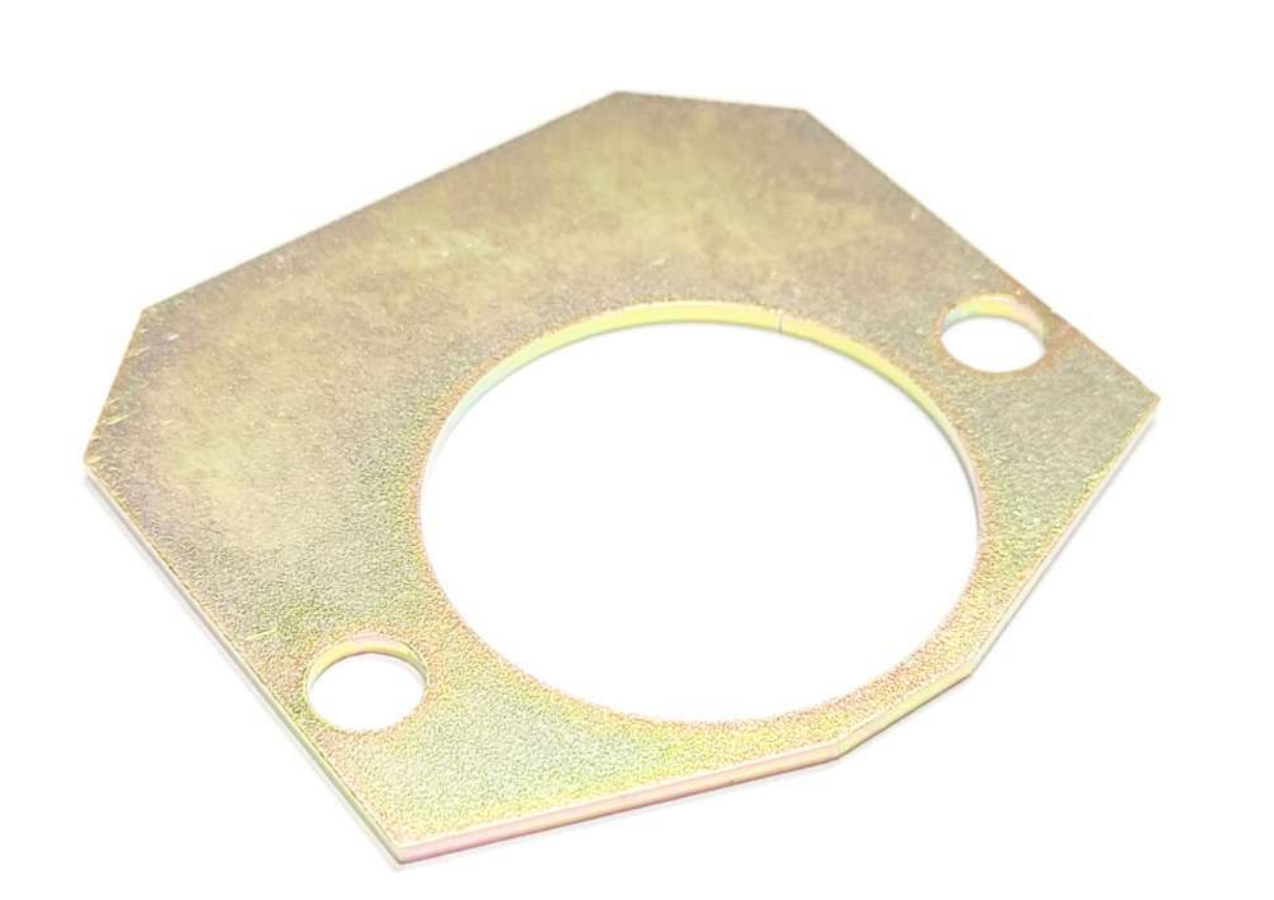

Oven chain cover
UMS-01061622100

IMPROVED OVEN CHAIN S1

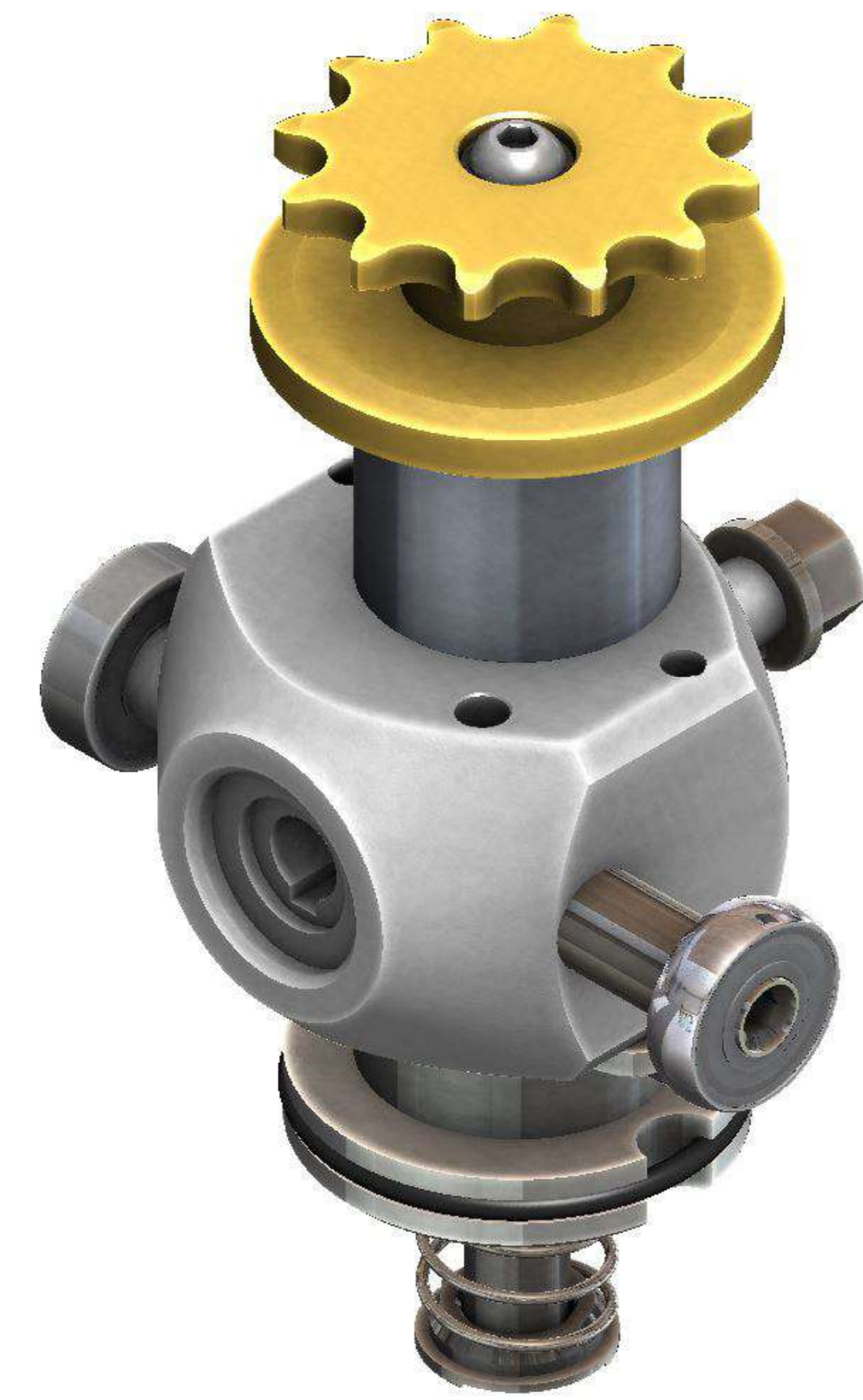

Upgraded S1 chain QC



Upgraded S1 chain NQC



Improved link
UMS-01062077000M

Rebuilt parts

Rebuilt parts
UMS-OC-S1-NQC-MKR

Rebuilt parts
UMS-OC-S1-QC-MKR

Conversion kit

QC conversion kit
0002-401-20-79

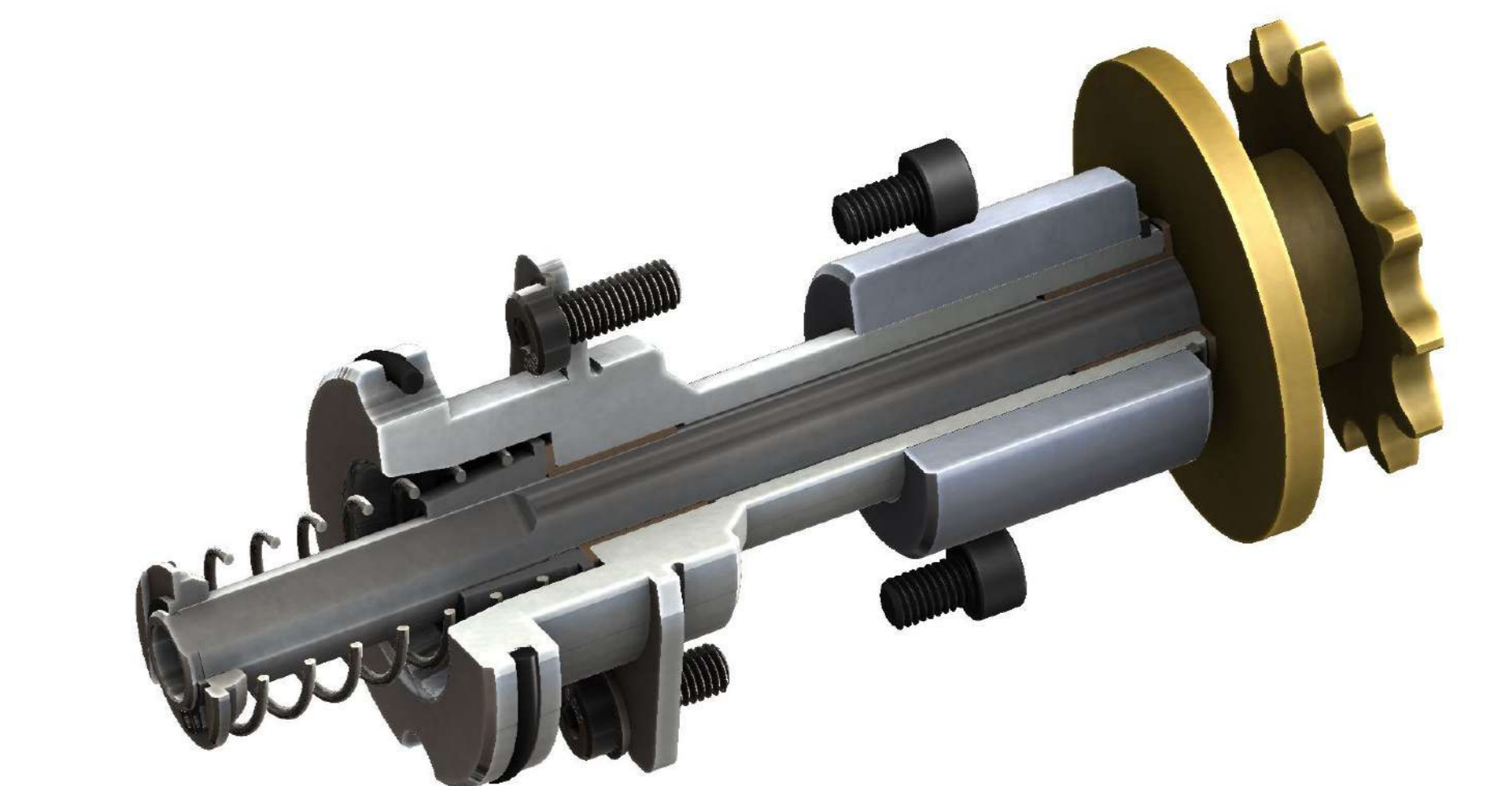

NQC conversion kit
0002-401-20-78

Benefits

Plug & play unit

Lighter (453g per link)

Repairable link

Elimination of alignment problems between upper and lower body

Uses universal NQC spindle tip

Uses self-lubricating bearings instead of oilite

UM #	Description	Known OEM number
UMS-OC-S1-QC-M	Improved oven chain link S1 QC	01066604206 01066135208
UMS-OC-S1-NQC-M	Improved oven chain link S1 NQC	01063445000

OVEN CHAIN S2



Benefits

- OEM equivalent, high quality
- Fully inspected unit and pitch
- Plug and play unit
- All combinations are available with personalized rebuilt kits
- Fully compatible with OEM components

UM #	Description	Known OEM number
UMS-OC-S2-QC	Oven chain link S2 quick change (pitch 50 mm)	01111316401 to 06, 01111316501 to 03, 01111316601 to 03, 01072508001 to 12
UMS-OC-S2-NQC	Oven chain link S2 none quick change	01118338601 to 03 01118342701 to 06
UMS-OC-S2-QC-V	Oven chain link S2 quick change, « V » track roller/guided spindle pitch (pitch 50 mm)	01143730301
UMS-OC-S2-NQC-V	Oven chain link S2 none quick change, « V » track roller/guided spindle pitch (pitch 50 mm)	

Rebuilt parts



Standard components



 Pinion



Chain assembly with rivet
UMS-01135661503

OVEN CHAIN S2

Rebuilt parts & Standard components



UM #	Description	Known OEM number	UM #	Description	Known OEM number
UMS-99000031524	Rebuilt kit	99000031524	UMS-01139999402M	Lower pinion	01139999401 to 02
UMS-99000438017	Rebuilt kit	99000438017	UMS-01139999302M	Upper pinion	01139999301 to 02
UMS-99000437791	Rebuilt kit	99000437791	UMS-01118342901M	Lower pinion quick change	01118342901, 01111316201, 01142455501 to 02
UMS-OC-S2-KR	Rebuilt kit		UMS-01118342801M	Upper pinion quick change	01118342801, 01111316301, 01142455601 to 02
UMS-OC-S2-KR2	Rebuilt kit		UMS-01135991901M	Lower pinion quick change	01135991901
UMS-OC-S2-KR3	Rebuilt kit		UMS-01135992101M	Upper pinion quick change	01135992101
			UMS-01126903803M	Lower pinion none quick change	01126903801 to 03
			UMS-01126903903M	Upper pinion none quick change	01126903901 to 03
			UMS-01136600805M	Lower pinion none quick change	01136600801 to 05
			UMS-01136600905M	Upper pinion none quick change	01136600901 to 05

OVEN CHAIN UNIVERSAL



Benefits

OEM equivalent, high quality

Fully inspected unit and pitch

Plug and play unit

All combinations are available with personalized rebuilt kits

Fully compatible with OEM components

UM #	Description	Known OEM number
UMS-OC-UN-QC	Quick change Pitch 50 mm	01125560801 to 15
UMS-OC-UN-QC-V	Quick change with « V » track roller/guided spindle pitch Pitch 50 mm Pitch 50 mm	01129524501 to 08 01136624801 to 06
UMS-OC-UN-NQC	None quick change Pitch 50 mm	01125579301 to 10
UMS-OC-UN-NQC-V	None quick change with « V » track roller/guided spindle pitch Pitch 50 mm Pitch 50 mm	01129877201 to 06 01129876707 to 09
UMS-OC-UN-QC-P40	Quick change Pitch 40 mm	01125550301 to 10
UMS-OC-UN-QC-P40-V	Quick change with « V » track roller/guided spindle pitch Pitch 40 mm	
UMS-OC-UN-NQC-P40	None quick change Pitch 40 mm	01125516401 to 13
UMS-OC-UN-NQC-P40-V	None quick change with « V » track roller/guided spindle pitch Pitch 40 mm Pitch 40 mm	01126747804 to 10 01126739211 to 14

Rebuilt parts 

Standard components



Oven chain rebuilt parts
UMS-OC-UN-P40-KR
UMS-OC-UN-P50-KR



Oven chain rebuilt parts
UMS-OC-UN-SP-KR



Oven chain rebuilt parts
UMS-OC-UN-P40-V-KR
UMS-OC-UN-P50-V-KR



Oven chain rebuilt parts
UMS-OC-UN-V-SP-KR



 Pinion

OVEN CHAIN UNIVERSAL

Rebuilt parts & Standard components



UM #	Description	Known OEM number	UM #	Description	Known OEM number
UMS-OC-UN-P50-KR	Rebuilt kit		UMS-01139999402M	Lower pinion	01139999401 to 02
UMS-OC-UN-P40-KR	Rebuilt kit		UMS-01139999302M	Upper pinion	01139999301 to 02
UMS-OC-UN-SP-KR	Rebuilt kit		UMS-01118342901M	Lower pinion quick change	01118342901, 01111316201, 01142455501 to 02
UMS-OC-UN-P50-V-KR	Rebuilt kit		UMS-01118342801M	Upper pinion quick change	01118342801, 01111316301, 01142455601 to 02
UMS-OC-UN-P40-V-KR	Rebuilt kit		UMS-01135991901M	Lower pinion quick change	01135991901
UMS-OC-UN-V-SP-KR	Rebuilt kit		UMS-01135992101M	Upper pinion quick change	01135992101
			UMS-01126903803M	Lower pinion none quick change	01126903801 to 03
			UMS-01126903903M	Upper pinon none quick change	01126903901 to 03
			UMS-01136600805M	Lower pinion none quick change	01136600801 to 05
			UMS-01136600905M	Upper pinion none quick change	01136600901 to 05

OVEN EXIT GUIDE

Form

FA

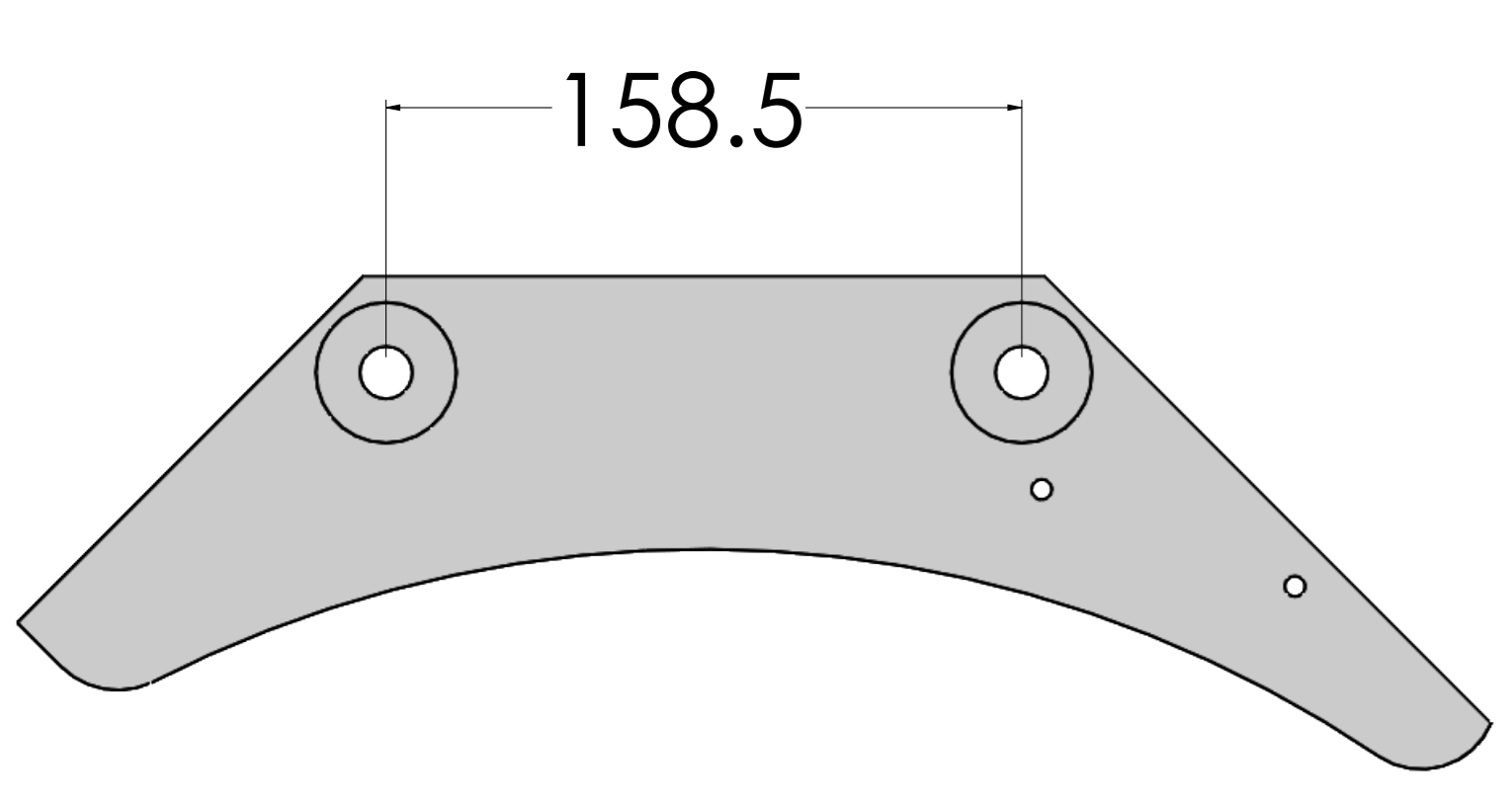
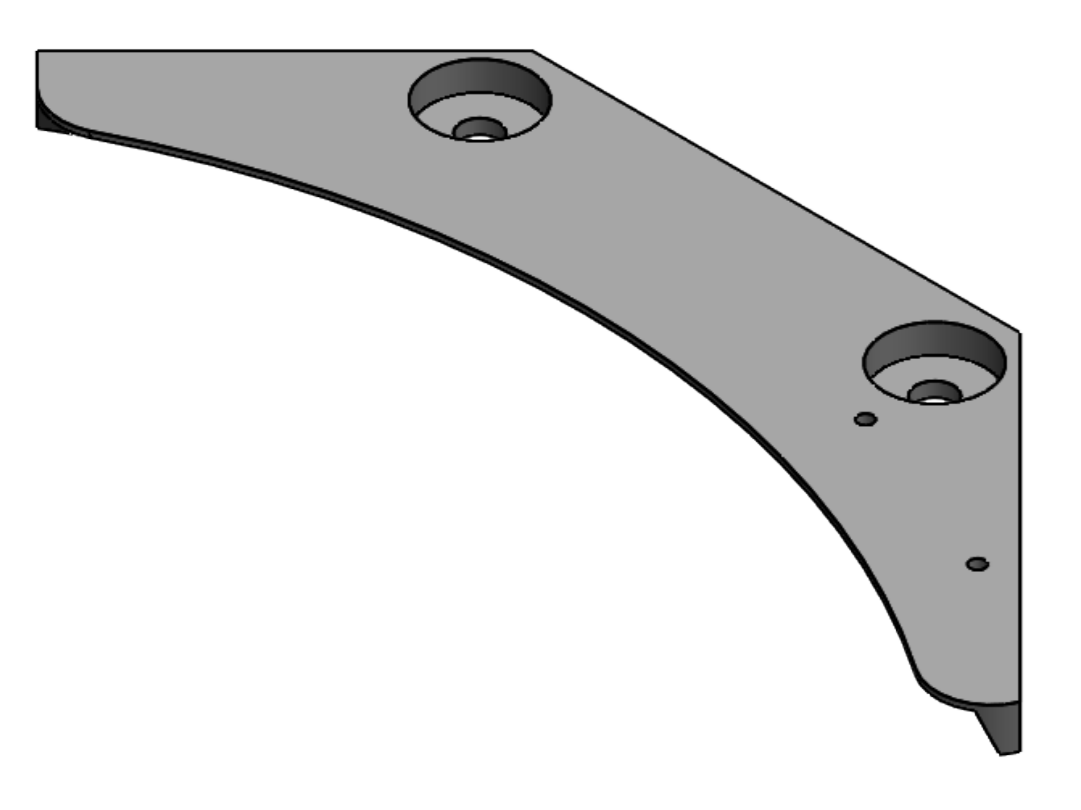
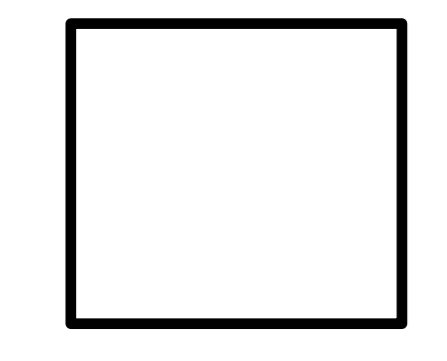

THICKNESS : 15 mm

FB

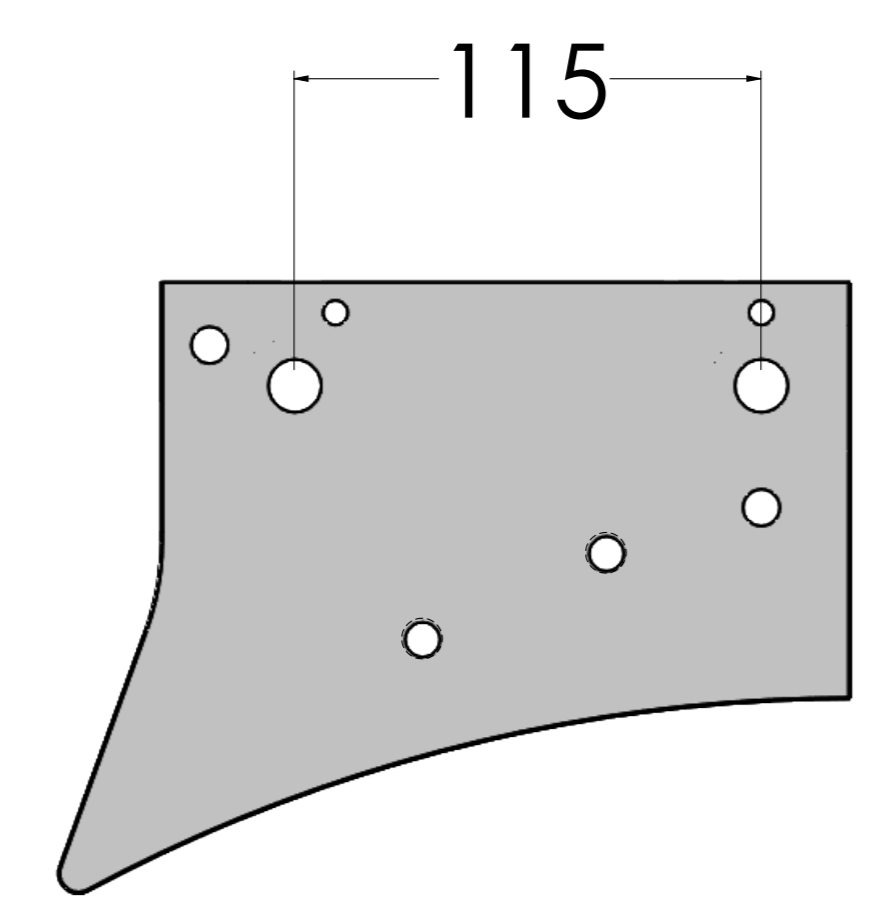
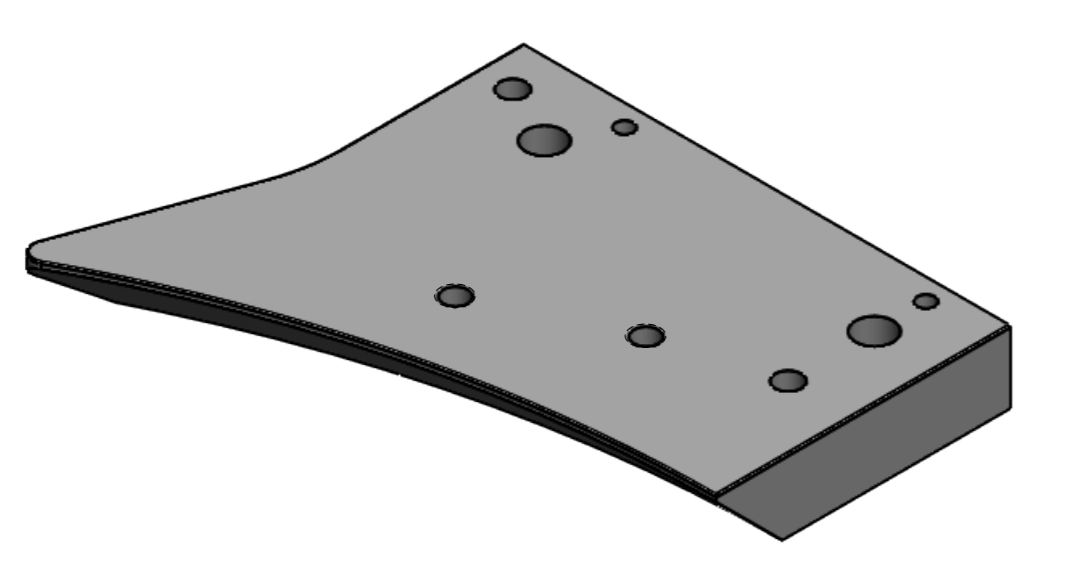
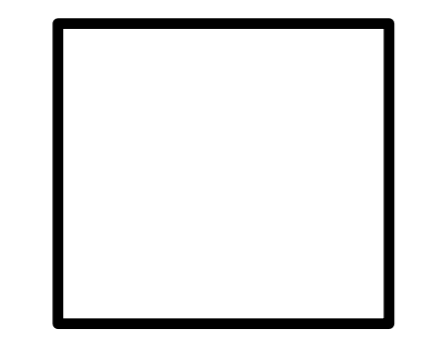

THICKNESS : 24.5 mm

FC

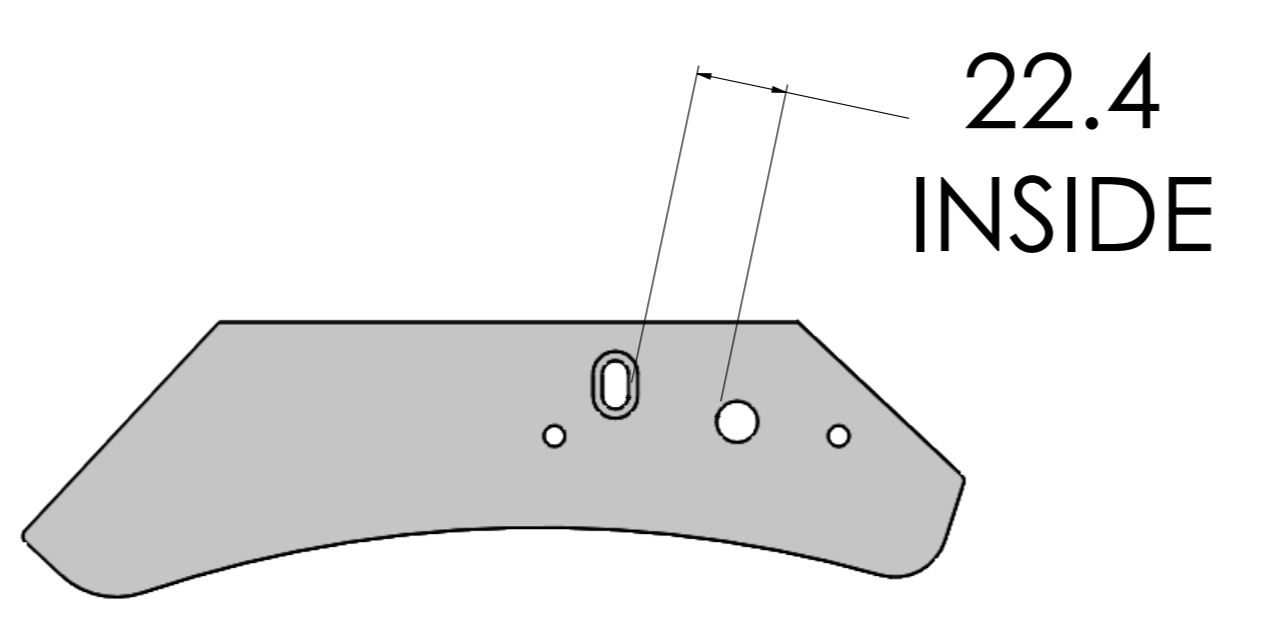
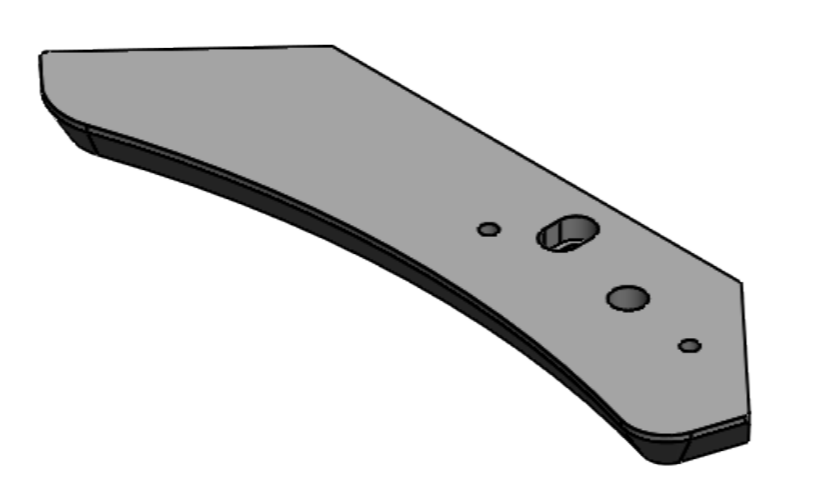
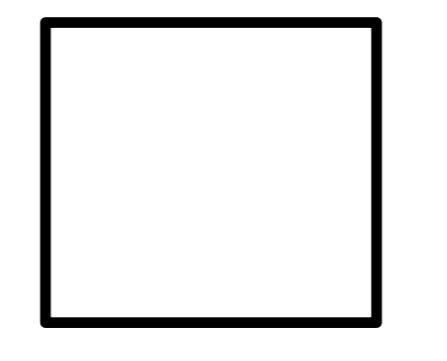

THICKNESS : 13 mm

X1

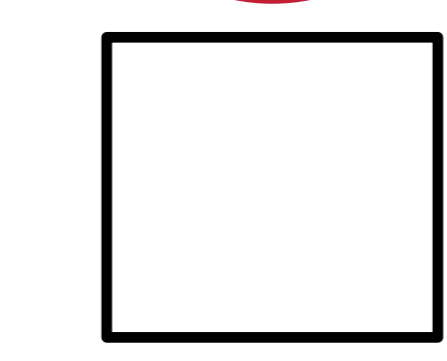

MAGNETIC BASE

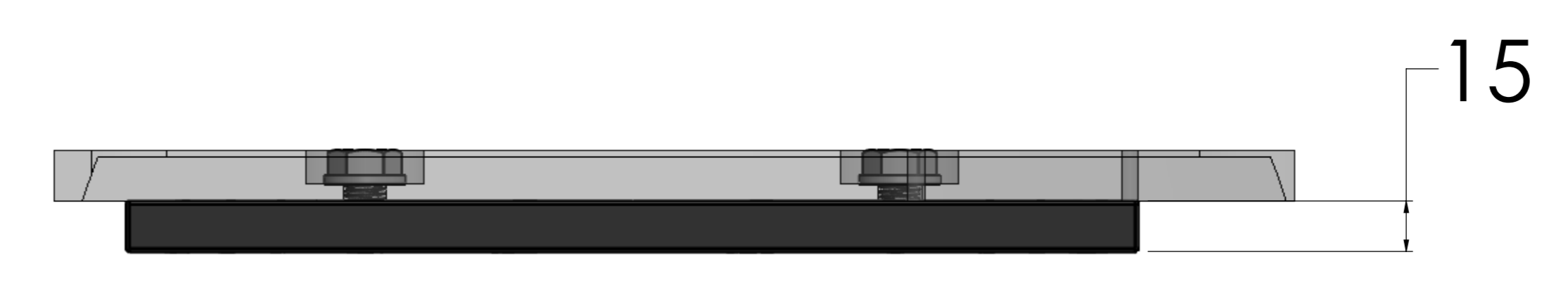
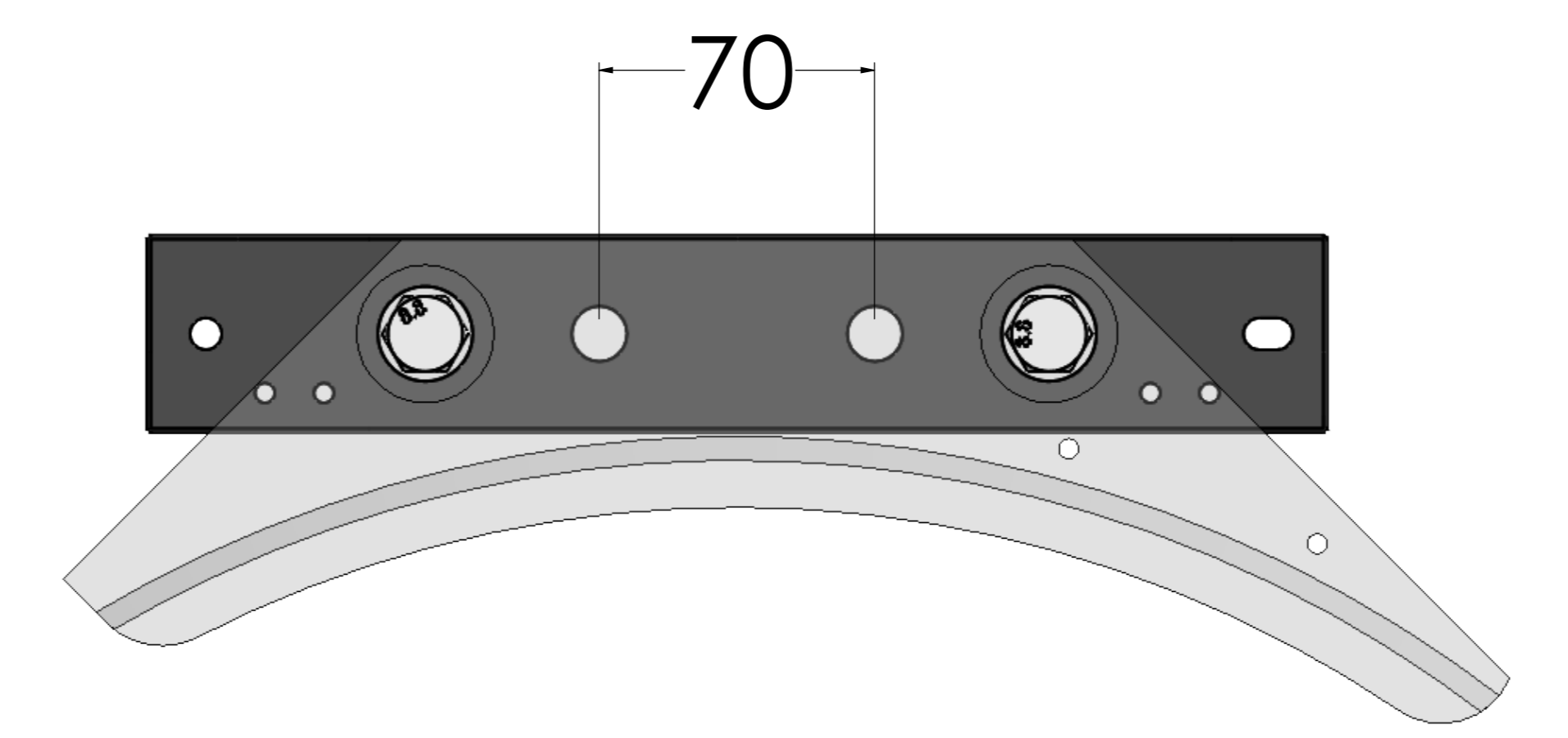

X2

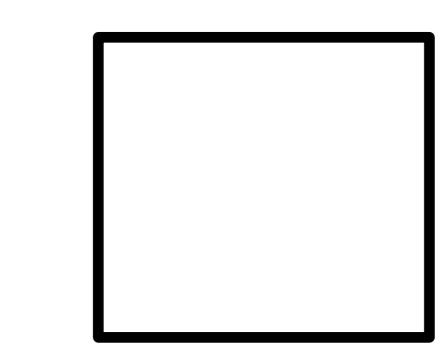

MAGNETIC BASE

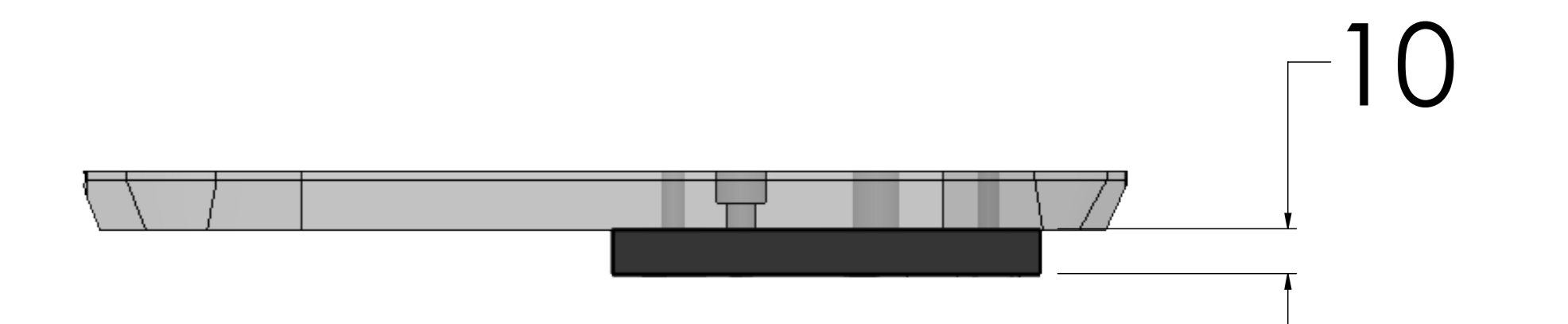
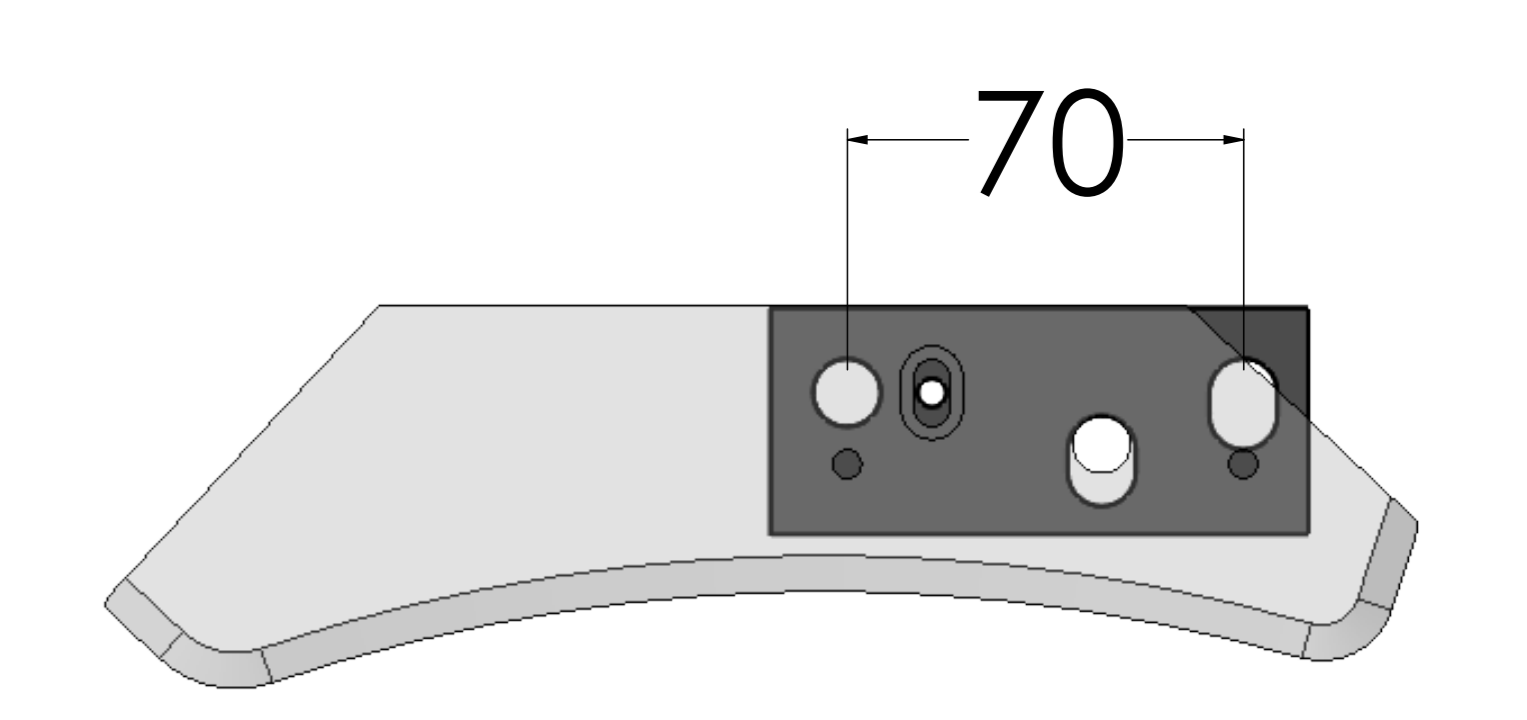

Option

FD

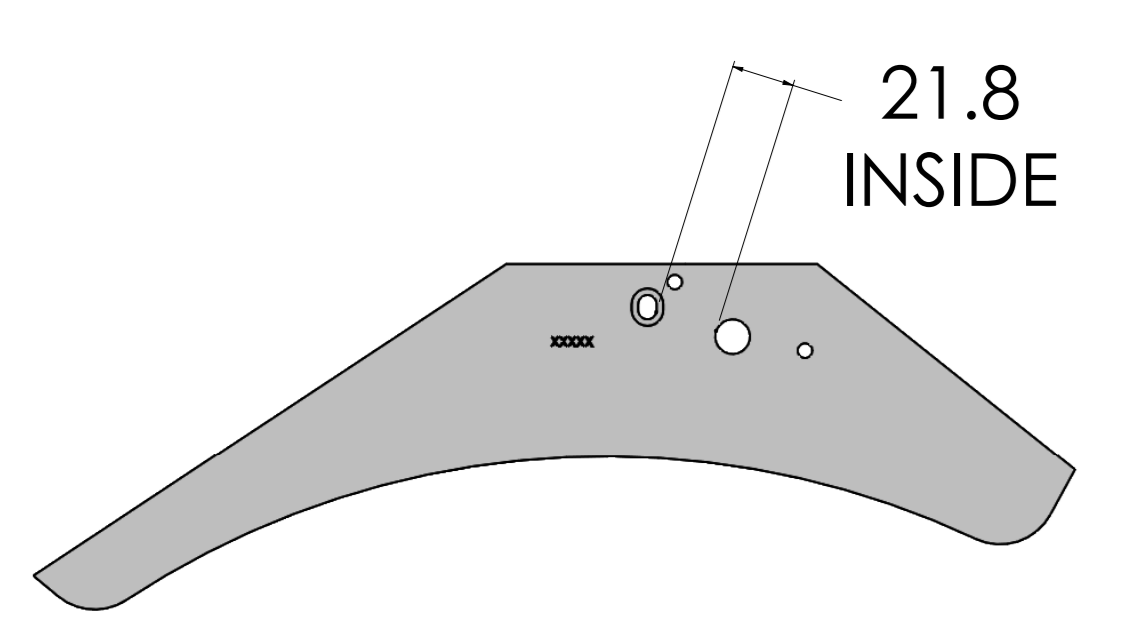
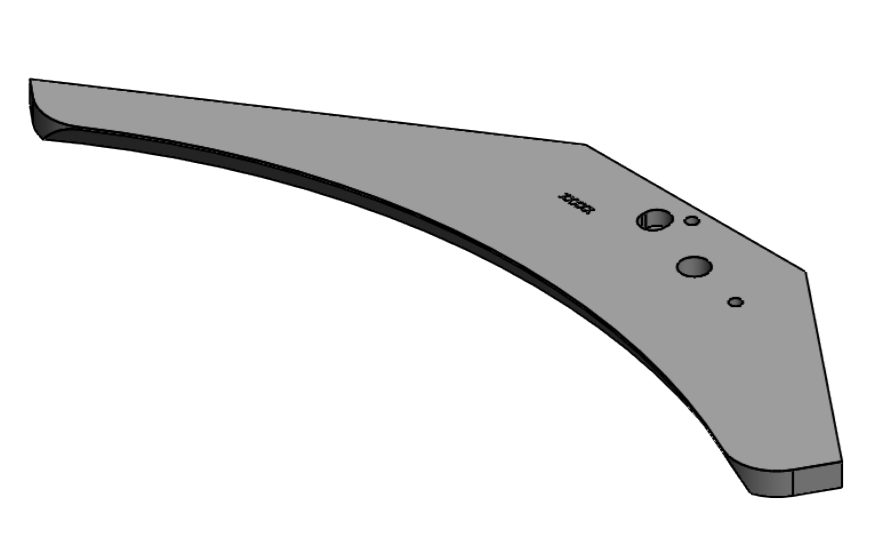
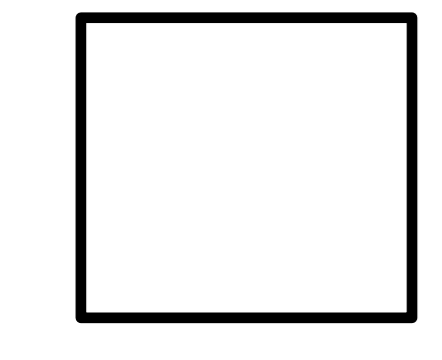

THICKNESS : 11 mm

FE

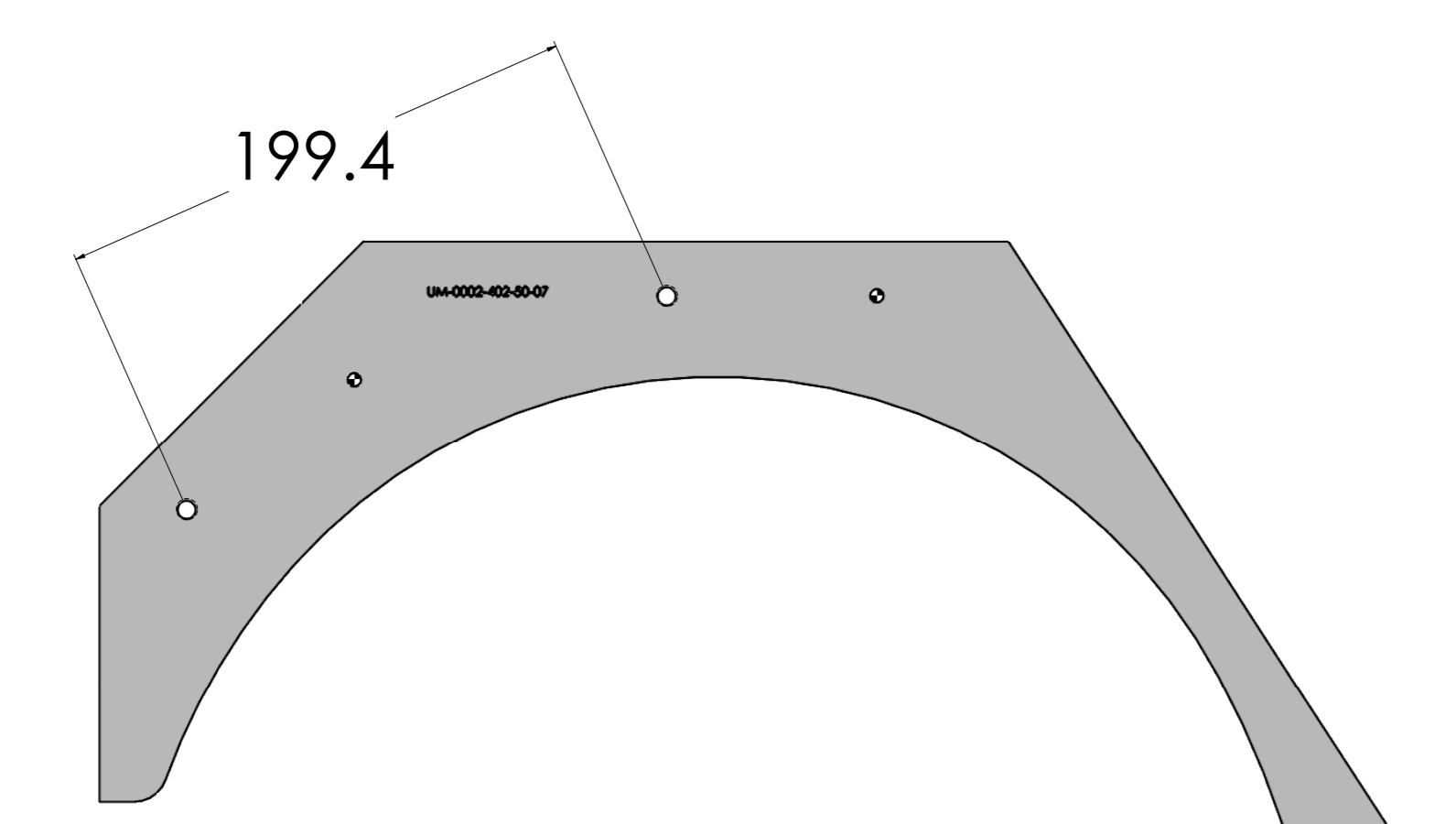
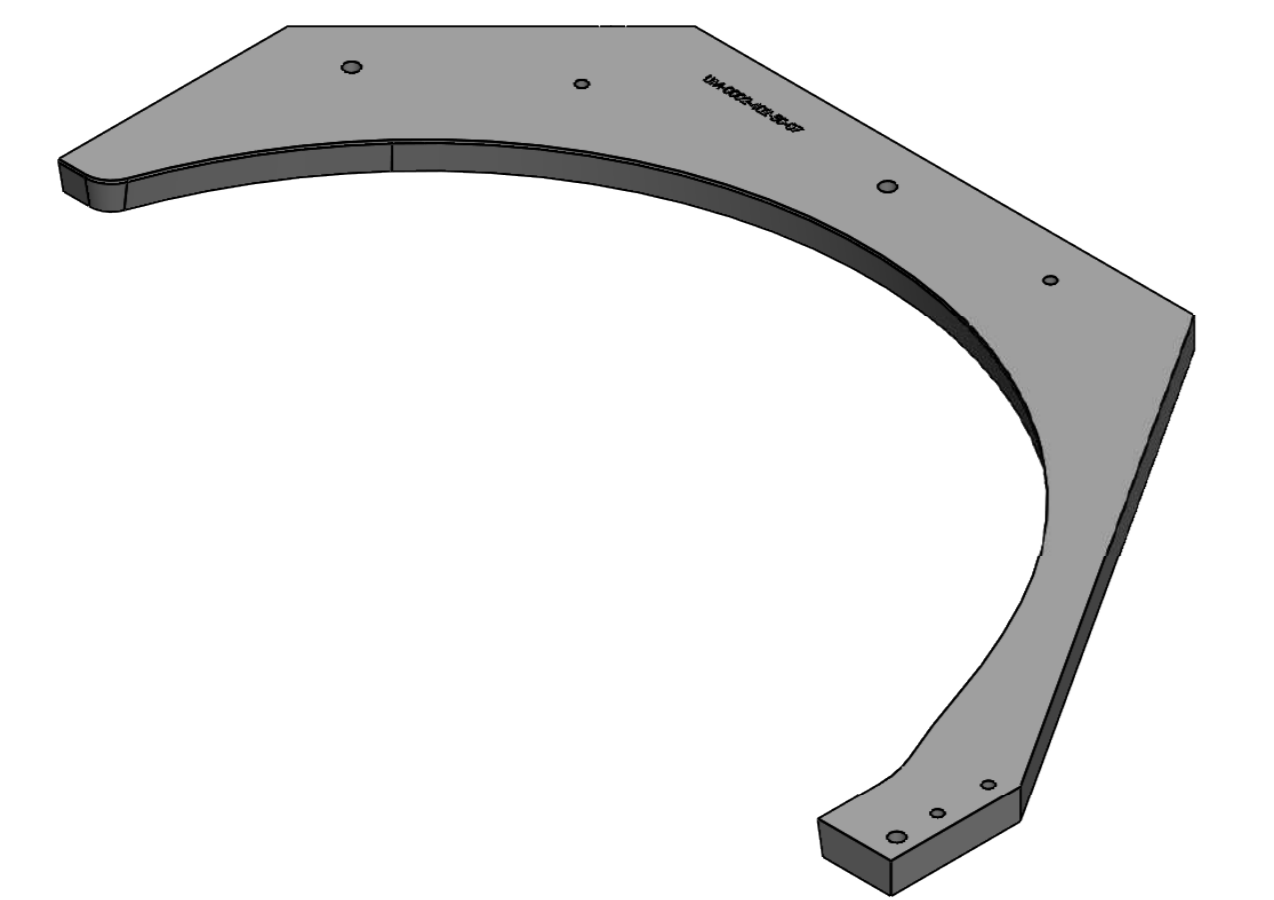
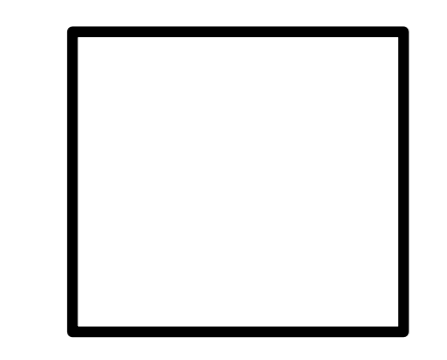

THICKNESS : 15 mm

FF

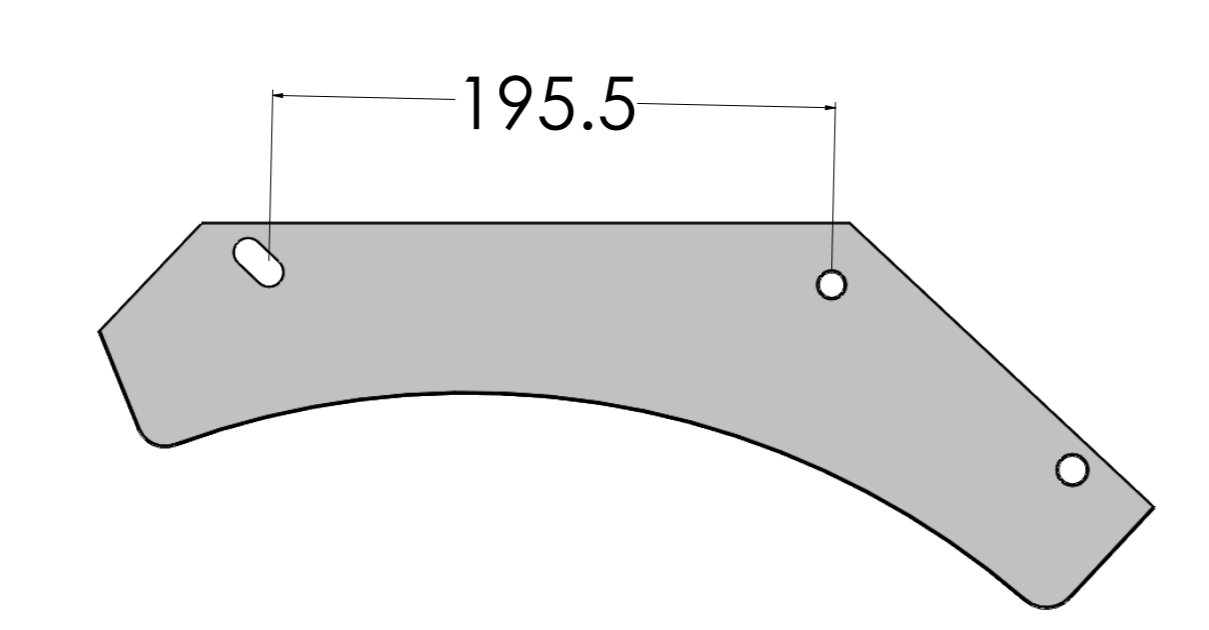
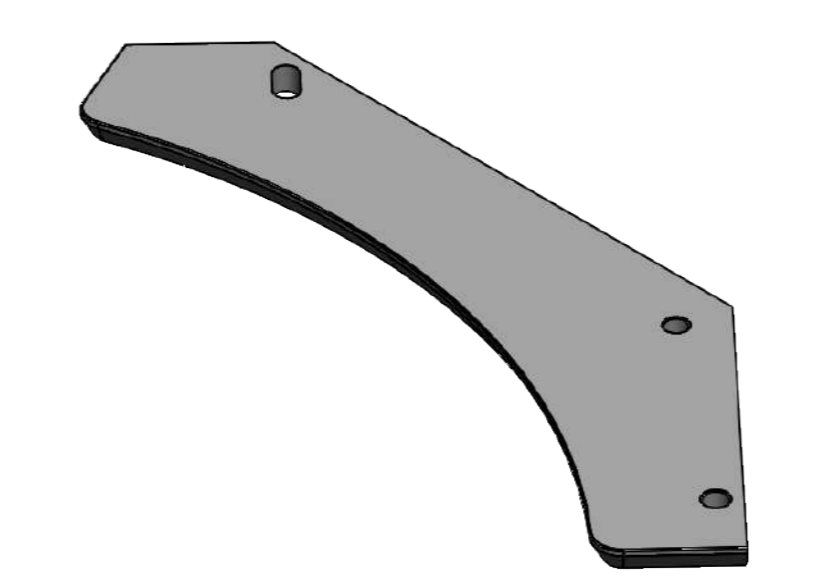
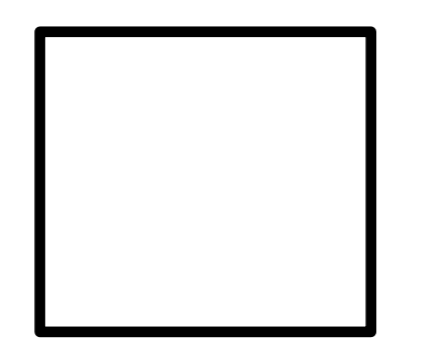

THICKNESS : 11 mm

FG

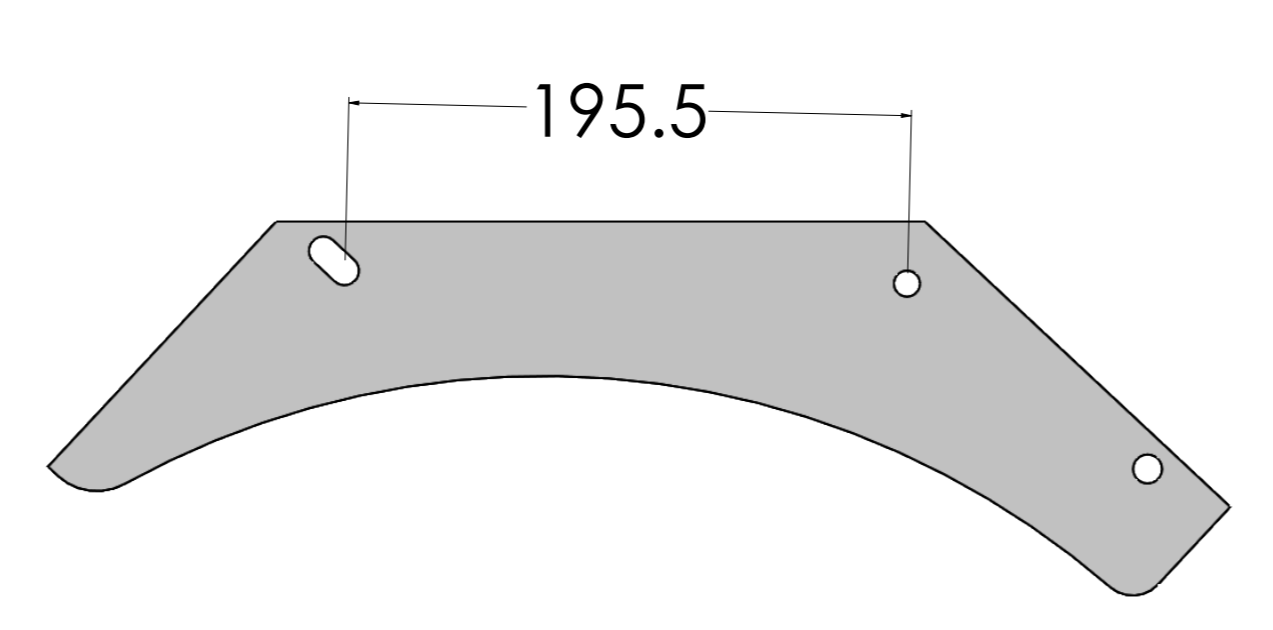
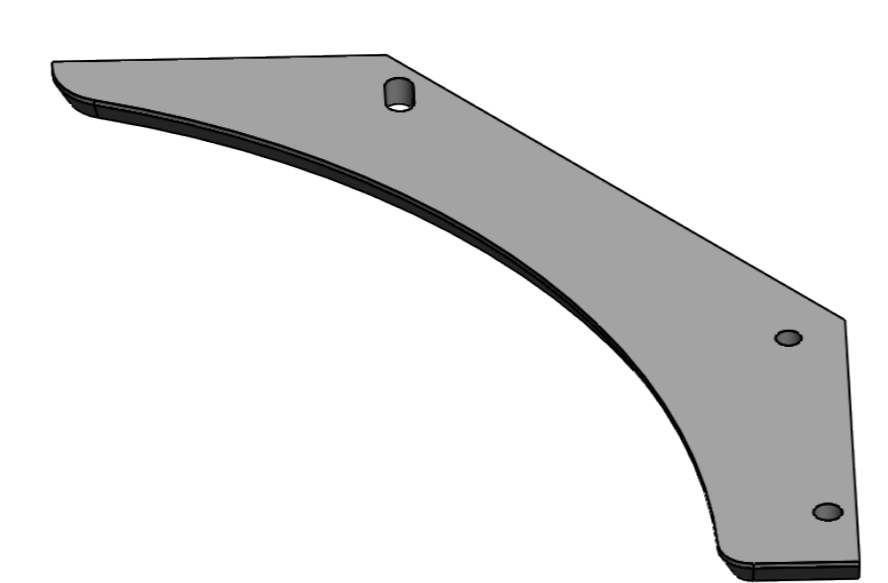
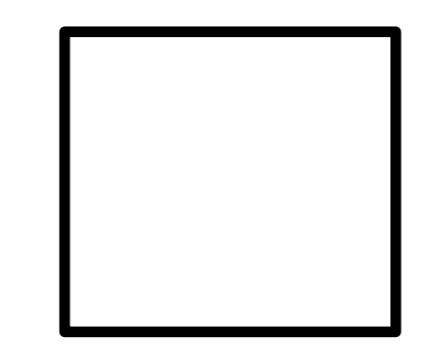

THICKNESS : 11 mm

X3

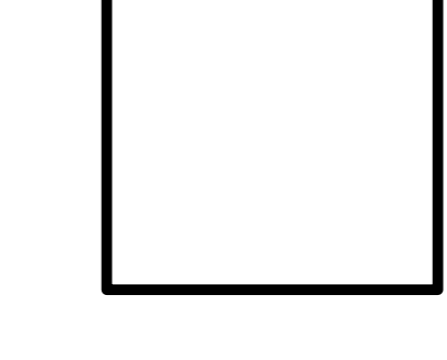

MAGNETIC BASE

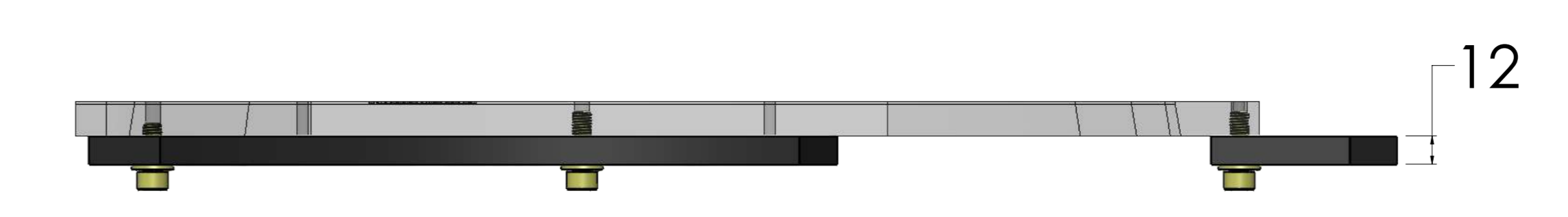
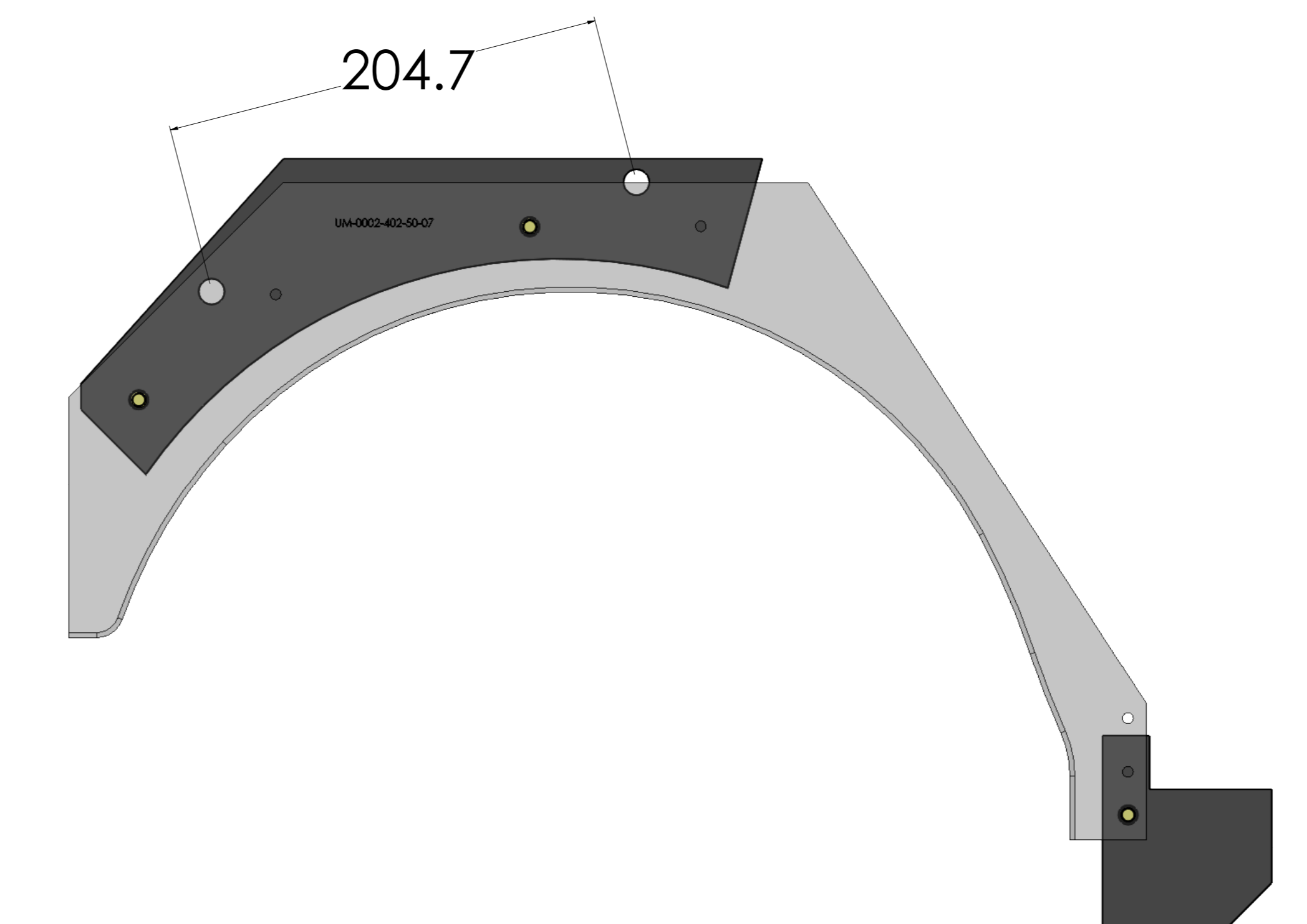

X4

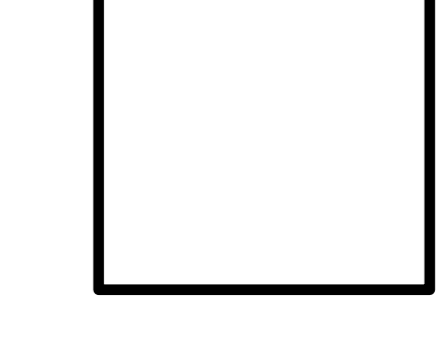

TO PGUIDE

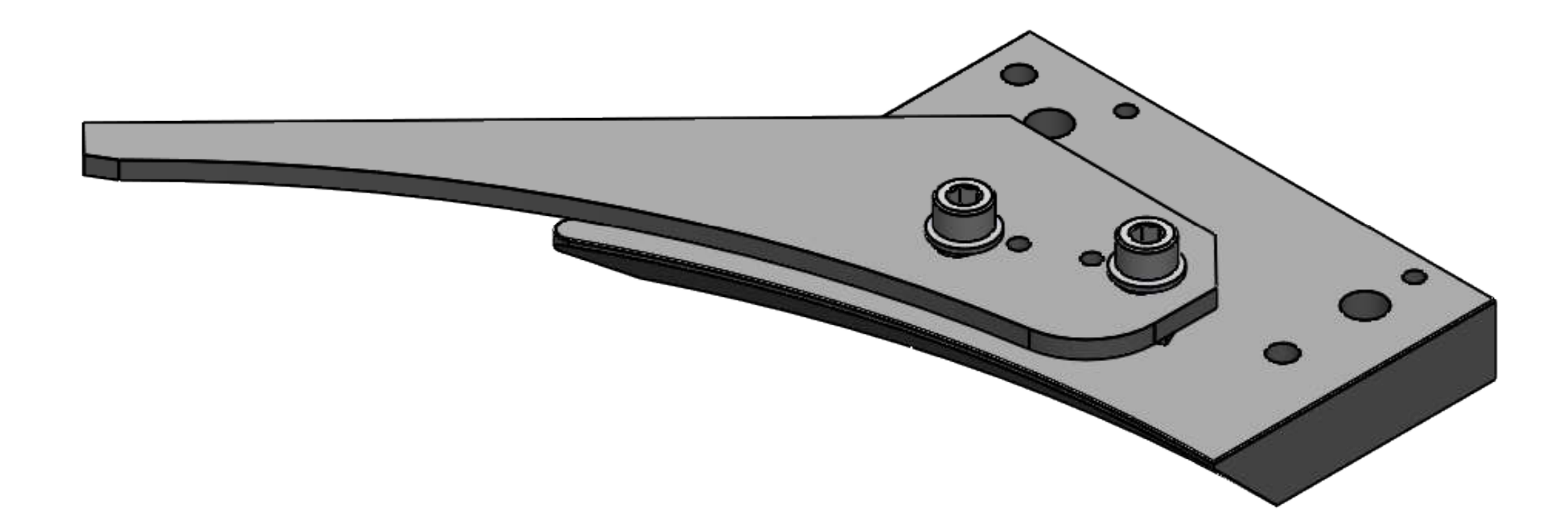

SPINDLE TIP

Form



SPINDLE TIP

Specification

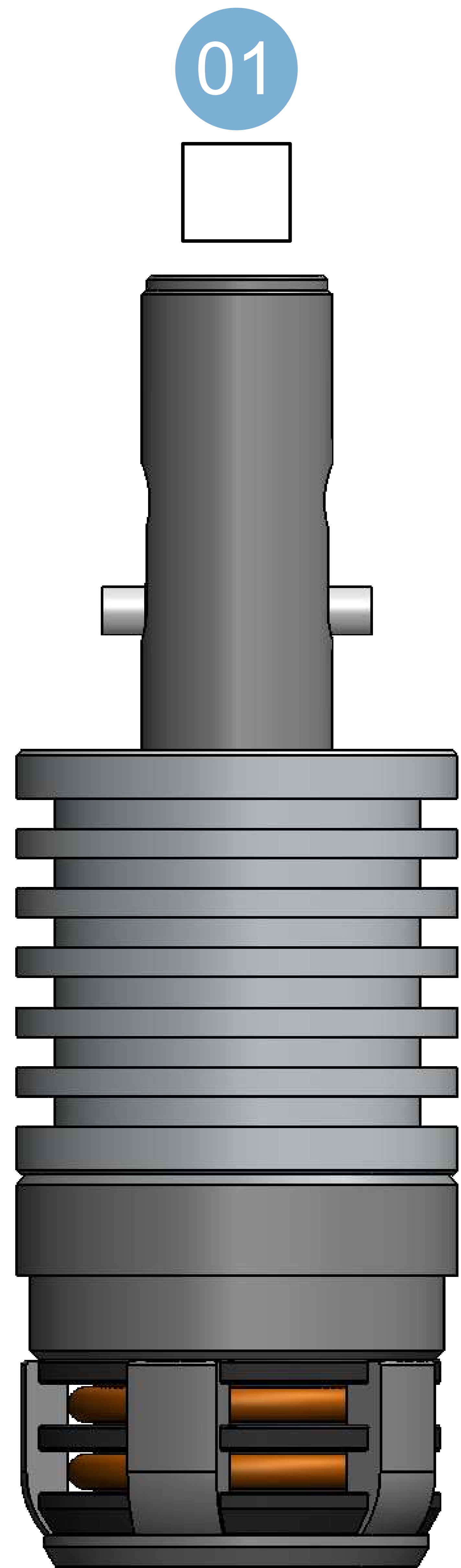

01

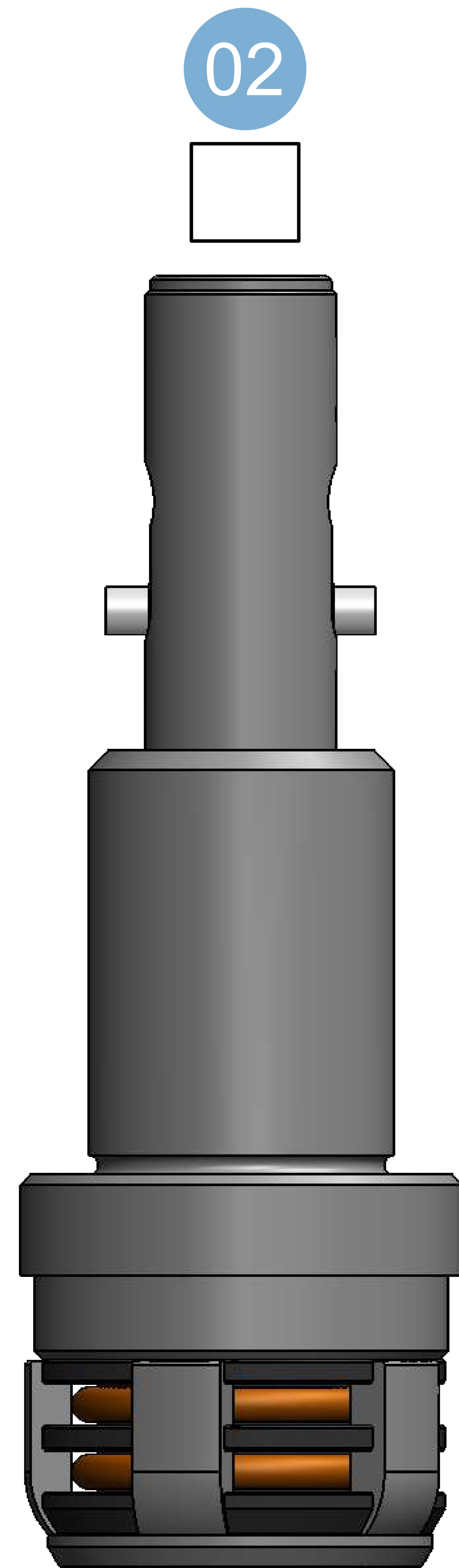
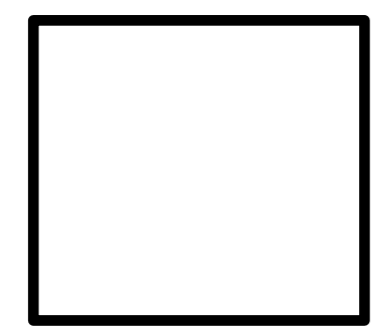

02

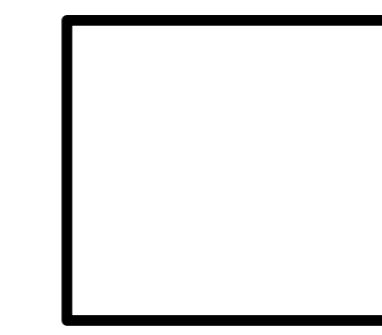

Option

X1

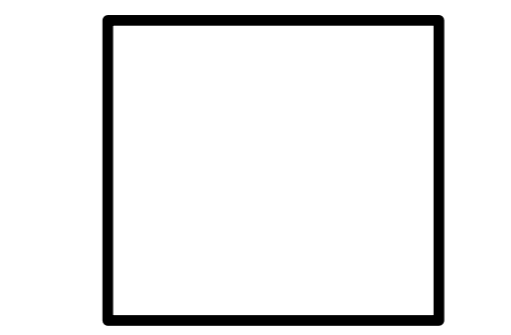

Blue

X2

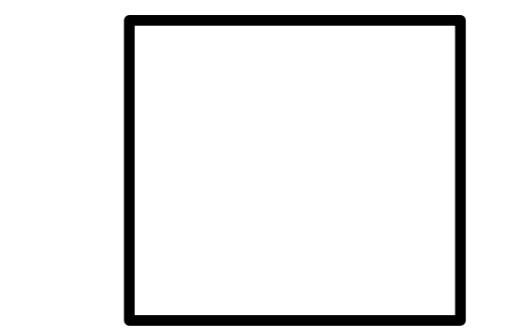

Red

X3

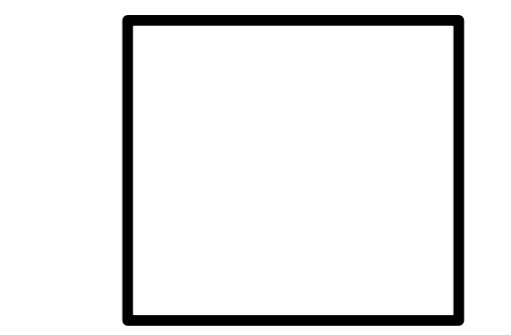

Green

X4

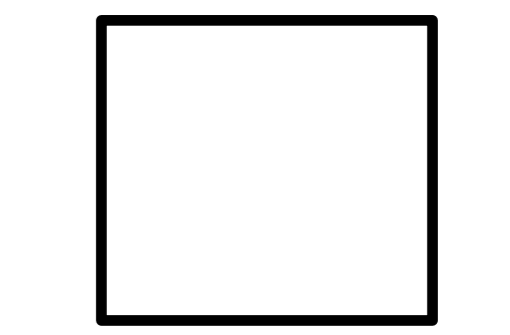

Black

UM part #

NECK	SPINDLE TIPS
1881	UMS-ST-1881-FF-SS
1810	UMS-ST-1810-FF-SS
29/21	UMS-ST-2921-FF-SS
29/25	UMS-ST-2925-FF-SS
30/25	UMS-ST-3025-FF-SS
38	UMS-ST-3800-FF-SS

TRANSFER WHEEL

 Gripper	22
 Transfer arm gripper holder	24

GRIPPER

Form

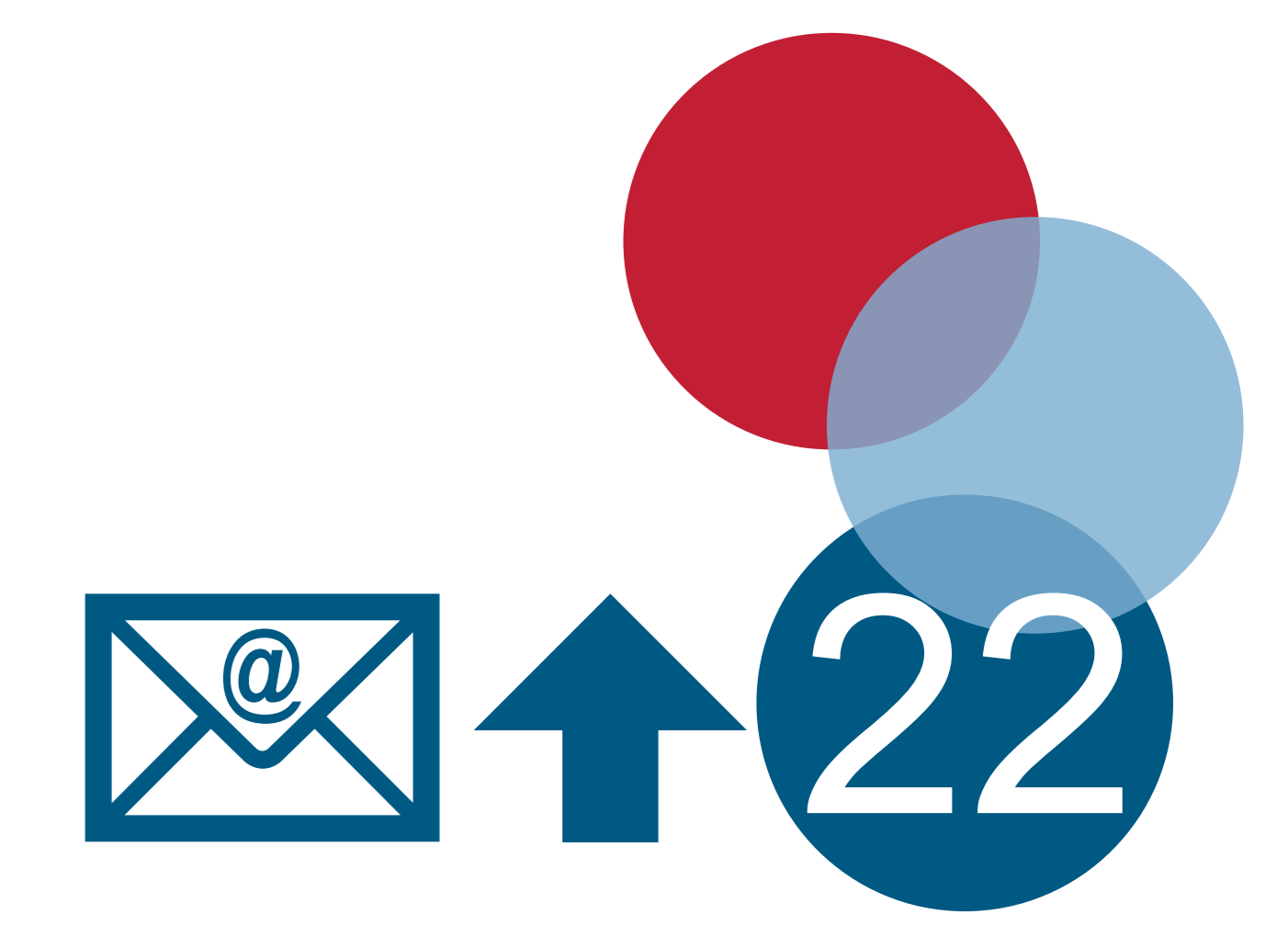

GRIPPER

Specification

01

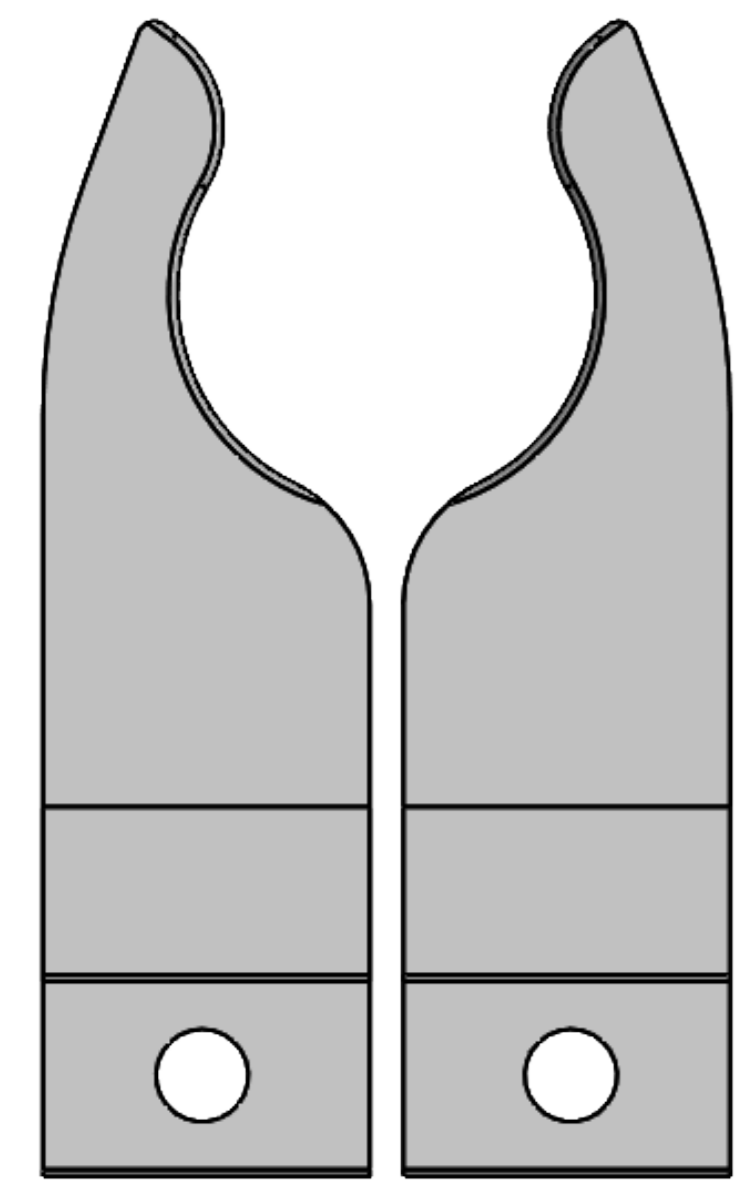
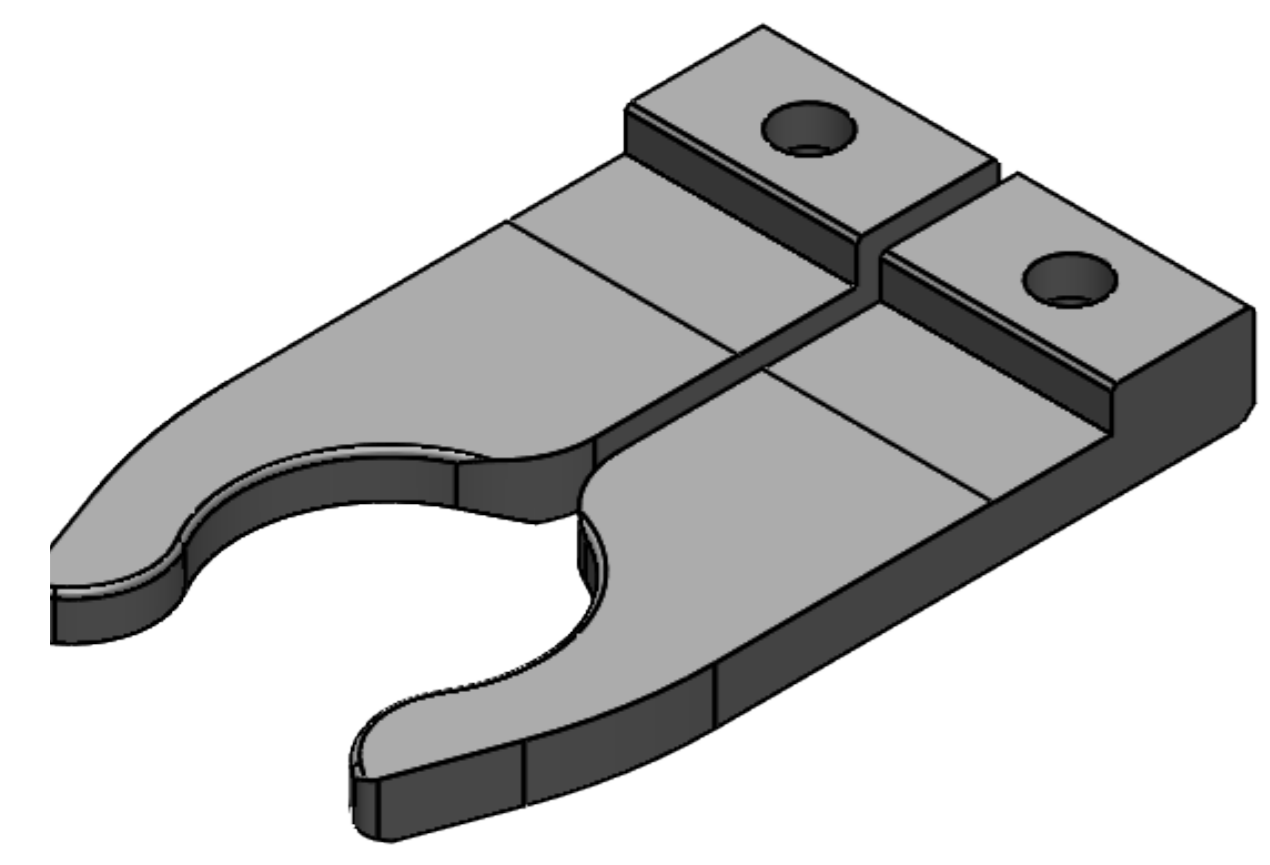
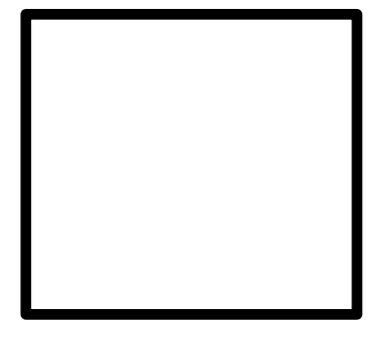

Preform

02

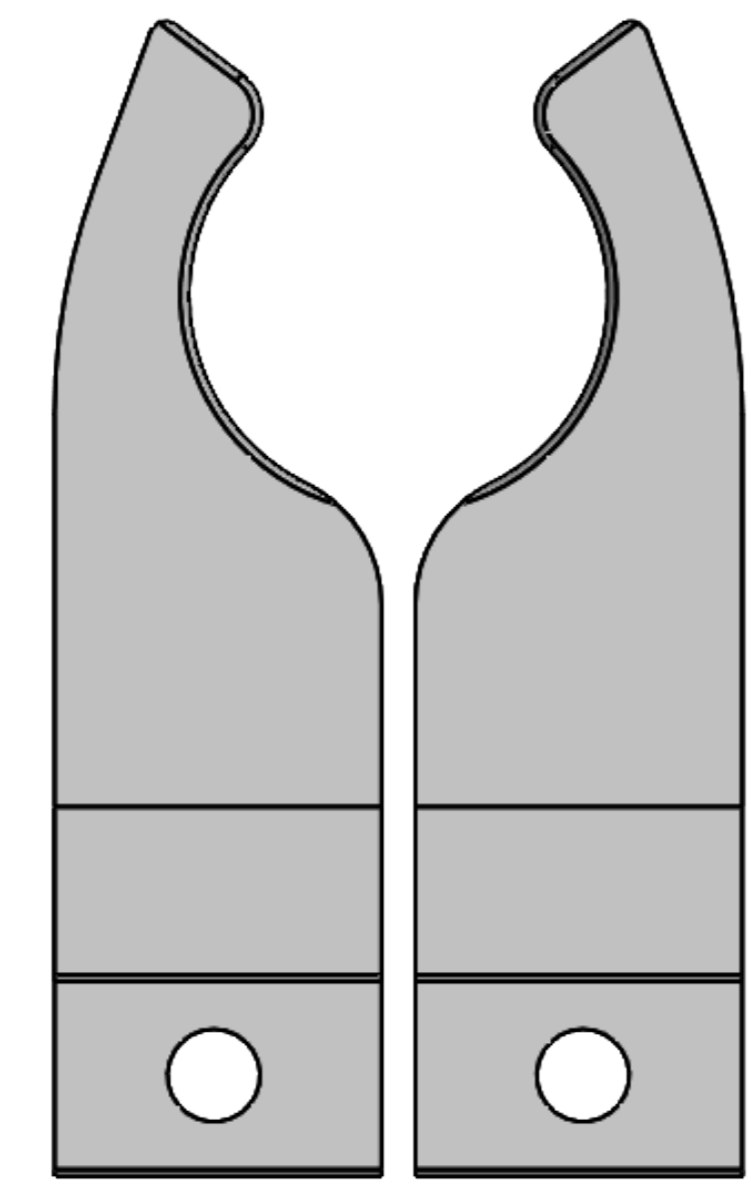
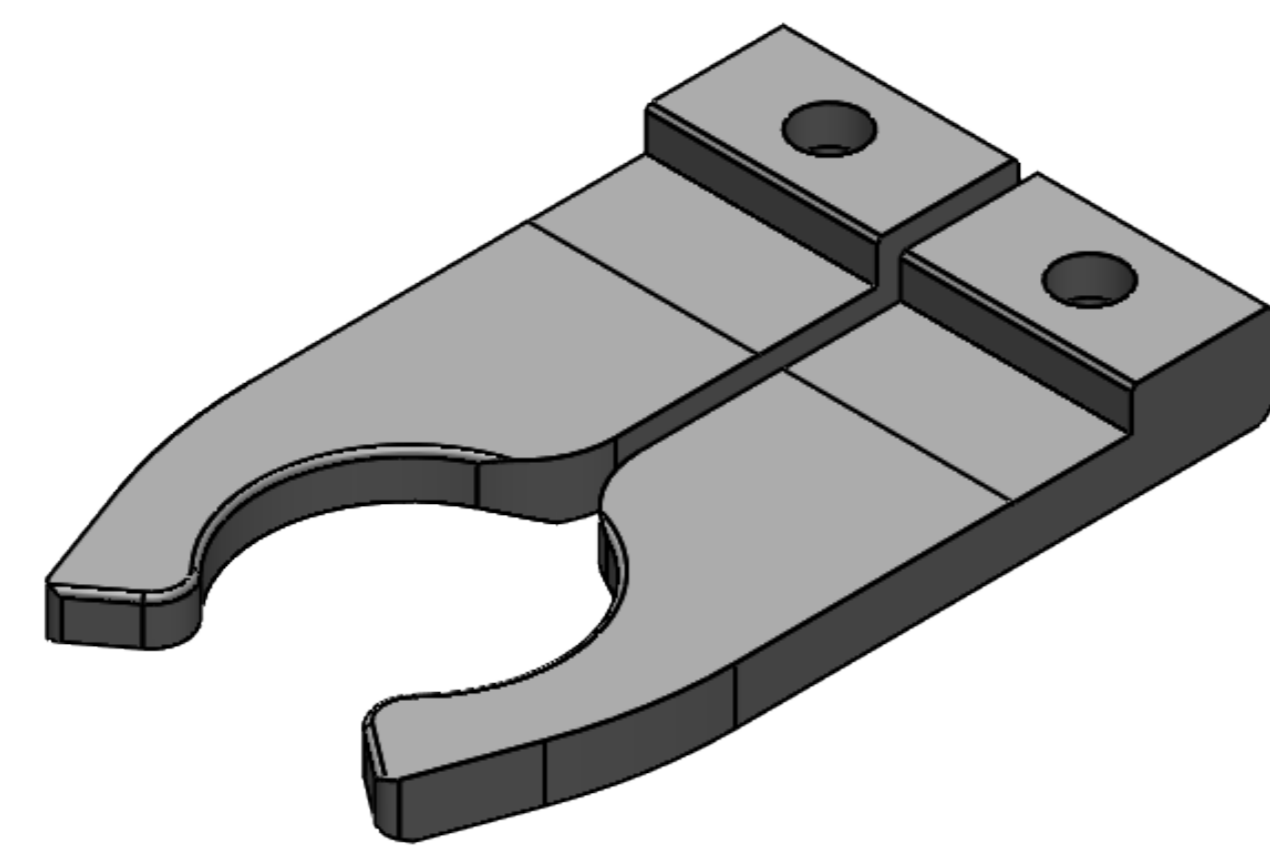
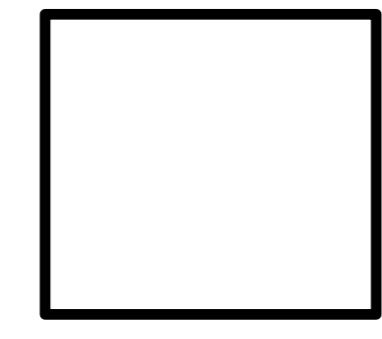

Bottle

03

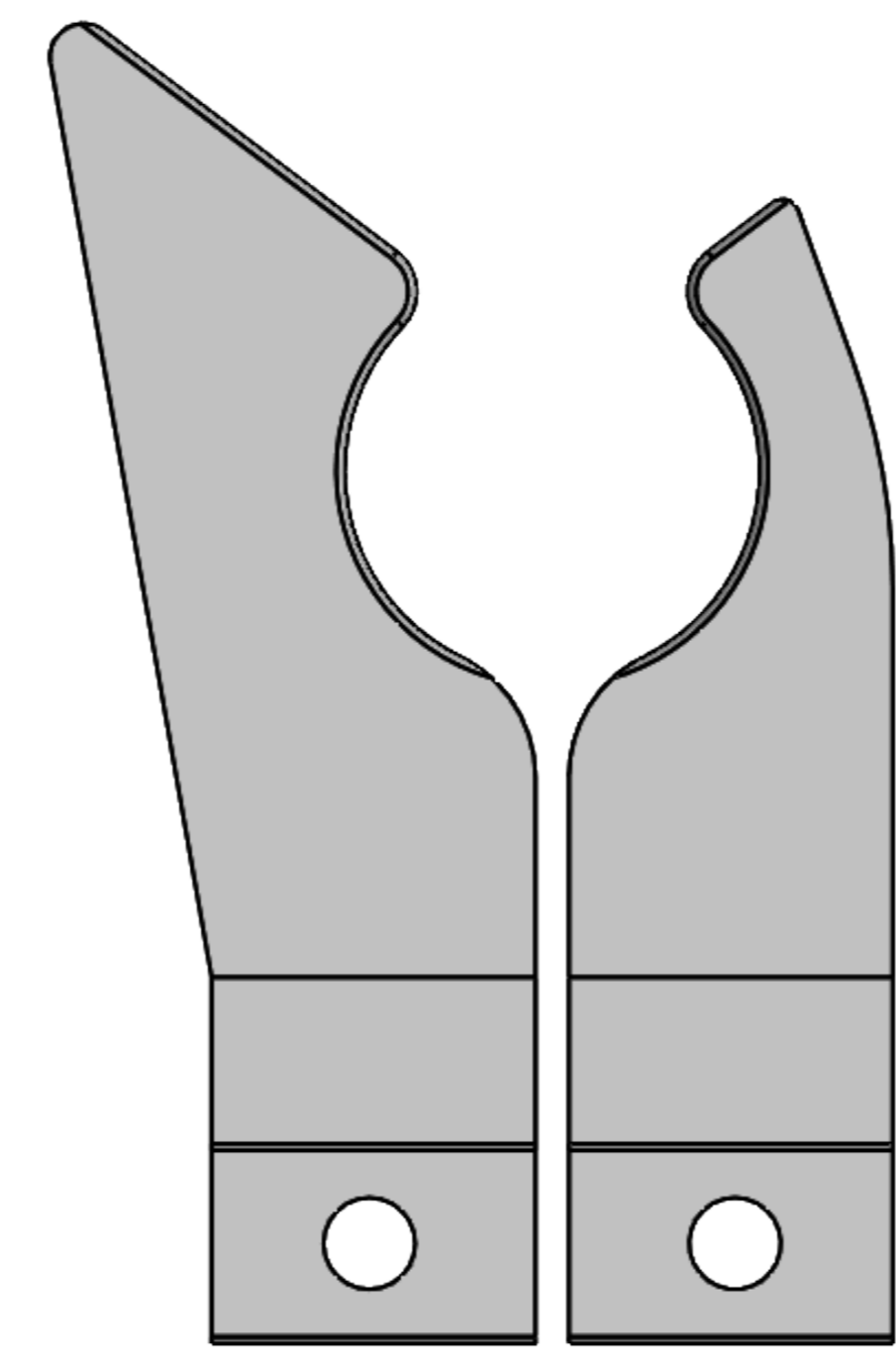
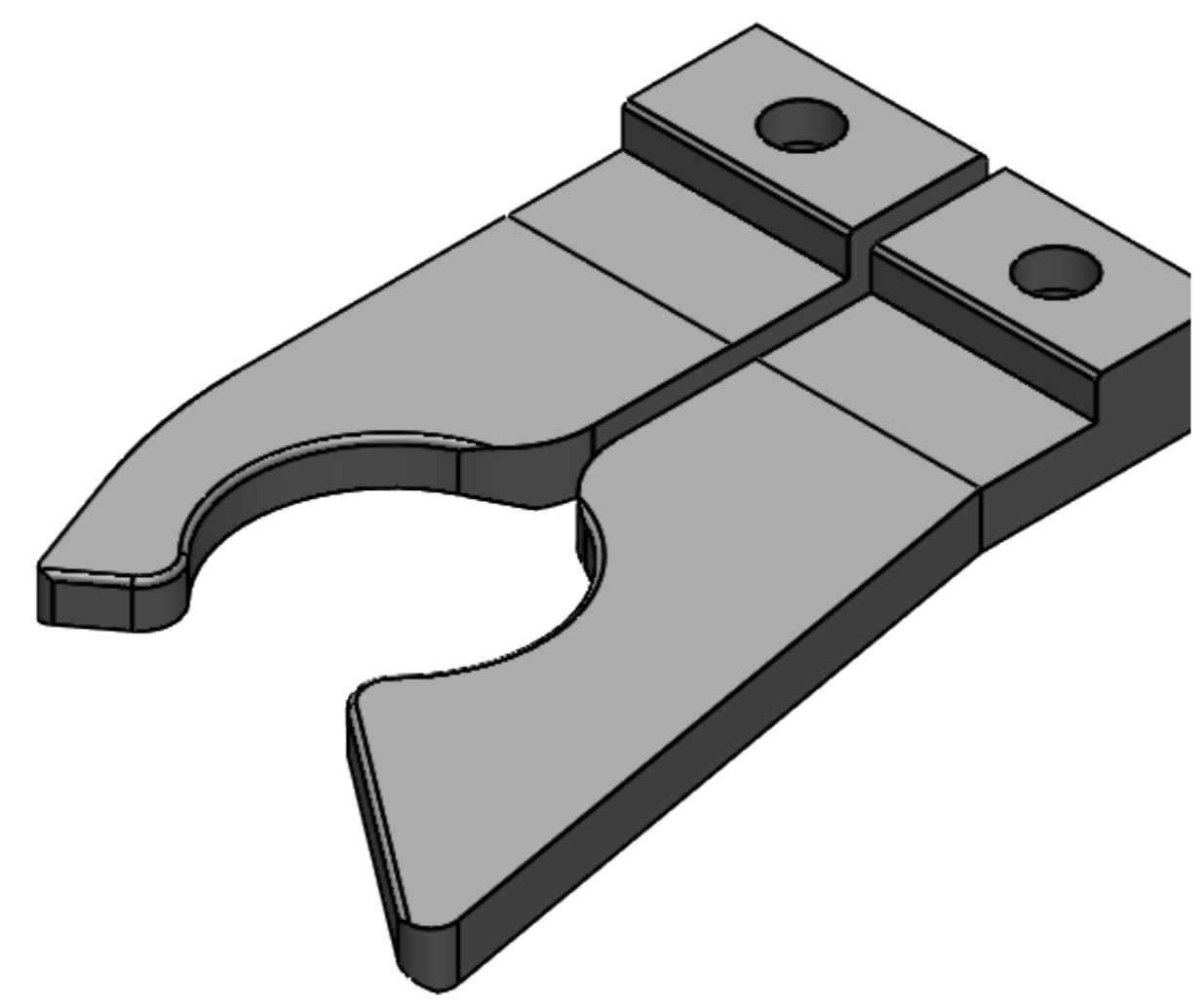
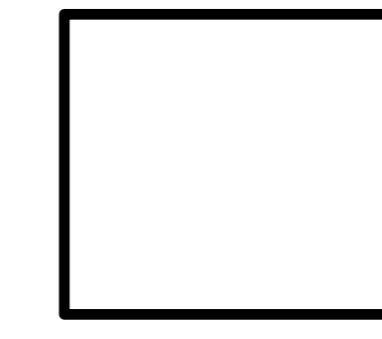

Bottle

Option

X1

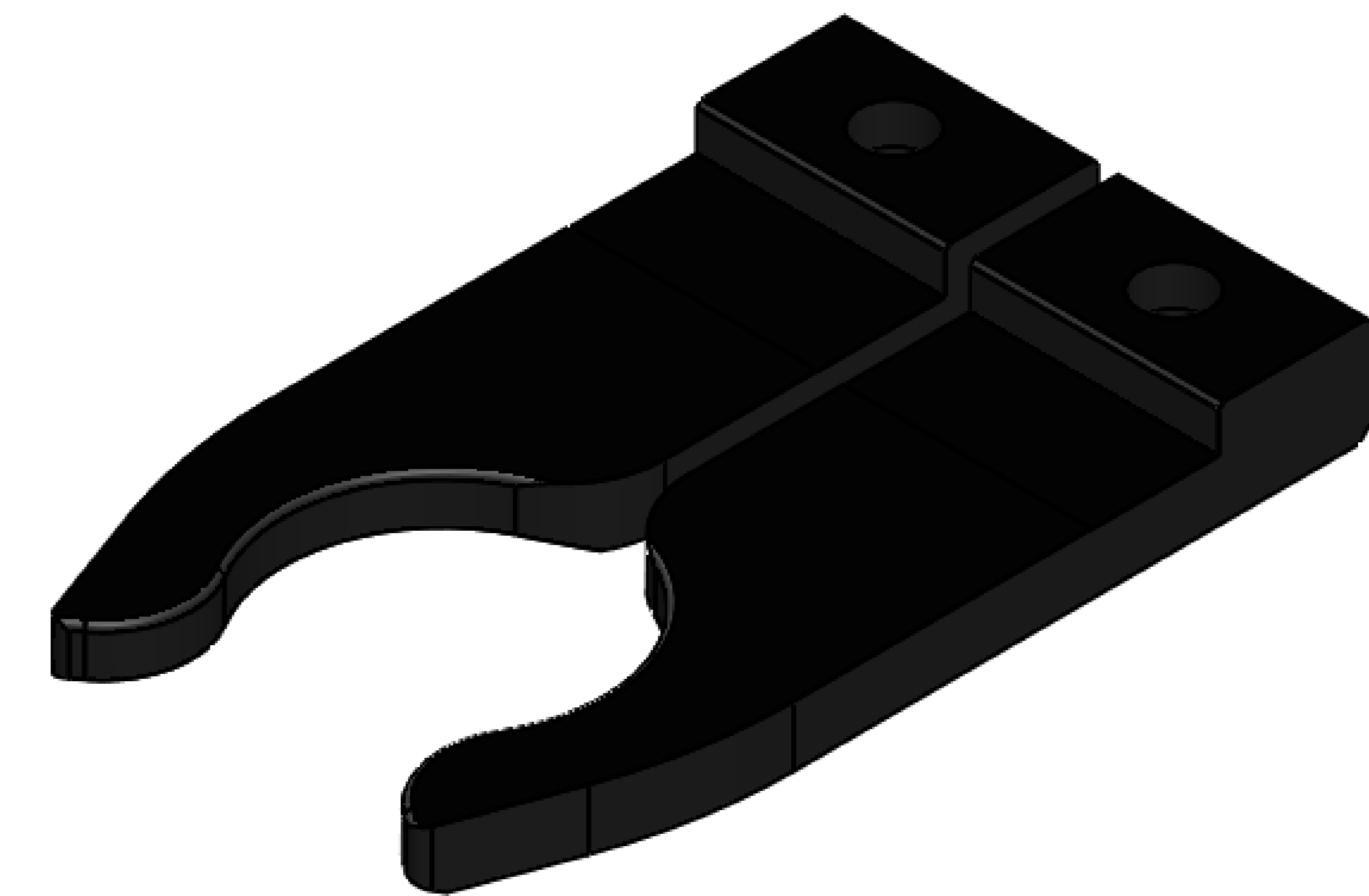
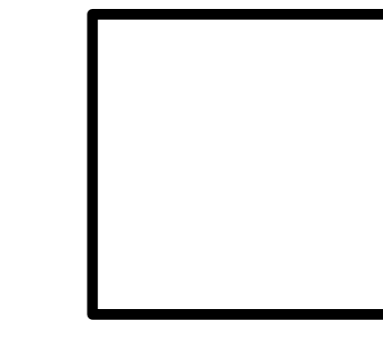

Blackened for optical inspection
Outfeed wheel

TRANSFER ARM GRIPPER HOLDER

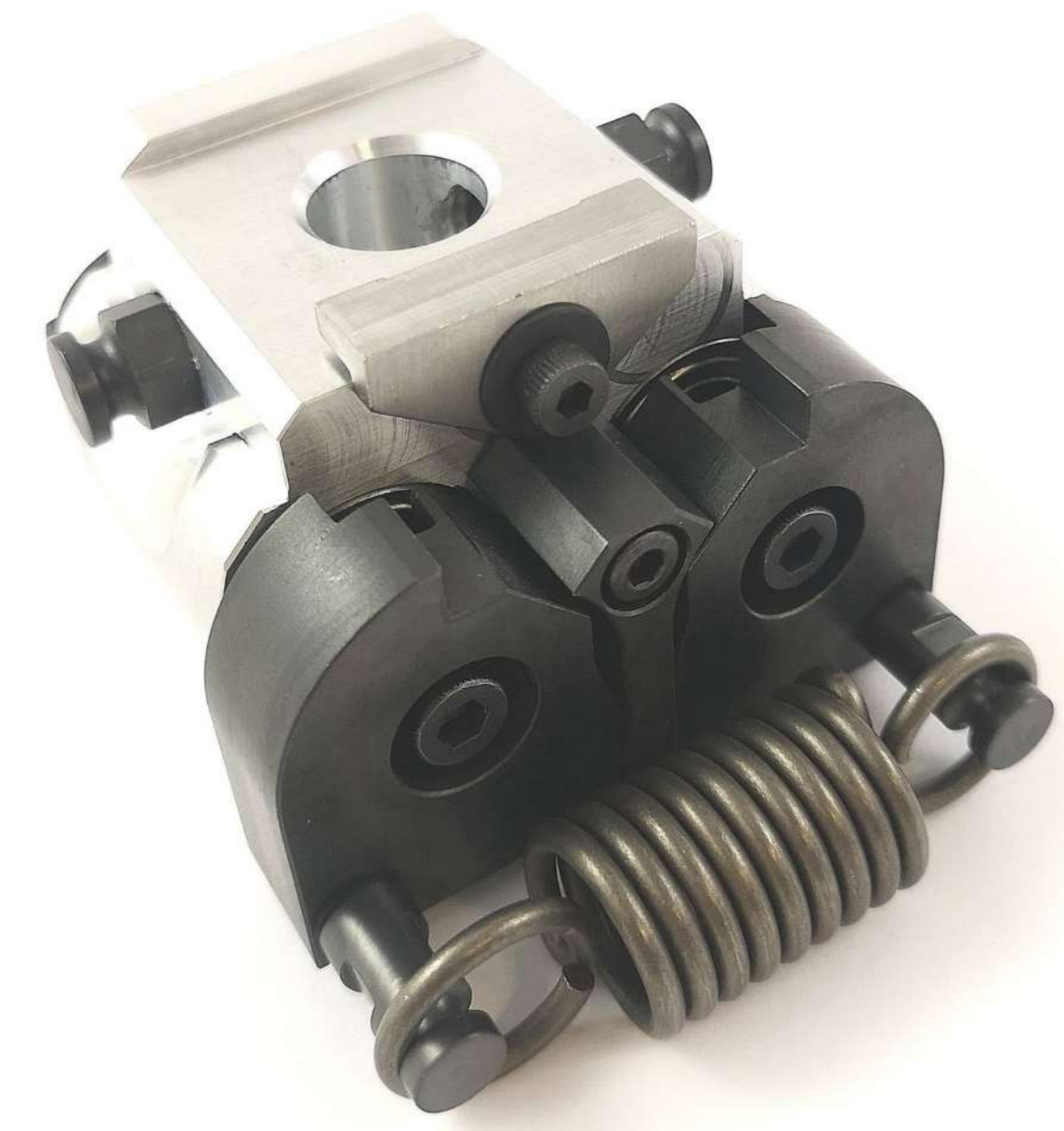

S2 Quick change
arm head

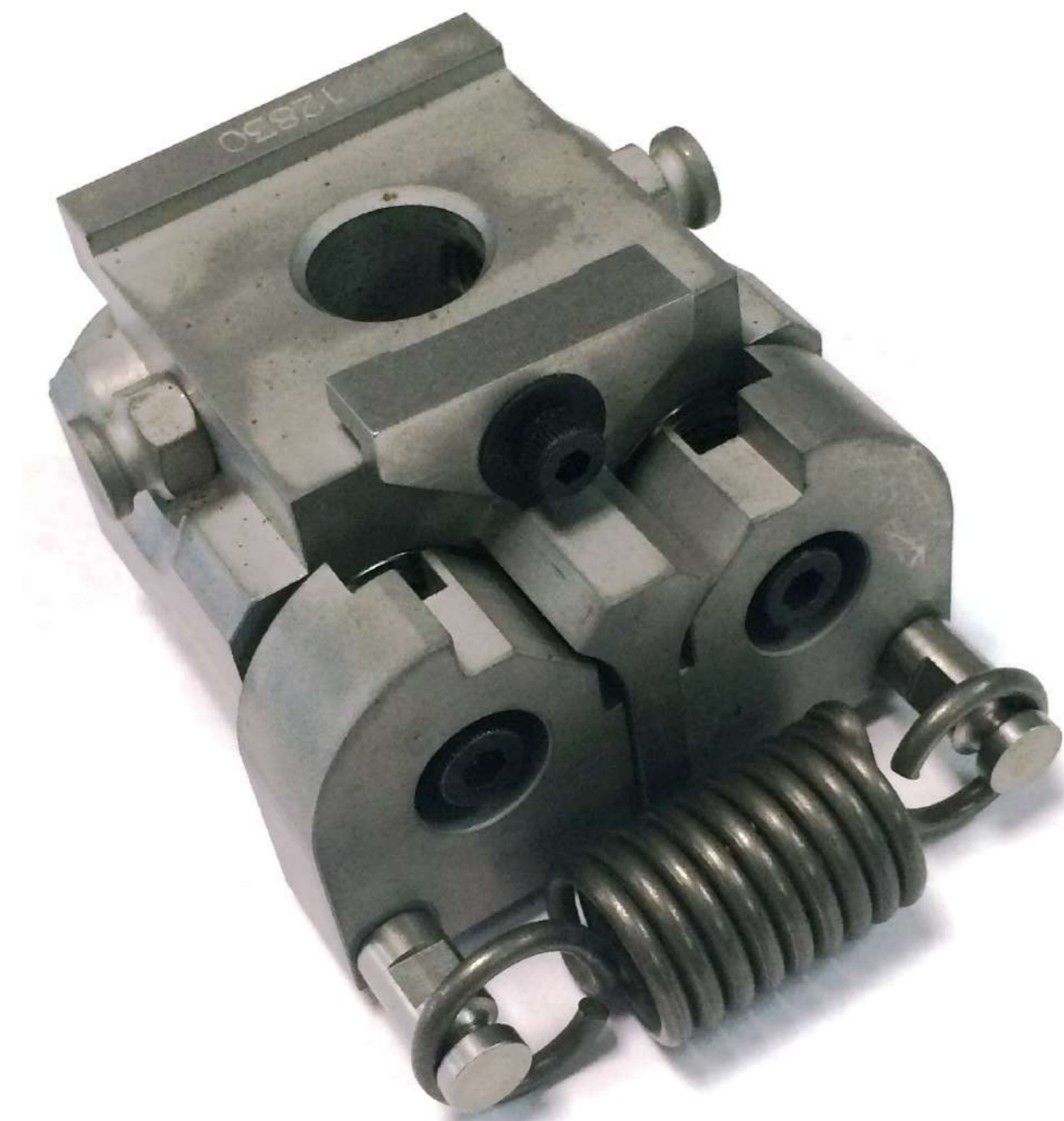

S2 Gripper holder
ass'y

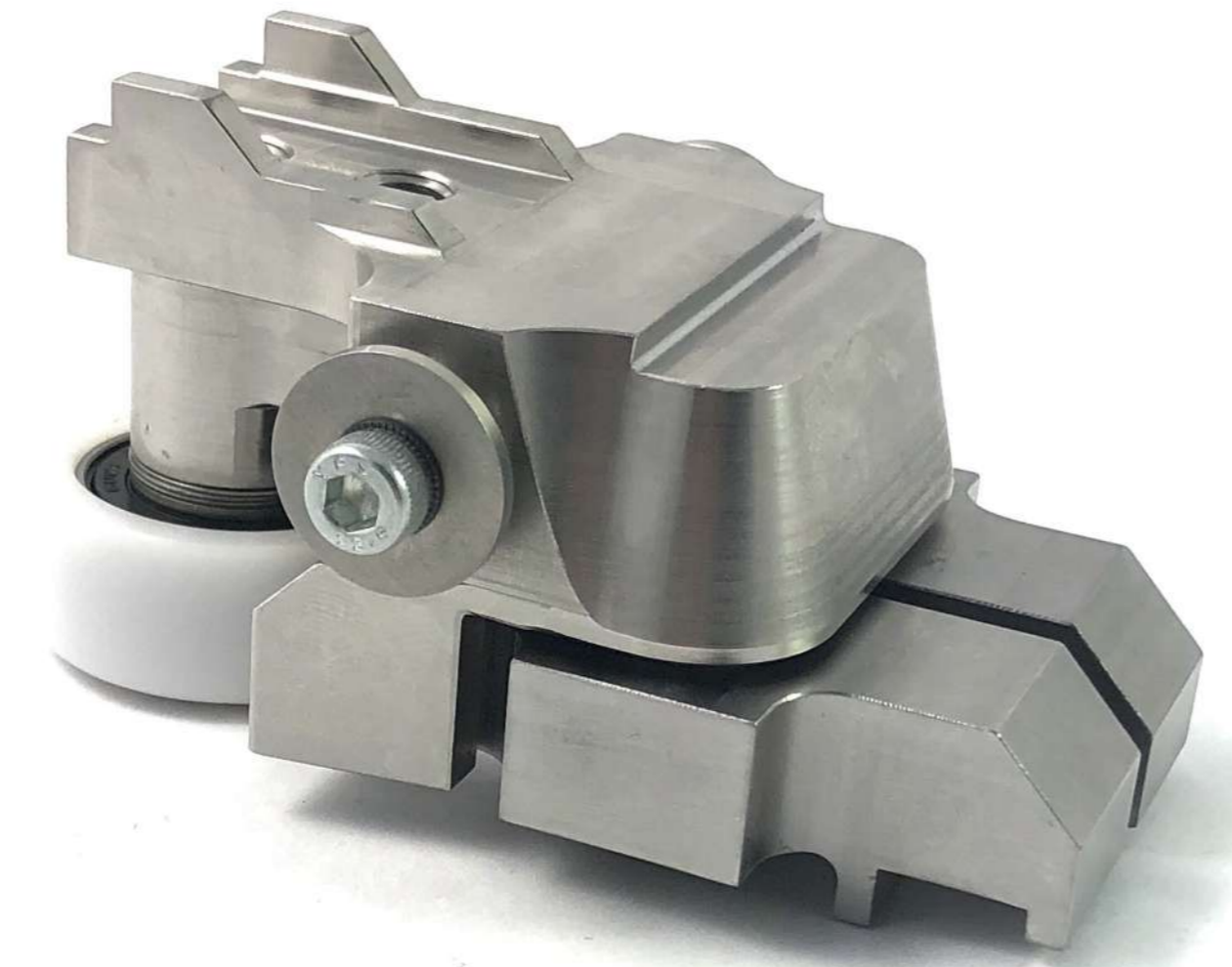

Transfer arm
Gripper holder

Benefits

Bushings replaced with bearings for improved longevity compared to OEM













Ease of maintenance with replaceable spring holders

Plug & play unit

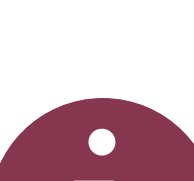
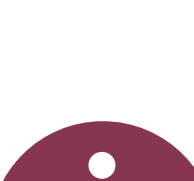
Competitive price

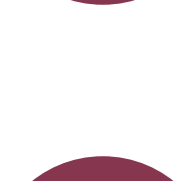
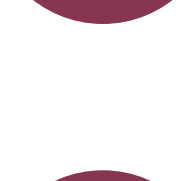
UM #	Description	Known OEM number
UMS-01113130708M02	S2 quick change arm head	01113130708
UMS-01113130708M	S2 gripper holder ass'y	01113130708
UMS-01132304808	Transfer arm - gripper holder	01132304808

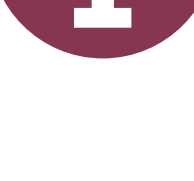
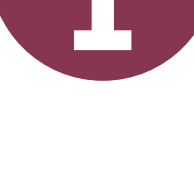
BLOWING WHEEL

 Bell	26
 Blow nozzle S2	27
 Cam	29
 Compensation valve	30
 Matrix blowing block	31
 Molds	34
 Mold hanger	35
 Pneumatic mold base	37
 Rotary union S1, S2 & Universal	38
 Shock absorber & stoping trust	42
 Stretch rod clamp	43
 Stretch rod cylinder S2	45
 Transmission belt	46
 Universal station	48
 Valve S1, S2 & Universal	51

BELL

FA

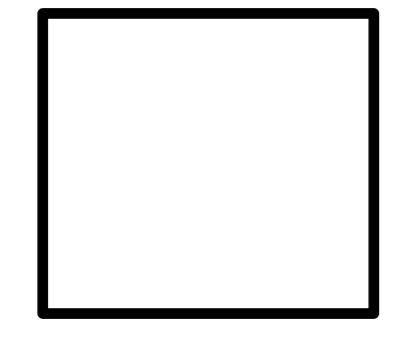

80 mm

OR

FB

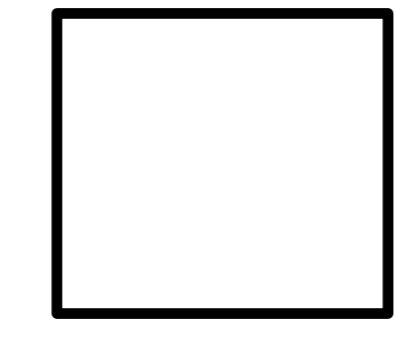

75 mm

FC

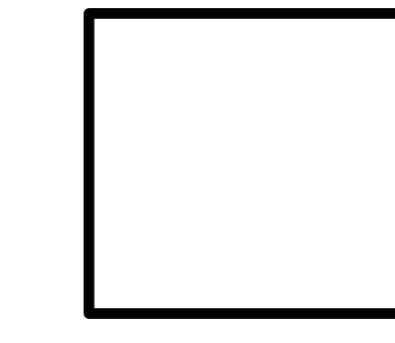

Ø 62 mm

OR

FD

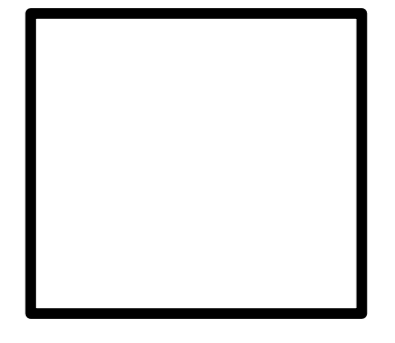

Ø 74 mm

Form

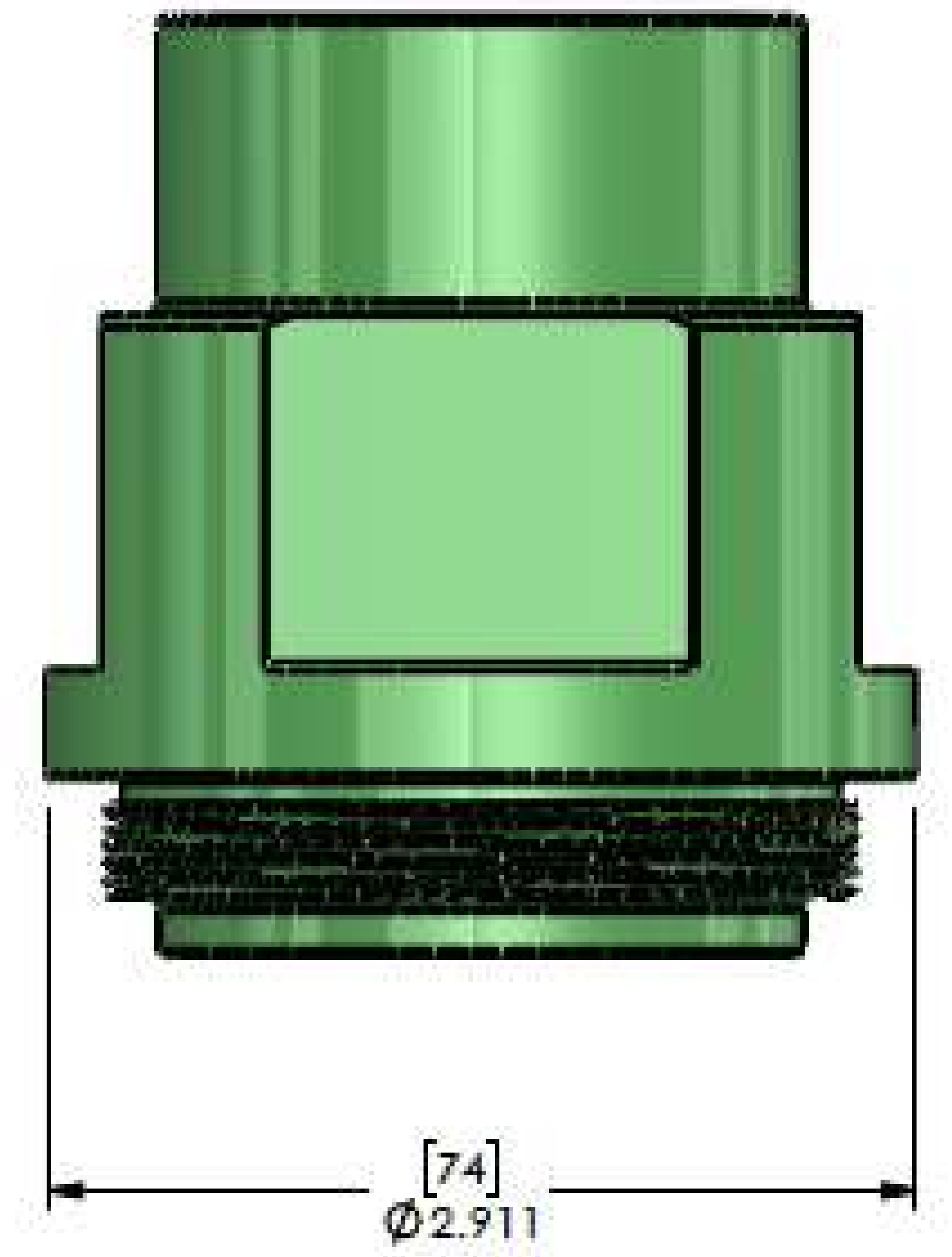
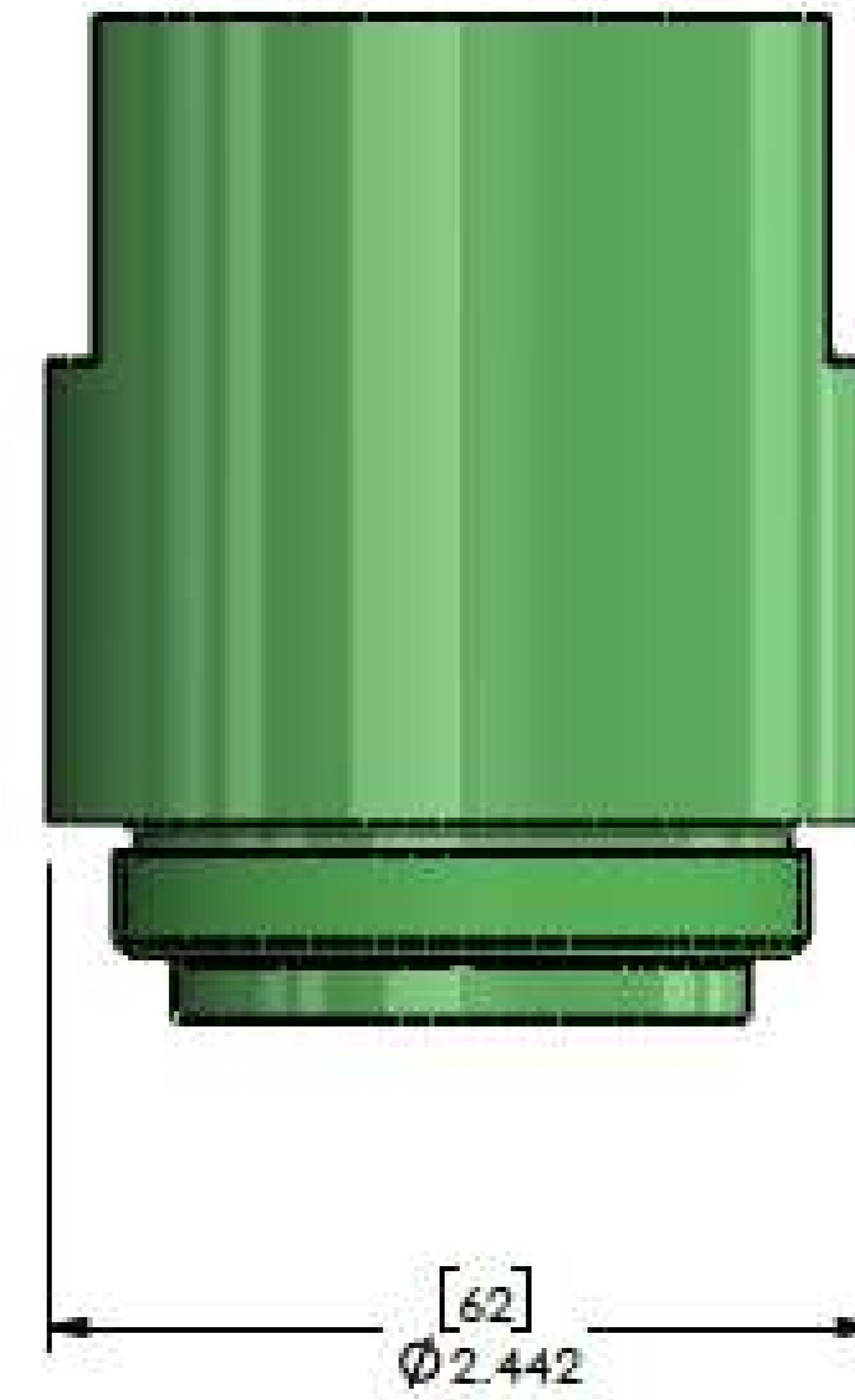
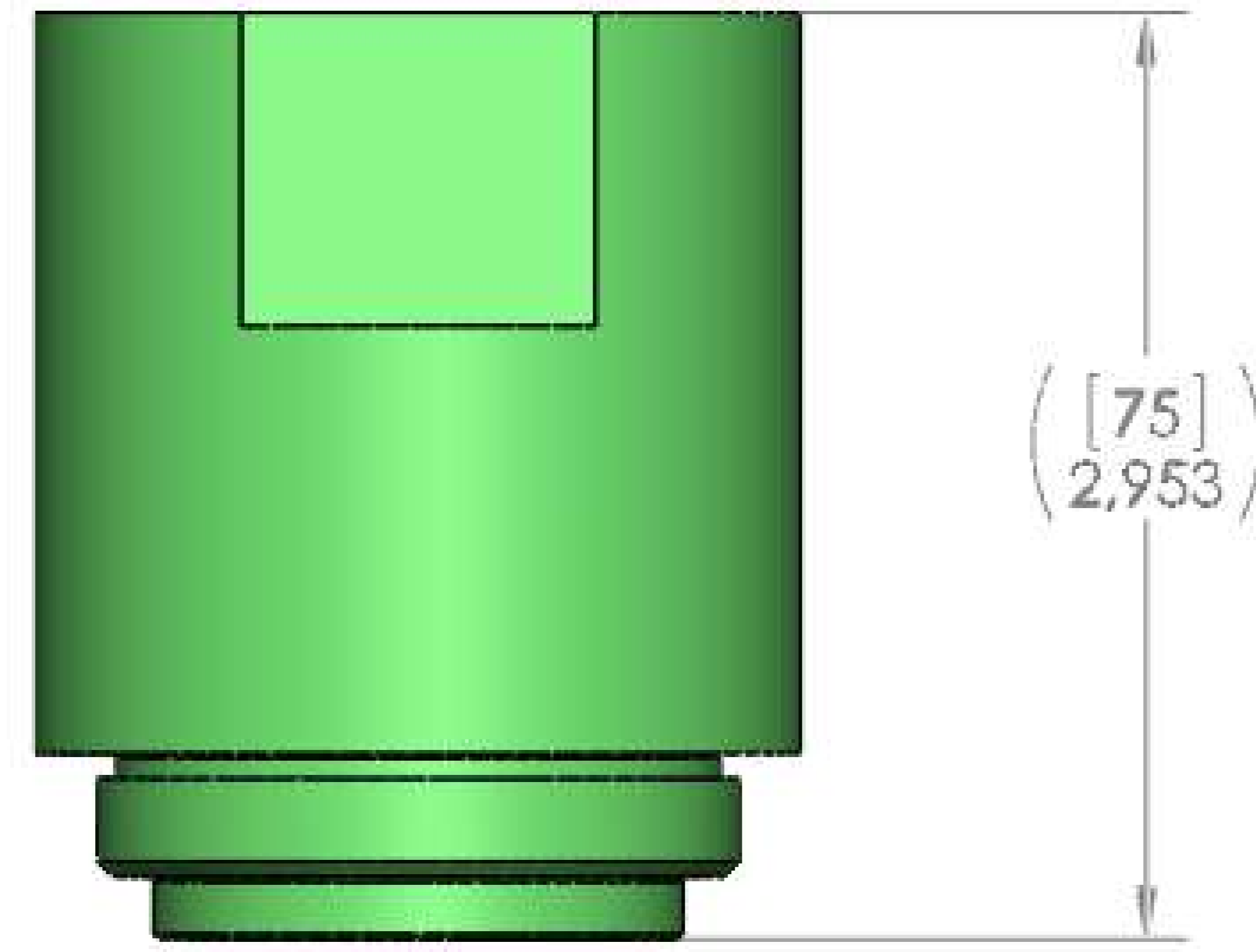
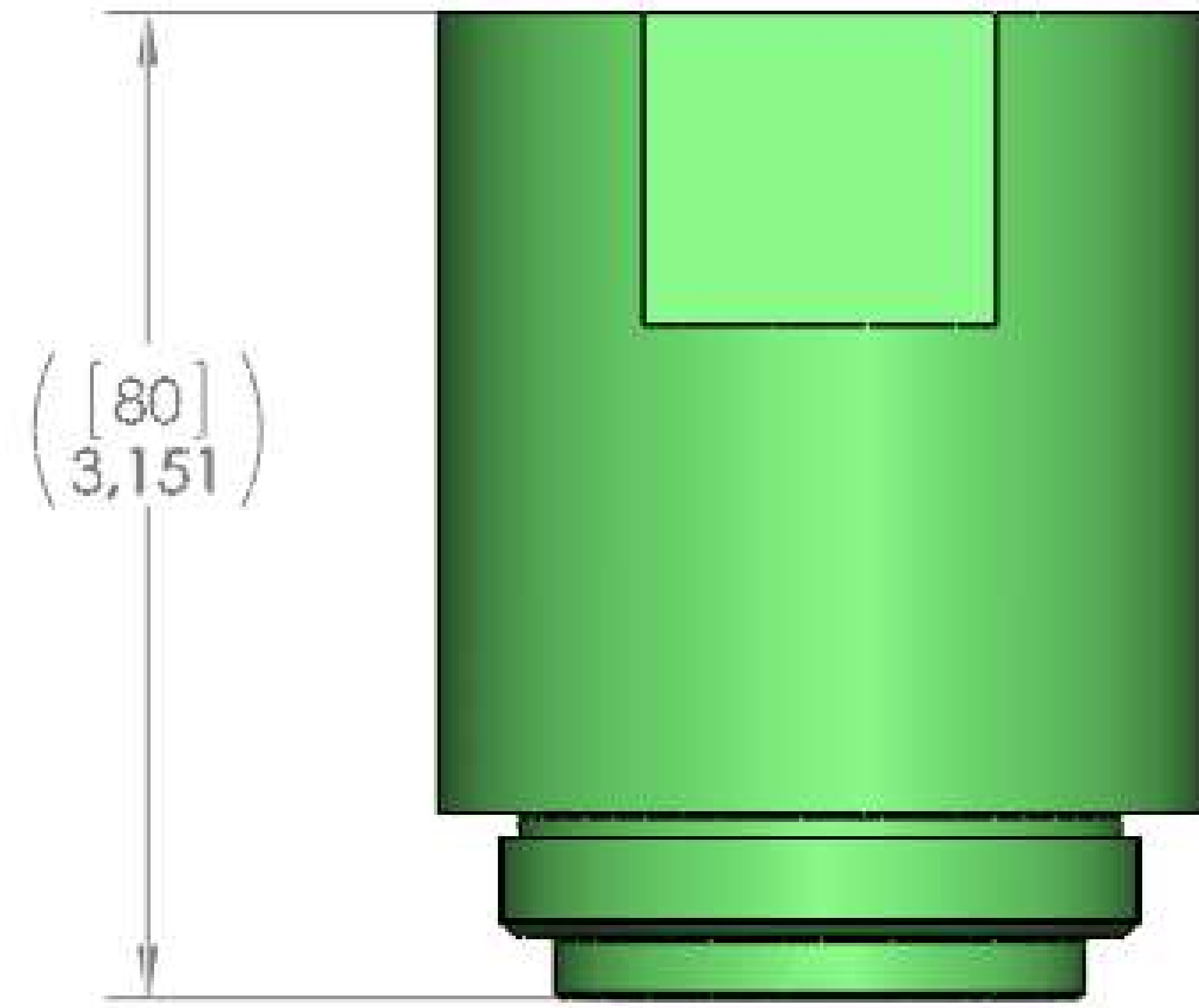

4 options :

FA + FC

FA + FD

FB + FC

FB + FD

BLOW NOZZLE S2



Benefits

- Compatible with UM ECO-Manifold for additional air saving solutions
- Directly mount MAC valve (without adapter plate)
- Greaseless design with self lubricating seals
- Plug-and-play in current configuration on machines branded Sidel* S2 blow molder
- 1 year warranty
- 2 strokes and 4-strokes available (cold set and heat set)
- Repair kit available

Standard components



Bell



i Diffuser

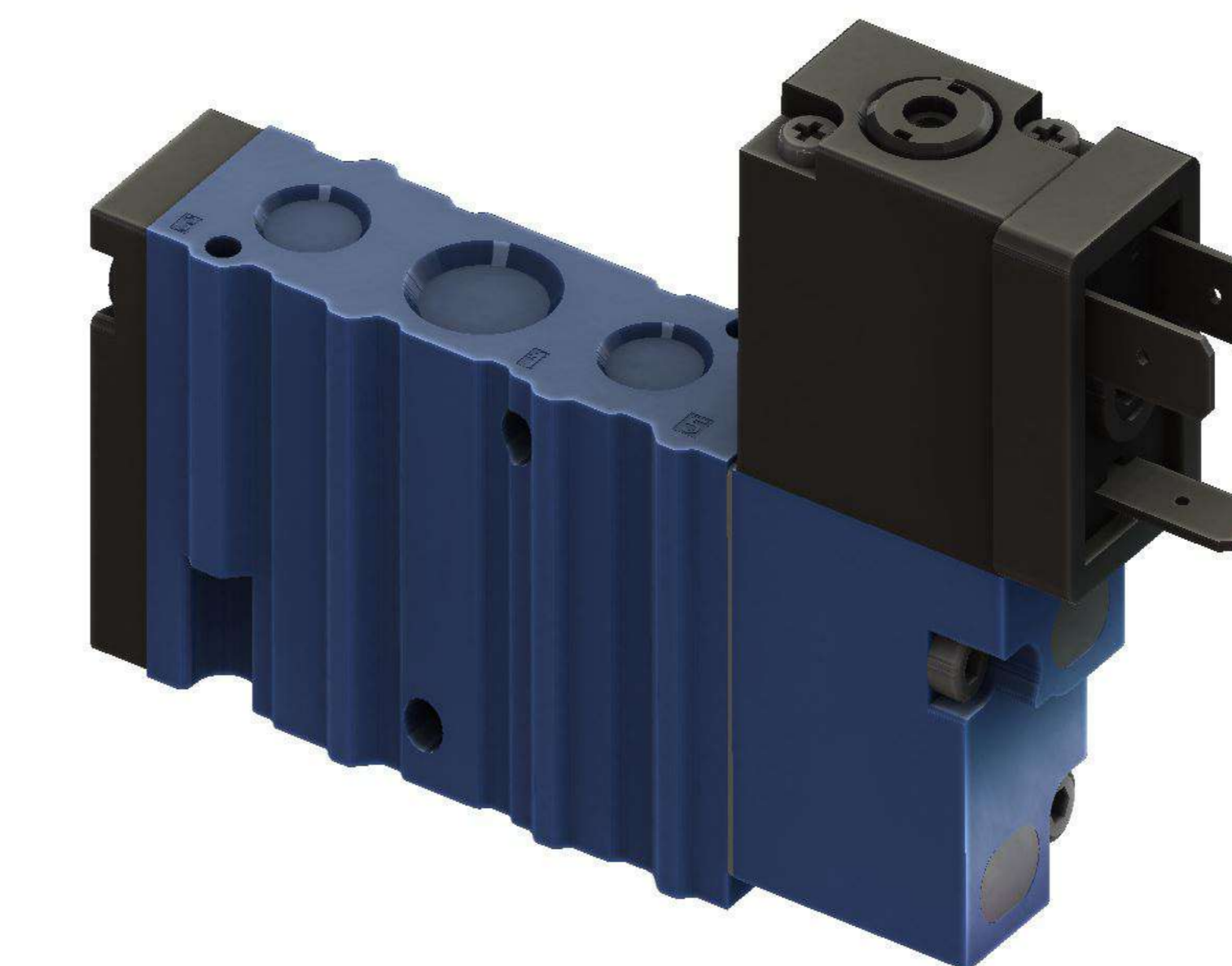

Pilot valve
0002-001-08-08



i Tube spacer

UM #	Description	Known OEM number
UMS-BN-2S-S2	2 stages blow nozzle valve	01111192202 to 06 01111192207 to 10
UMS-01120323905M	4 stages blow nozzle valve	01111190001 to 05 01120323901 to 05 01111190006 to 08

BLOW NOZZLE S2

Standard components



UM #	Description	Known OEM number	UM #	Description	Known OEM number
UMS-01074608901	Tube spacer	01074608901	UMS-01068296702	S1 diffuser 14 mm	01068296702
UMS-01074200601	Tube spacer long	01074200601	UMS-01068090802	S1 diffuser 15 mm	01068090802
			UMS-01072746004	S2 diffuser 14mm	01072746004
			UMS-01124229103	Universal diffuser 14mm	01124229103

CAM



Benefits

Better price

High quality assembly

Same hardness as OEM

UM #	Description	Known OEM number	UM #	Description	Known OEM number
UMS-01064447302	S1 SBO24 transfer arm cam	01064447302	UMS-01124151802	Universal SBO20 up down cam	01124151802
UMS-01071823303	S2 SBO 10-12-14 HS stretch rod down cam HS	01071823303	UMS-01124151802M	Universal SBO20 up down cam (VAB)	01124151802
UMS-01112199004	S2 SBO 10-12-14 stretch rod down cam	01112199004	UMS-01128565001	Universal SBO 30 up down cam	01128565001
UMS-01151311003	S2 SBO20 mold base up down cam rebuilt	01151311003	UMS-01126675502	Universal SBO20 stretch rod down cam	01126675502
UMS-01072325503	S2 SBO20 – stretch rod up cam	01072325503	UMS-01131386601	Universal SBO 30 open & close cam	01131386601
UMS-01071866103	S2 SBO20 bottom down cam	01071866103	UMS-01131388901	Universal SBO 30 open & close cam	01131388901
UMS-01072735202	S2 SBO20 bottom up cam	01072735202	UMS-01150659702	Matrix SBO20 preform transfer table cam	01150659702
UMS-01074612701	S2 SBO20 locking Cam	01074612701 / 01112912905	UMS-01182584401	Matrix SBO20 base cam	01182584401
UMS-01112912905	S2 SBO20 locking cam	01112912905	UMS-01122184805	Matrix SB020 open & close cam	01122184805
UMS-01073169801	S2 SBO20 unlocking cam	01073169801 / 01111240503	UMS-01147746501	Load cam	01147746501
UMS-01111240503	S2 SBO20 unlocking cam	01111240503	UMS-01147745402	Loading/unloading cam	01147745402
UMS-01118747801	S2 SBO20 preferential unloading cam	01118747801	UMS-01127286303	Retractable cam	01127286303
UMS-01116742703	S2 SBO28 bottom down cam	01116742703	UMS-01170631301	Cam guide	01170631301
UMS-01116742602	S2 SBO28 bottom up cam	01116742602	UMS-01158830702	Cam guide	01158830702
UMS-01111411705	S2 SBO16-18-20 open & close cam	01111411705	UMS-01152697904	Cam	01152697904

COMPENSATION VALVE S2/S2 + UNIVERSAL & KRONES



OEM Version



UM improved version



OEM Universal version

Rebuilt parts



Rebuilt parts for universal compensation valve
UMS-01134426801



Compensation valve rebuilt parts
UMS-01123429701KR



Compensation valve maintenance
UMS-234297-N7BAR-MK

Standard components

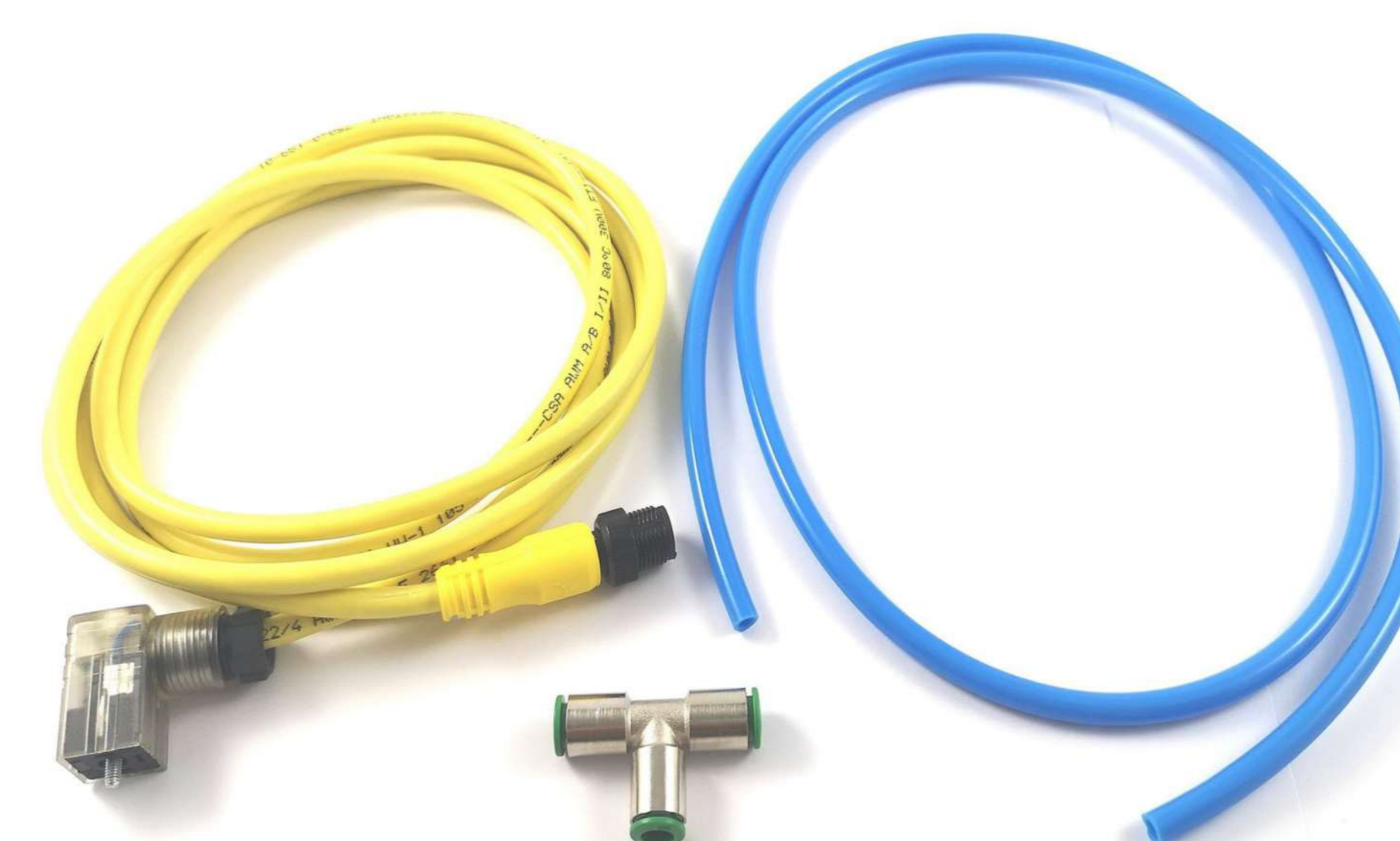

Cable, tubing & metal connector for compensation valve
UMS-234297-N7BAR-KIT



Compensation pilot valve
UMS-234297-N7BAR-PV

Benefits

- Standard MAC pilot valve
- Higher longevity compared to OEM
- More reliable compared to OEM
- No core return
- 1 year warranty

UM #	Description	Known OEM number
UMS-234297-N7BAR-WC	Improved compensation valve	01123429701

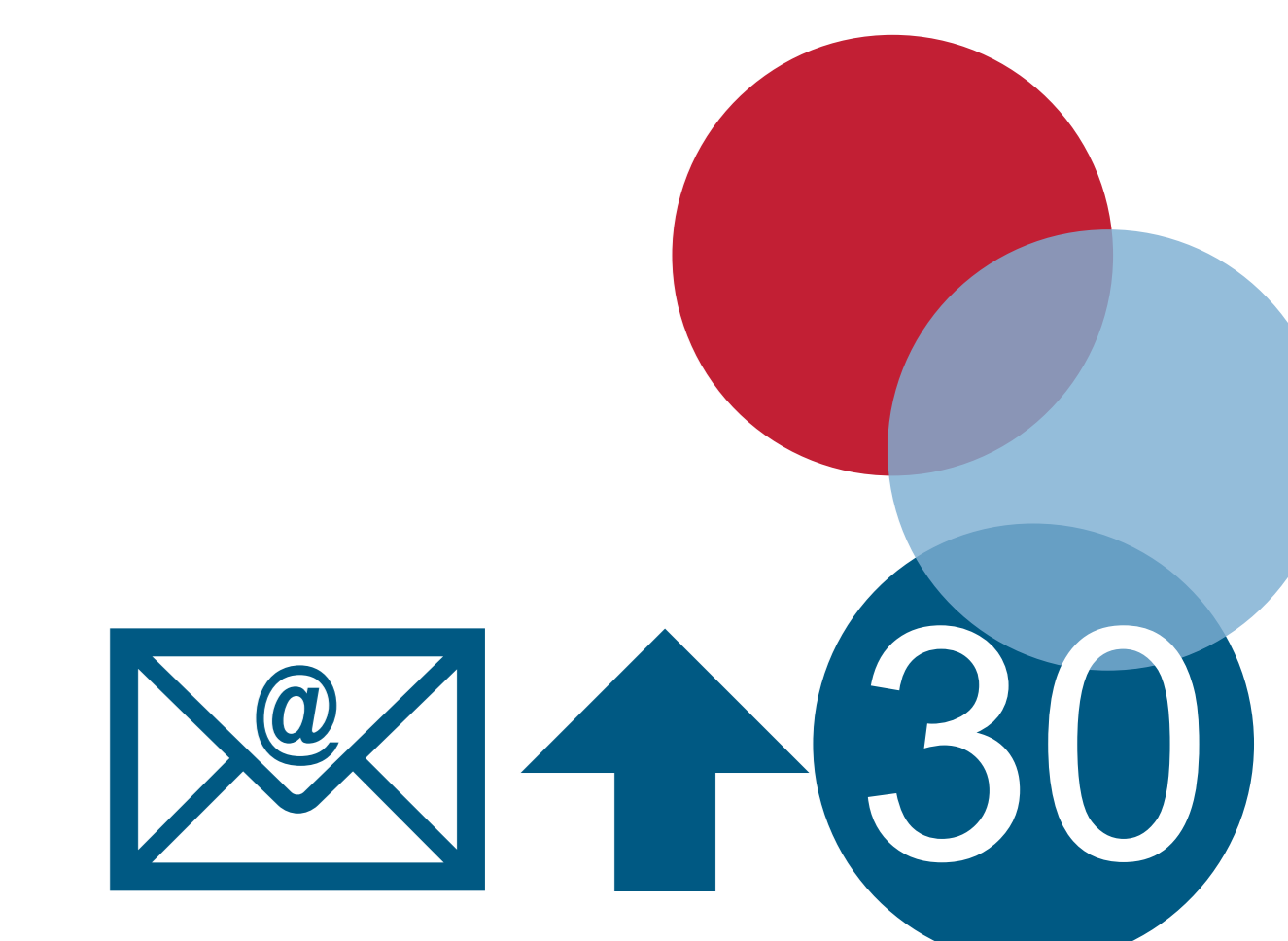

MATRIX BLOWING BLOCK

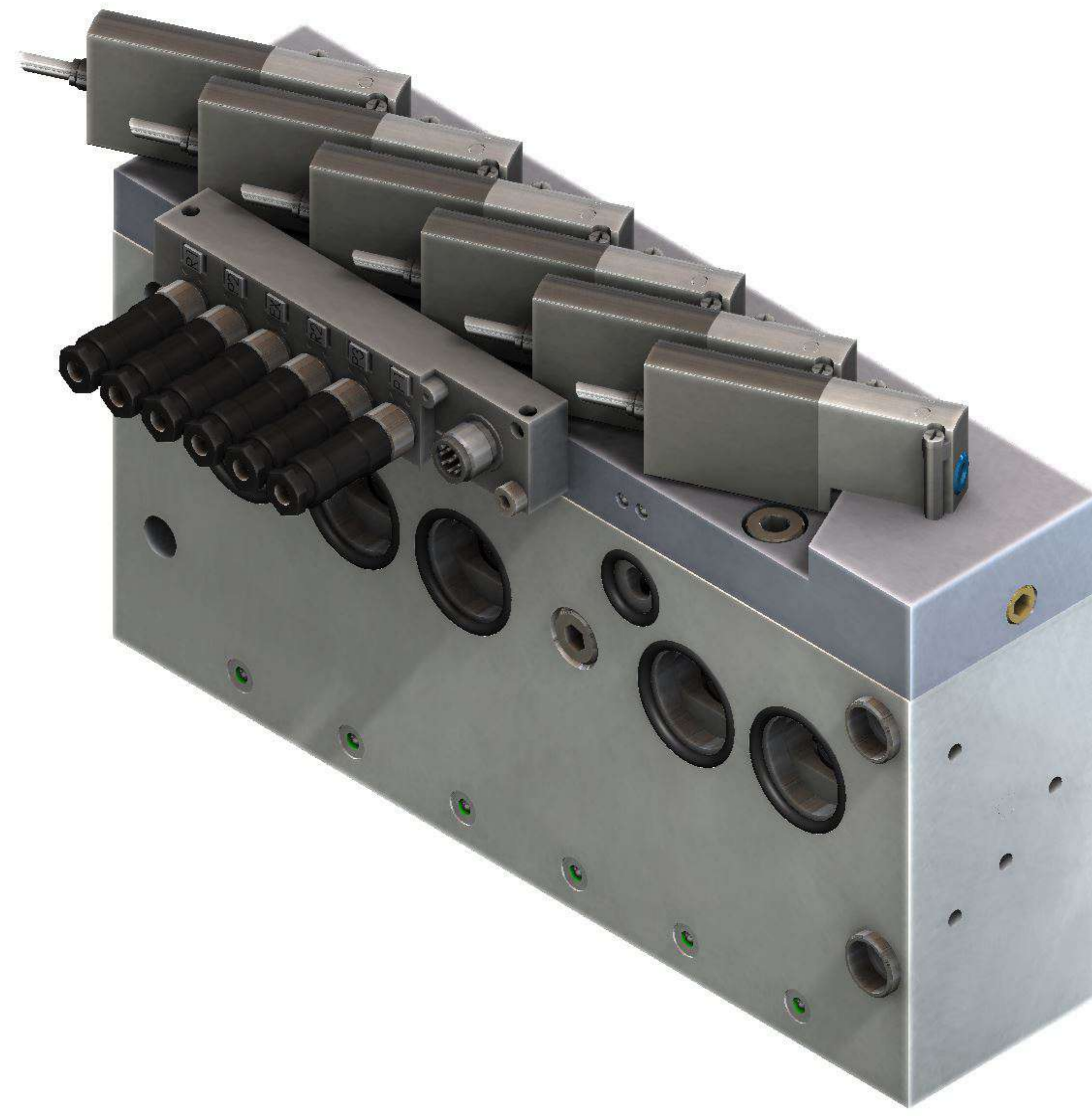

Main body improved for conversion OEM
0002-604-90-70

Cover without valve
0002-604-90-50



Set of 6 pistons
(5X P1/P2/R & 1 Exhaust)
UMS-00000241534M

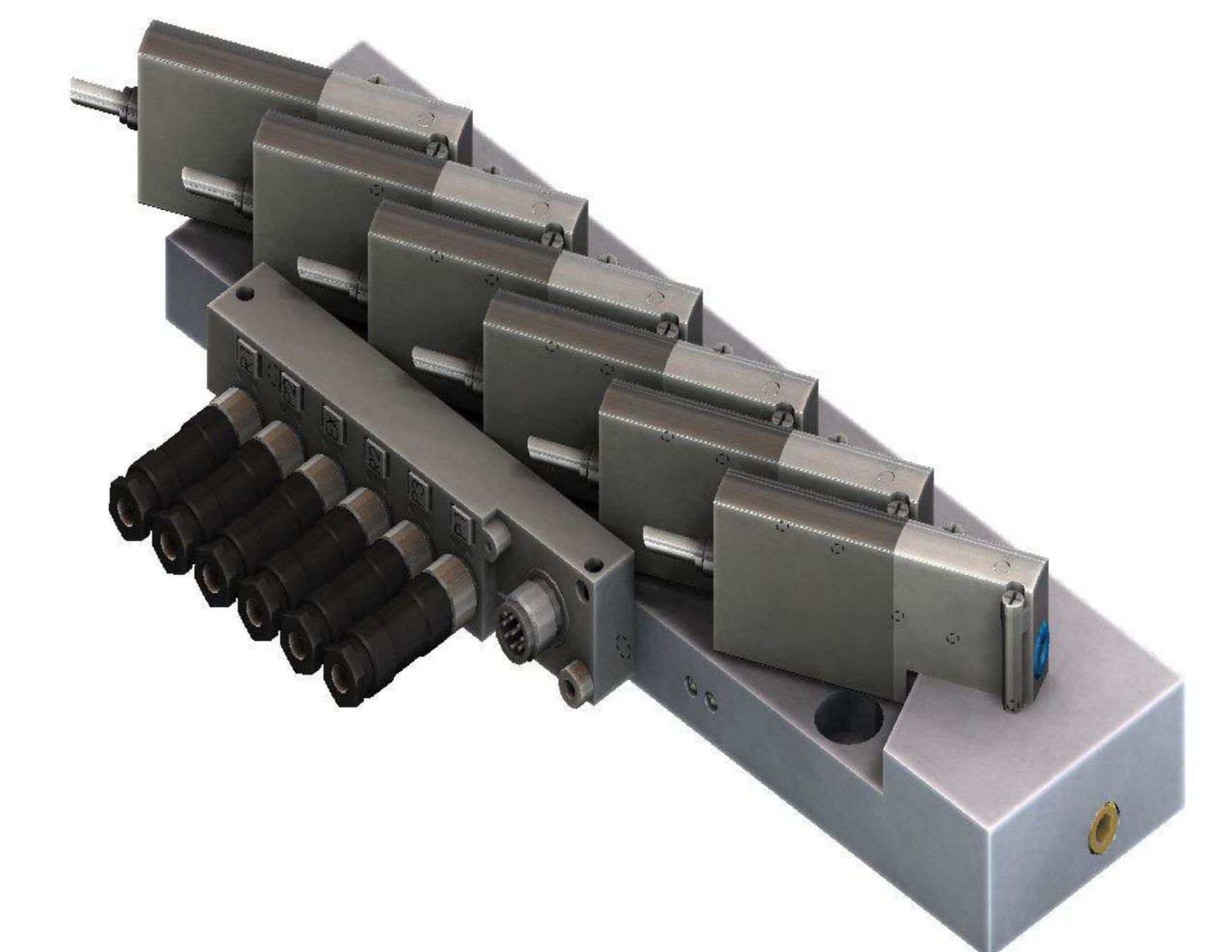

Cover with valve
0002-604-90-30

Rebuilt parts



Rebuilt piston parts
P1/P2 & R
0002-602-90-47

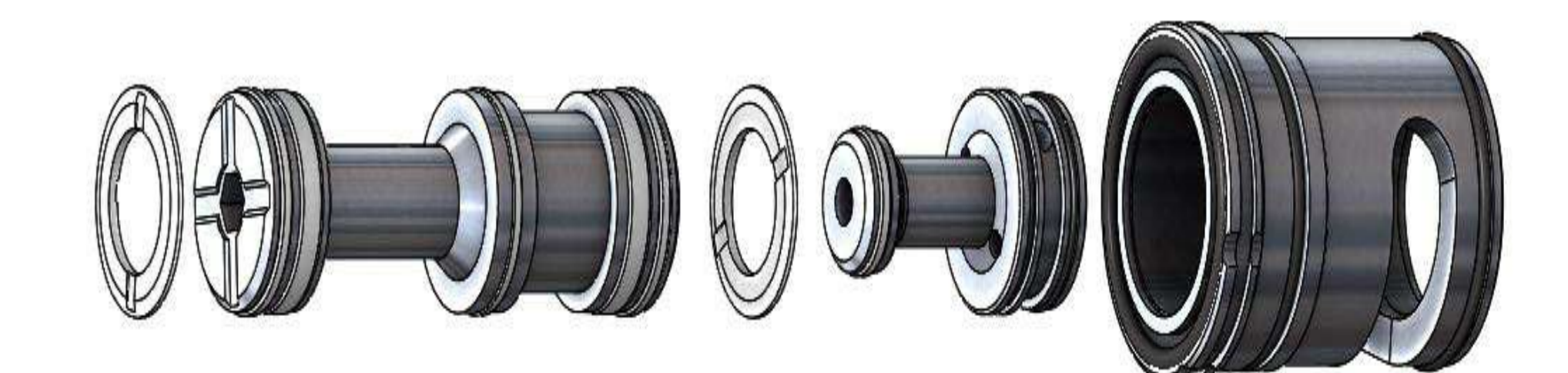

Exhaust rebuilt piston parts
0002-602-90-46

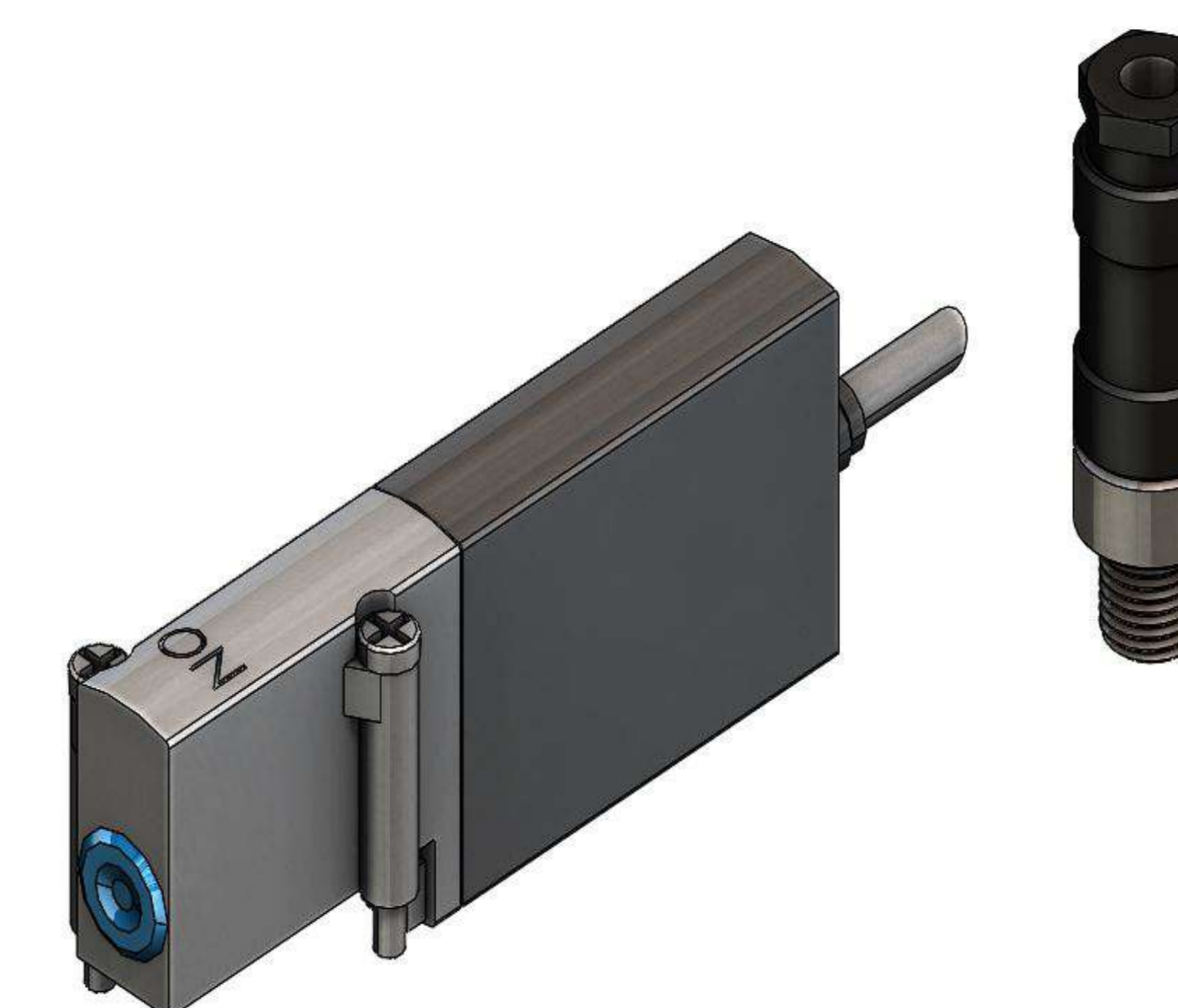

Pilot valve Festo NO
0002-604-90-28

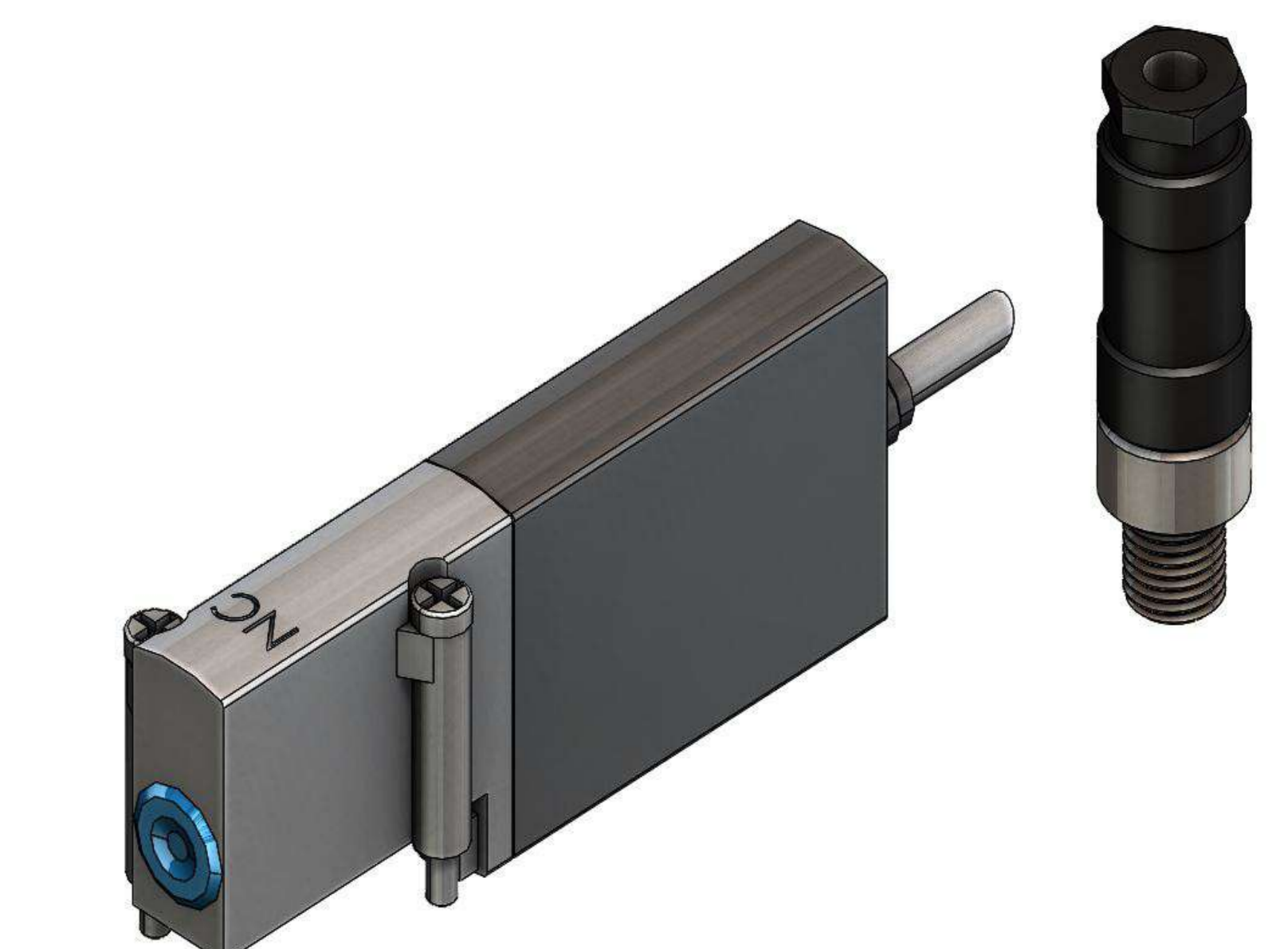

Pilot valve Festo NC
0002-604-90-29

Benefits

Plug & play unit

25 % savings on maintenance kits compare to OEM

UM #	Description	Known OEM number
UMS-01173934401	Matrix blowing block	01173934401

IMPROVED MATRIX BLOWING BLOCK

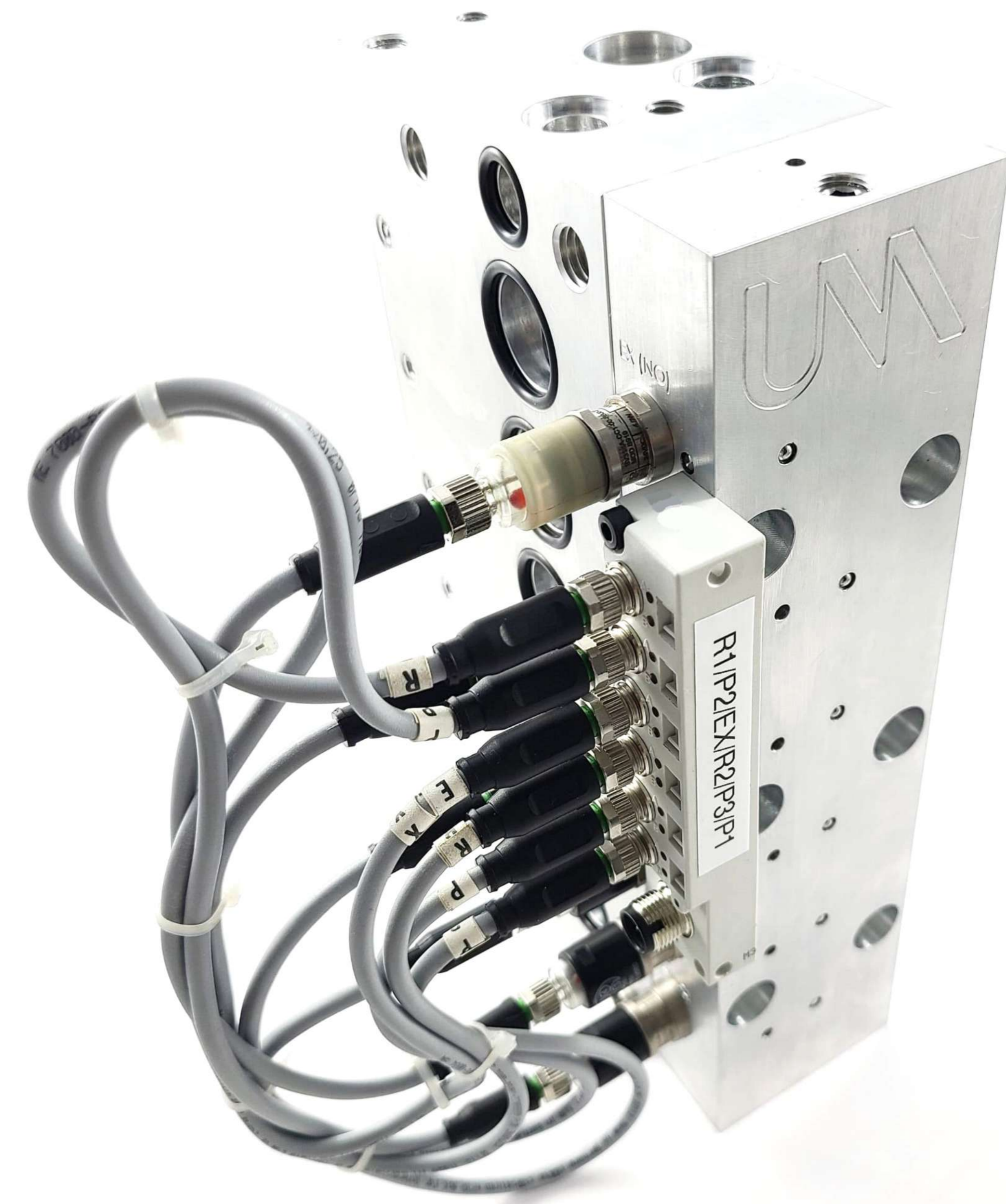

Improved block manifold
0002-604-90-66

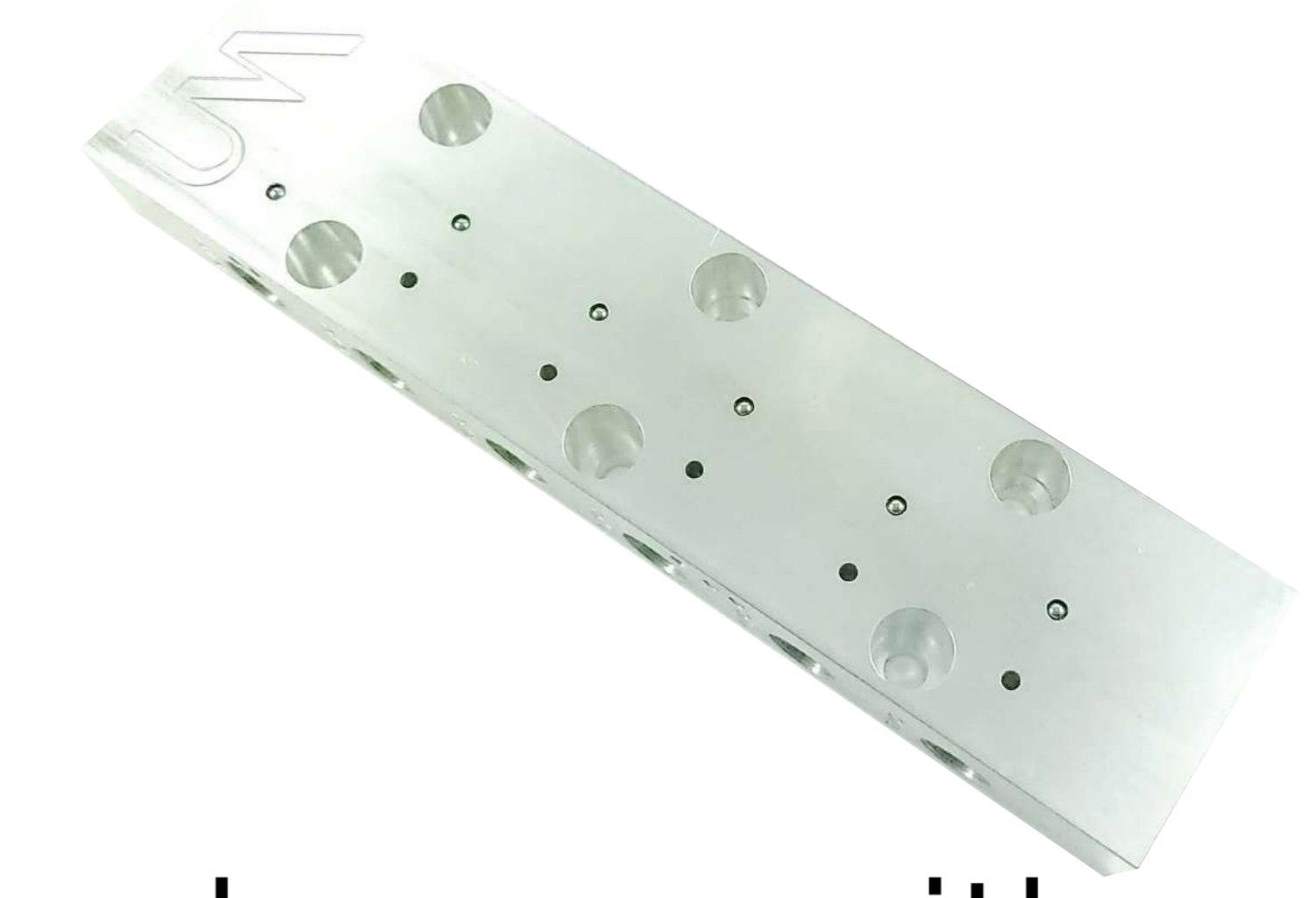

Improved cover without valve
0002-604-90-51

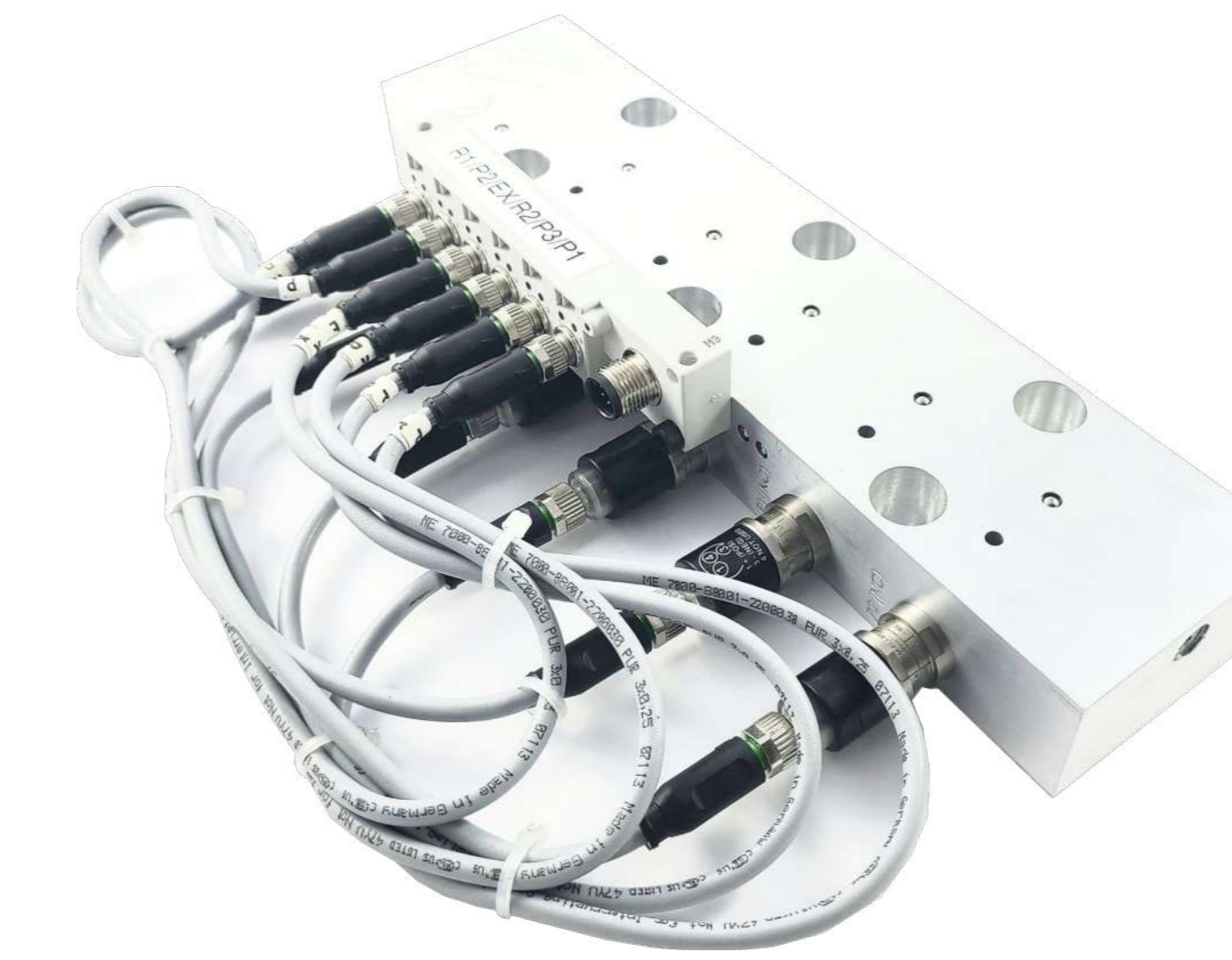

Improved cover with valve
0002-604-90-13



Improved piston maintenance kit (6)
0002-604-90-84



Rebuilt kit piston (EXH)
0002-604-90-71



Rebuilt kit piston (P&R)
0002-604-90-72



Rebuilt kit piston (P1)
0002-604-90-73



Rebuilt kit piston
(4 P&R, 1 EXH, 1 P1)
0002-604-90-74



Vallet bullet mac
3/2 NO, 24V,DC, connector M8
VPB24VDCNO8919



Valve bullet mac
3/2 NF, 24V, DC, connector M8
VPB24VDCNF8918

Rebuilt parts

Benefits

- Mac pilot valves (standard components), no dependence to OEM
- Hardened main block, 35 % more longevity
- 40 % savings on maintenance kits compare to OEM
- Plug & play unit

UM #	Description	Known OEM number
UMS-01173934401M	Improved matrix blowing block (6 pistons)	01173934401

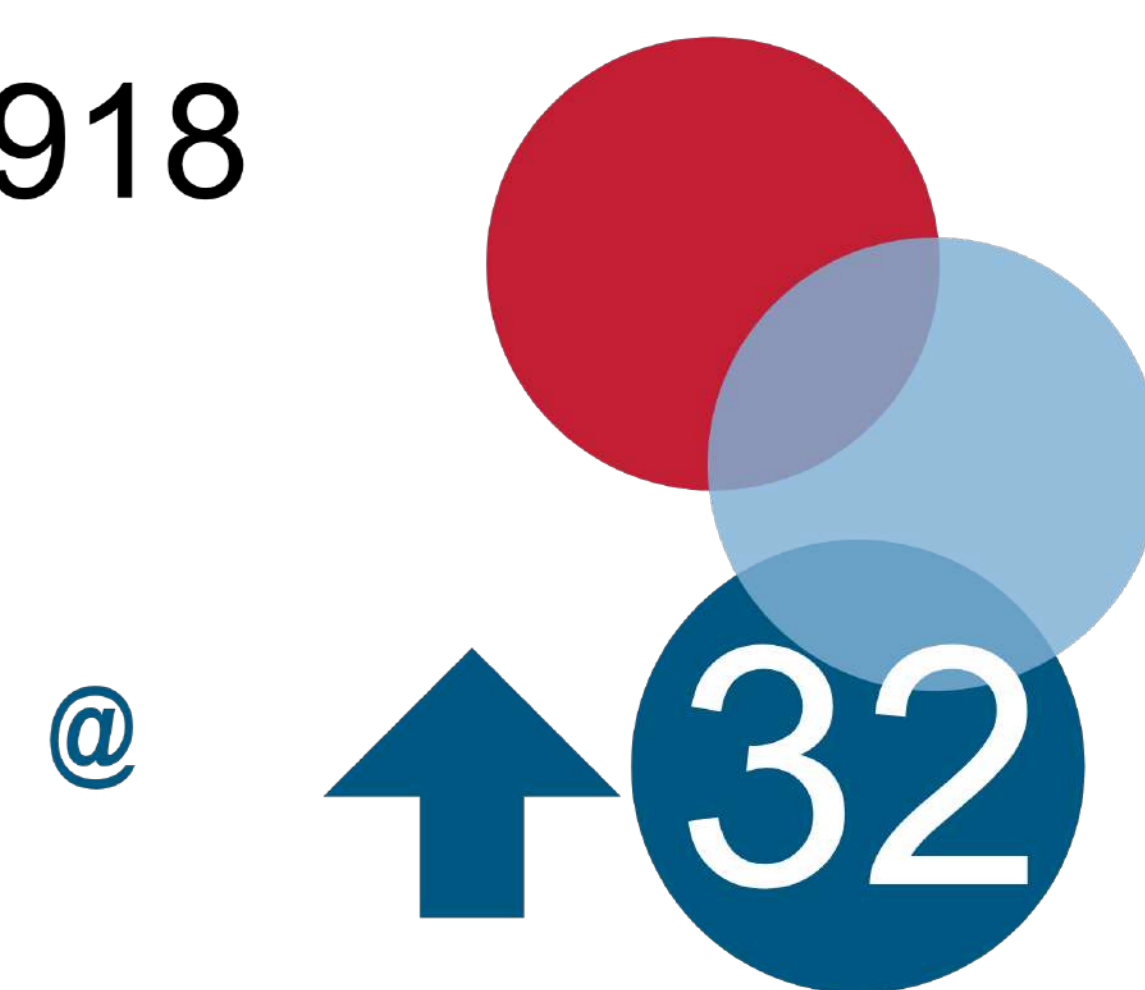

IMPROVED MATRIX BLOWING BLOCK



Benefits

- Mac pilot valves (standard components), no dependence to OEM
- Hardened main block, **35 %** more longevity
- 40 %** savings on maintenance kits compare to OEM
- Plug & play unit

Rebuilt parts

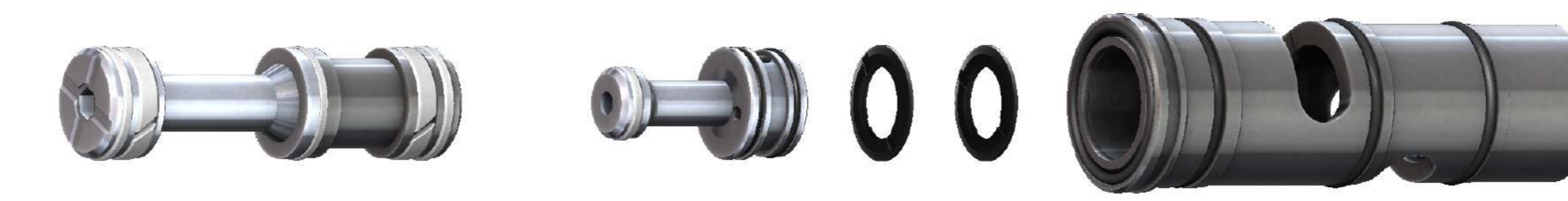

Rebuilt kit piston (EXH)
0002-604-90-71



Rebuilt kit piston (P&R)
0002-604-90-72



Rebuilt kit piston (P1)
0002-604-90-73



Improved complete main body
0002-604-90-76



Rebuilt kit piston
(3 P&R, 1 EXH, 1 P1)
0002-604-90-83



Improved complete main body
for OEM conversion
0002-604-90-82



Improved piston
maintenance kit (5)
0002-604-90-85

UM #	Description	Known OEM number
UMS-01168891301M	Improved matrix blowing block (5 pistons)	01168891301

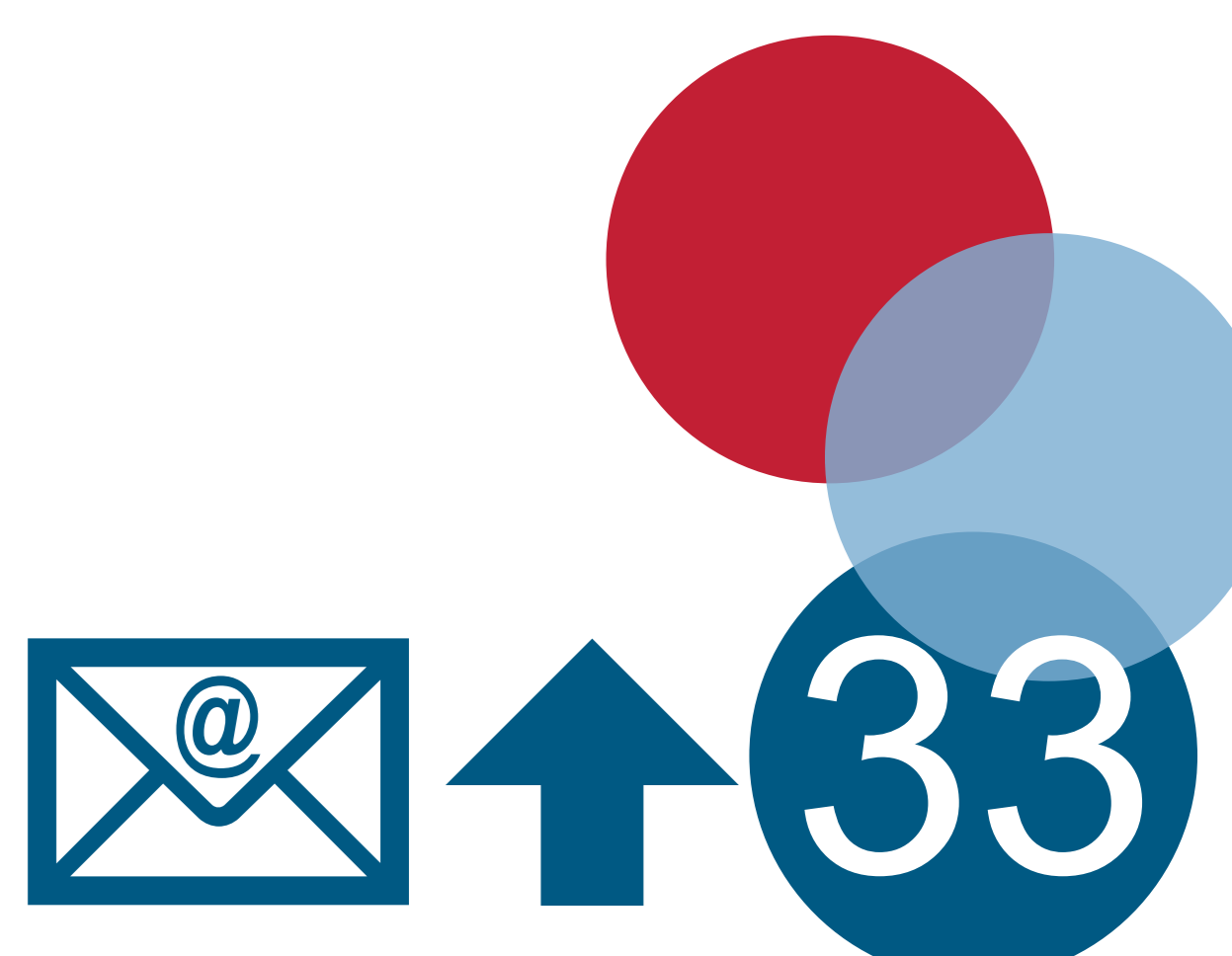

MOLDS



partner with **röders**
TEC

Please fill the form below to confirm the molds you need.

HOW MANY MOLDS ARE NEEDED ?



MOLD DETAILS

Preform drawings

Bottle drawings & 3D

Pictures

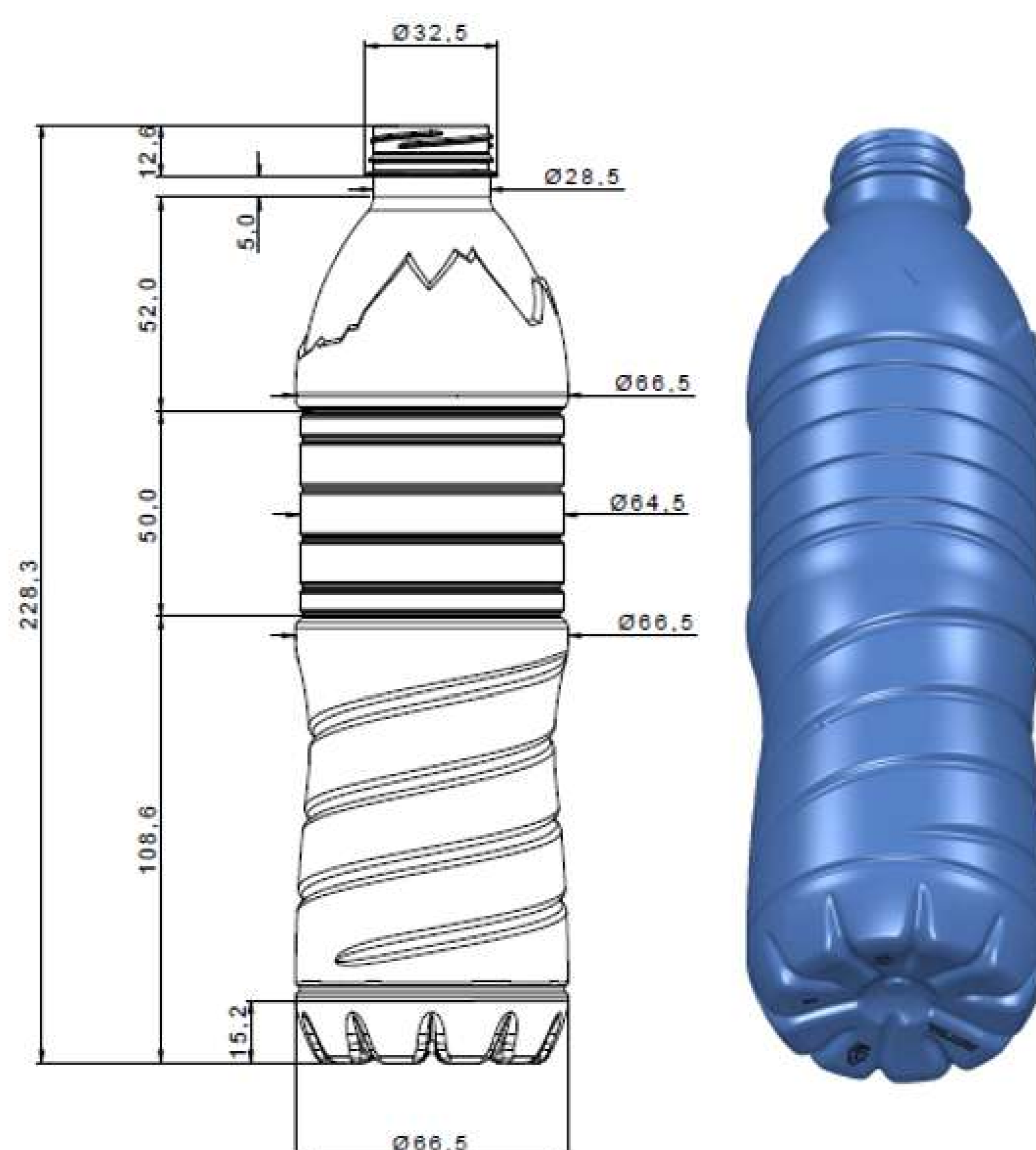
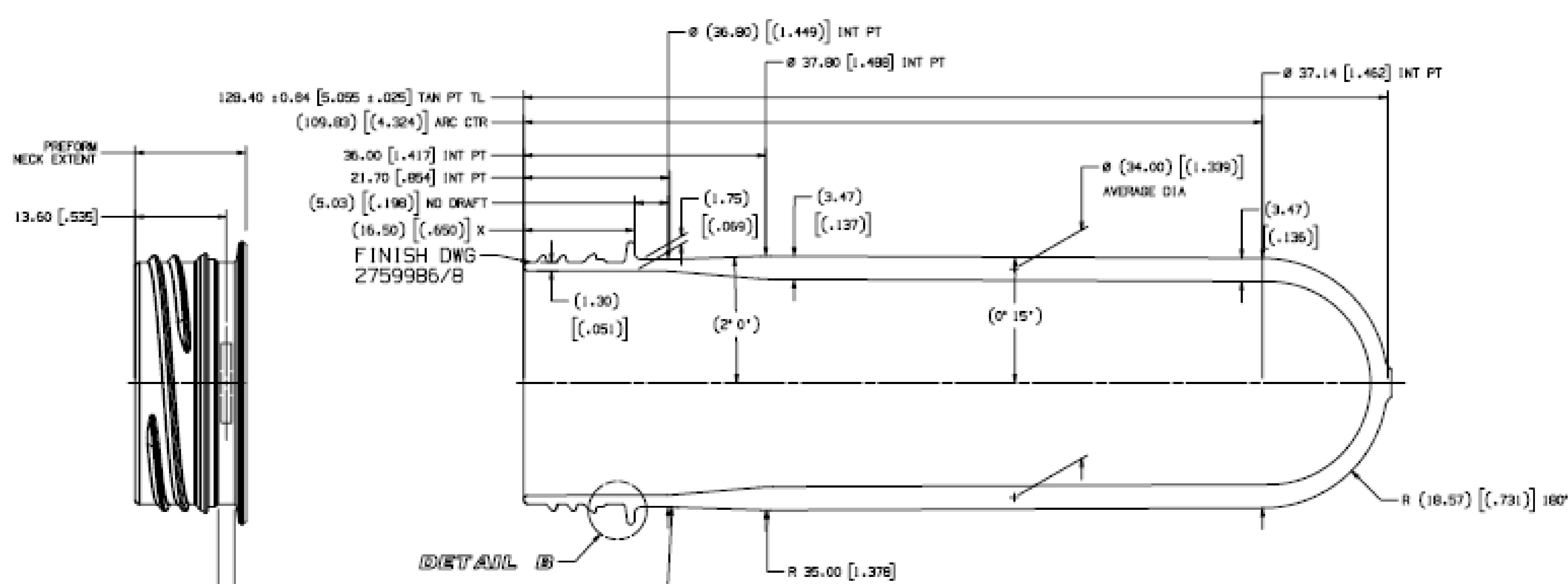

If you need to develop a new bottle, check this box :

For a precise quotation, please fill the technical mold information below :

[PDF - CLICK HERE](#)

MOLD HANGER



UMS-01117166301



UMS-01117166401

Benefits

Better aluminum grade than OEM
Stainless steel available

UM #	Description	Known OEM number
UMS-01071553508M	Mold shell right	01071553508
UMS-01071553608M	Mold shell left	01071553608
UMS-01117166301	Mold shell right ass'y	01117166301
UMS-01117166401	Mold shell left ass'y	01117166401

REBUILT MOLD HANGER



UMS-01071553608R

Benefits

- Better aluminum grade than OEM
- Maintenance kit available
- Easy to rebuilt in house
- Savings
- Stainless steel channel, interchangeable, no corrosion
- Both side, compensation and none compensation available

UM #	Description	Known OEM number
UMS-01071553508R	Rebuilt right shell support	01071553508
UMS-01071553608R	Rebuilt left shell support	01071553608

PNEUMATIC MOLD BASE



Benefits

OEM equivalent quality

Components always kept in stock

Available for S2 and universal blow molders

Rebuild kit available and kept in stock

Rebuilt parts



Pneumatic mold base support rebuilt parts
UMS-01124526305KR

UM #	Description	Known OEM number
UMS-01142329603	Pneumatic mold base	01142329603
UMS-01124451005	Pneumatic mold base support	01124451005
UMS-01124526305	Pneumatic mold base support	01124526305

ROTARY UNION S1



Benefits

Rebuilt as a new unit

Chrome and surface fully rebuilt

Fully inspected unit with pressure tes

UM #	Description	Known OEM number
UMS-00000020537R	SBO10 air rotary union rebuilt	LH020537
UMS-99000406659R	S1 SB04 oil rotary union rebuilt / 10 water	99000406659 LH023525 LH023286
UMS-99000069227R	S1 SB016 oil rotary union rebuilt / 24 water	99000069227 LH023526 LH023268
UMS-99000401280R	S1 SB0 24 oil rotary union rebuilt / 48 water	99000401280 LH023193

ROTARY UNION S2



S2 water rotary union



S2 air rotary union



Benefits

Rebuilt as a new unit

Chrome and surface fully rebuilt

Fully inspected unit with pressure test

UM #	Description	Known OEM number
UMS-99000411427R	Rebuilt S2 air rotary union	99000016461 99000451821 99000451822 01123543202 01069652603
UMS-01002131803R	Rebuilt S2 water rotary union	

ROTARY UNION UNIVERSAL

Benefits

Rebuilt as a new unit

Chrome and surface fully rebuilt

Fully inspected unit with pressure test

UM #	Description	Known OEM number
UMS-01131860801	Air rotary union rebuilt	01131860801
UMS-01126808301	SBO8 air rotary union rebuilt	01126808301
UMS-126915	Water rotary union universal	126915 01130697201

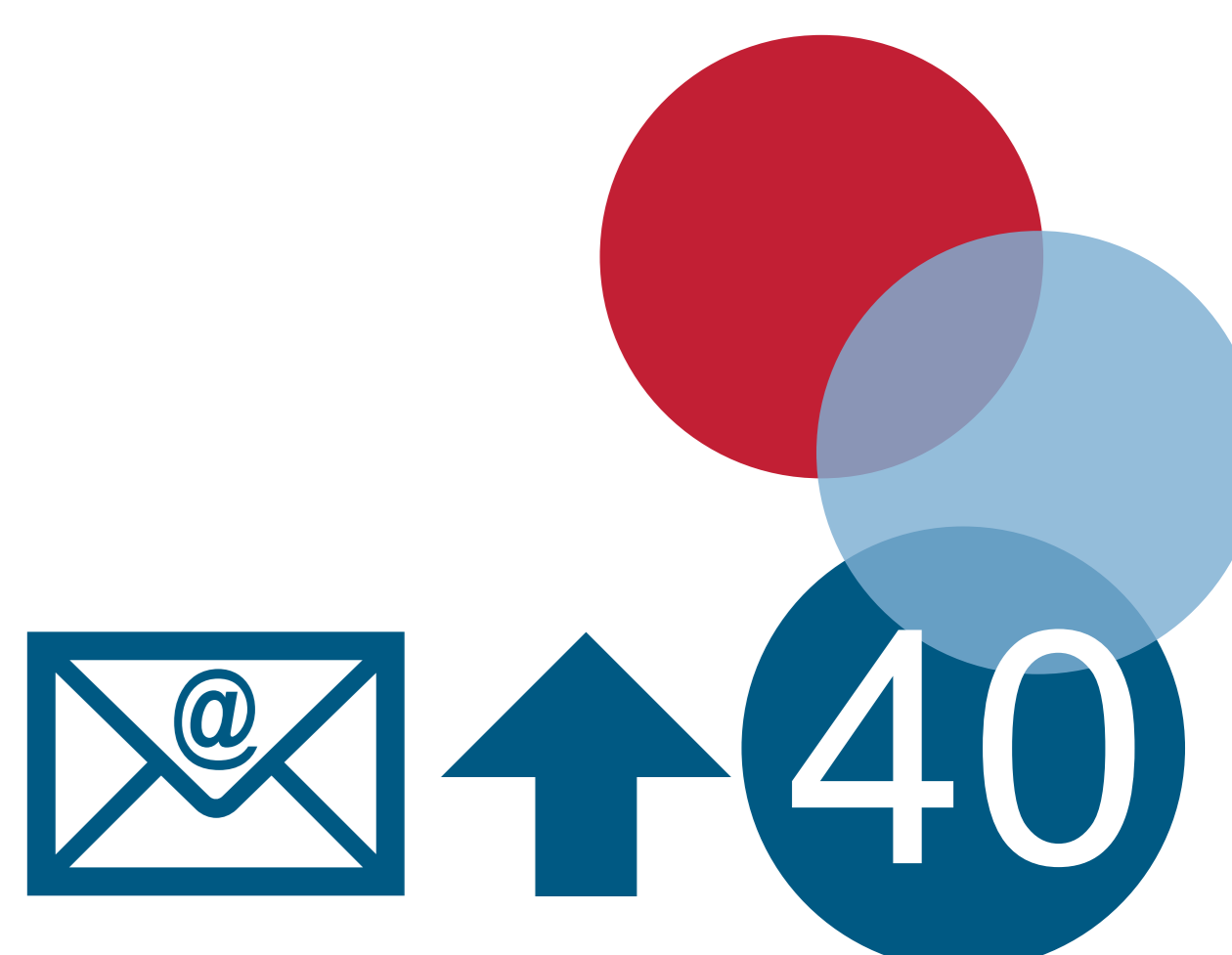

REBUILT ROTARY UNION



Benefits

- Rebuilt as a new unit
- Chrome and surface fully rebuilt
- Fully inspected unit with pressure test

Rebuilt parts

Water rotary rebuilt parts
SBO 16/18/20
UMS-01002131803KR

Water rotary seal rebuilt parts
SBO 16/18/20
UMS-01002131803KR2

UM #	Description	Known OEM number
UMS-01002131803	S2 SBO16-18-20 water rotary union rebuild	01002131803

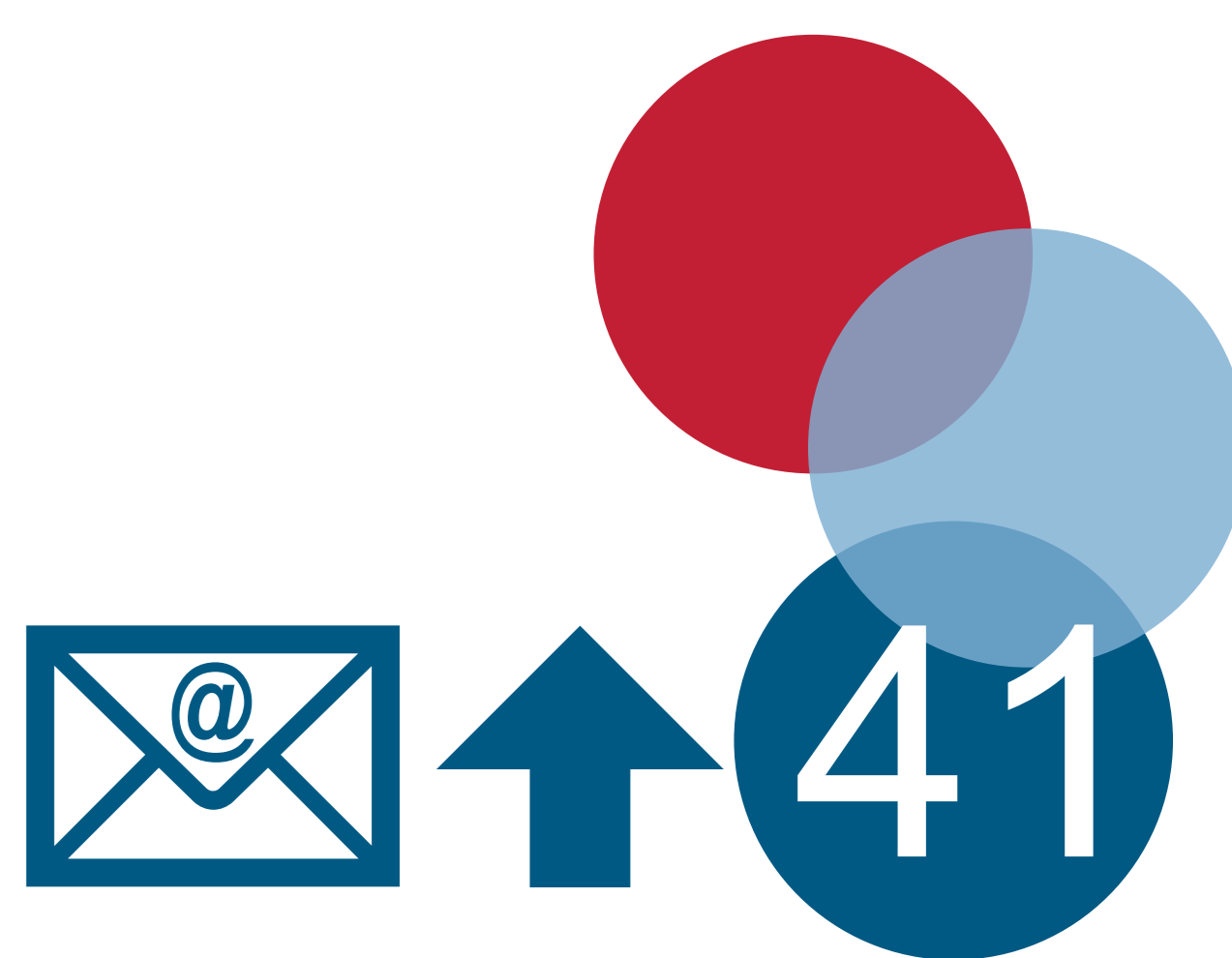

SHOCK ABSORBER & STOPPING TRUST



Shock absorber

Benefits

Direct replacement

Same quality as OEM

UM #	Description	Known OEM number
UMS-00000101736	Shock absorber PRO MC	00000101736
UMS-01005347402	Shock absorber 06 14 L DO SB	01005347402
UMS-99000426369	Shock absorber	99000426369
UMS-01140320901	Shock absorber SP21899	01140320901
UMS-00000106825	Shock absorber SP21899	00000106825
UMS-00000117735	Shock absorber SP22363S	00000117735
UMS-01140329801	Shock absorber SP23601	01140329801
UMS-01073679102	Stopping trust	01073679102

STRETCH ROD CLAMP



S1



Universal



S2 heat set DC



S2 improved



S2 cold set



S2 heat set



S2 cold set DC



S1

Retainer plate top
0002-601-62-03



Universal

Retainer plate top
UMS-01128631001



Retainer bottom plate
0002-601-62-04



Retainer plate bottom
UMS-01124294903



Improved stretch rod clamp (cold set)
UMS-01069471605M



Stretch rod clamp
0002-005-02-20



Plunger
0002-005-02-35



Plunger
0002-005-02-25

Standard components

Benefits

Better longevity (3 times OEM)

Better plunger components to avoid any locking problem

All components harder compare to OEM

UM #	Description	Known OEM number
0002-601-62-01	S1 stretch rod clamp ass'y	
0002-602-62-20	S2 improved stretch rod clamp	
0002-005-03-11	S2 heat set DC stretch rod clamp ass'y	
0002-005-02-32	S2 stretch rod camp ass'y (heat set)	
0002-005-03-00	S2 cold set DC stretch rod clamp ass'y	
0002-005-02-38	S2 stretch rod clamp ass'y (cold set)	
0002-005-02-17	Universal stretch rod clamp ass'y	

STRETCH ROD CLAMP

Standard components

S2 Heat set DC

You must order each item twice



Dual retainer plate top
UMS-733113



Dual retainer plate top
UMS-739241



Stretch rod (heat set)
UMS-729281M



DC plunger
0002-005-03-07

S2 Improved



Retaining plate
0002-602-62-23



Sliding plate
0002-602-62-22



Stretch rod (heat set)
UMS-729281M

Plunger assy
0002-602-62-24

S2 cold set



Retainer plate top
UMS-723367M



Retainer plate bottom
UMS-727970M



Improved stretch rod
clamp (cold set)
UMS-01069471605M



Plunger
0002-005-02-35

S2 Heat set



Retainer plate top
UMS-723367M



Retainer plate bottom
UMS-727970M



Stretch rod (heat set)
UMS-729281M



Plunger
0002-005-02-35

S2 cold set DC

You must order each item twice



Dual thrust plate
UMS-733133



Dual retainer plate top
UMS-739241



Improved stretch rod
clamp (cold set)
UMS-01069471605M



DC plunger
0002-005-03-07

STRETCH ROD CYLINDER S2



Benefits

- Drop-in replacement
- Insensitivity to contamination and pressure variations
- Repeatable response time
- High flow capacity of the valve to ensure fast retract or the stretching cam
- Cost saving: increased production, reduced labor cost and fewer replacement parts
- ISO compatible with MAC pilot valves

Standard components



Stretch rod cylinder maintenance parts
UMS-STRETCHRODCYL-S2-KR

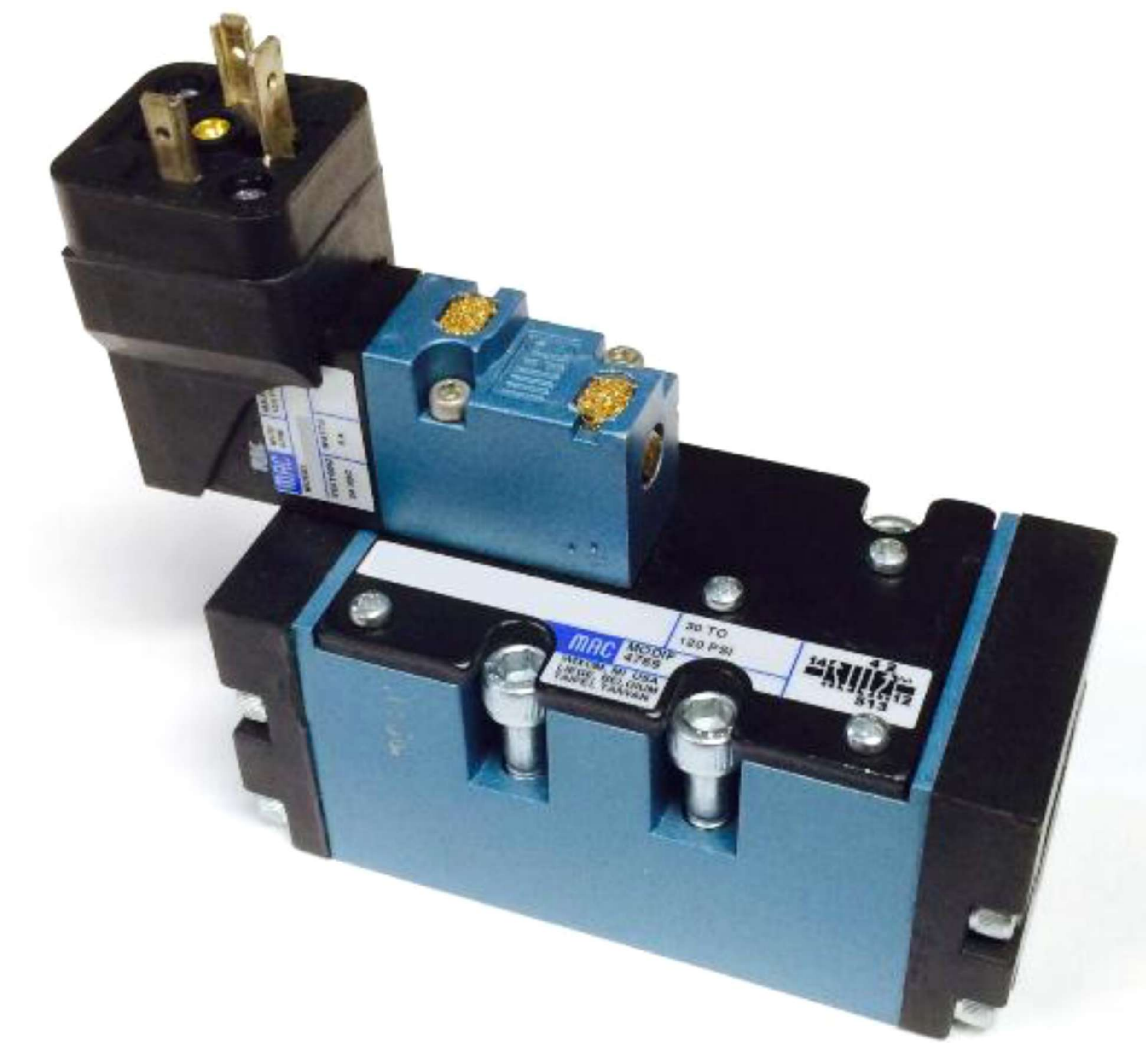

Stretch rod cylinder pilot valve
UMS-0000053063M

UM #	Description	Known OEM number
UMS-STRETCHRODCYL-S2	S2 stretch rod cylinder	01119806601 to 04 01122236301 to 05

TRANSMISSION BELT

We can have all transmission belts, just ask us



UMS-00000109985



UMS-00000109987

Benefits

Direct replacement

Same quality as OEM

Cost saving

UM #	Description	Known OEM number	UM #	Description	Known OEM number
UMS-0000094107	Transmission belt AT20/3200 BFX SD	0000094107	UMS-0000092162	Transmission belt 32 AT10/1880 SYN SD	0000092162
UMS-00000113587	Transmission belt 25 AT10/1250 BFX DL	00000113587	UMS-00000165791	Transmission belt 32 AT10/1900 BFX SD	00000165791
UMS-00000144775	Transmission belt 25 AT10/1270 BFX D	00000144775	UMS-00000122220	Transmission belt 32 AT10/2650 BFX DL	00000122220
UMS-0000092147	Transmission belt 25 T10/1800 BFX SD	0000092147	UMS-00000108849	Transmission belt 50 AT15	00000108849
UMS-0000093167	Transmission belt 25 AT10/1800 SYN SD	0000093167	UMS-0000093975	Transmission belt 50 AT10/1310 BFX SD	0000093975
UMS-0000093211	Transmission belt 25 AT10/1850 SYN SD synchroflex	0000093211	UMS-0000092203	Transmission belt 50 T10/1670 BFX SD	0000092203
UMS-0000093683	Transmission belt 25 AT10/1900 BFX SD	0000093683	UMS-0000091514	Transmission belt 50 T10/1750 SYN SD	0000091514
UMS-00000135903	Transmission belt 25 ATS10/2240 BFX DL SPL	00000135903	UMS-00000117124	Transmission belt 50 AT15/1950 BFX SD	00000117124
UMS-0000093252	Transmission belt 32 AT10/1150SYN	0000093252	UMS-00000109985	Transmission belt 50 AT15/1995 BFX SD	00000109985
UMS-0000093985	Transmission belt 32 AT10/1400 SYN	0000093985	UMS-0000093884	Transmission belt 50 AT20/2120 BFX SD	0000093884
UMS-00000146380	Transmission belt 32 AT10/1480	00000146380	UMS-0000093974	Transmission belt 50 AT10/2120 BFX DL HF 271	0000093974
UMS-0000092879	Transmission belt 32 AT10 / 1740 BFX SD	0000092879	UMS-0000093973	Transmission belt 50 AT20/2140 BFX SD 241	0000093973

TRANSMISSION BELT

We can have all transmission belts, just ask us

UM #	Description	Known OEM number	UM #	Description	Known OEM number
UMS-00000119925	Transmission belt 50 AT10/2310 BFX DL	00000119925	UMS-00000092164	Transmission belt 50 AT20/4500 BFX SD	00000092164
UMS-00000117120	Transmission belt 50 AT10/2500 BFX	00000117120	UMS-00000216032	Transmission belt 50 AT15/4515 BFX SD	00000216032
UMS-00000092504	Transmission belt 50 AT20/2500 BFX SD	00000092504	UMS-00000108848	Transmission belt 75 AT15	00000108848
UMS-00000117121	Transmission belt 50 AT10/2550 BFX SD	00000117121	UMS-00000118414	Transmission belt 75 AT15	00000118414
UMS-00000094105	Transmission belt 50 AT20/2580 BFX SD	00000094105	UMS-00000117122	Transmission belt 75 AT15/2415 BFX SD	00000117122
UMS-00000110043	Transmission belt 50 AT15/2655 BFX SD	00000110043	UMS-00000109987	Transmission belt 75 AT15/2610 BFX SD	00000109987
UMS-00000094614	Transmission belt 50 AT10/2700 BFX DL 260	00000094614	UMS-00000093997	Transmission belt 75 AT20/2660 BFX SD	00000093997
UMS-00000094108	Transmission belt 50 AT10/2800 BFX DL	00000094108	UMS-00000117123	Transmission belt 75 AT15/2760 BFX SD	00000117123
UMS-00000182046	Transmission belt 50 AT15/2940 BFX SD	00000182046	UMS-00000109986	Transmission belt 75 AT15/2955 BFX SD	00000109986
UMS-00000093851	Transmission belt 50 AT20/3020 BFX SD	00000093851	UMS-00000092931	Transmission belt 75 AT20/3000	00000092931
UMS-00000108844	Transmission belt 50 AT 15/3030 BFX SD	00000108844	UMS-00000094106	Transmission belt 75 AT20/3320 BFX SD	00000094106
UMS-00000092163	Transmission belt 50 AT20/3140 BFX SD	00000092163	UMS-00000216033	Transmission belt 75 AT15/3390 BFX SD	00000216033
UMS-00000108843	Transmission belt 50 AT15/3180 BFX	00000108843	UMS-00000091376	Transmission belt synchroflex	00000091376
UMS-00000094064	Transmission belt 50 AT20/3460 BFX SD	00000094064	UMS-00000091502	Transmission belt synchroflex	00000091502
UMS-00000092206	Transmission belt 50 AT20/3560 BFX	00000092206	UMS-00000109870	Transmission belt synchroflex	00000109870
UMS-00000195264	Transmission belt 50 AT15/3600 BFX SD	00000195264	UMS-00000156006	Transmission belt synchroflex	00000156006

UNIVERSAL STATION

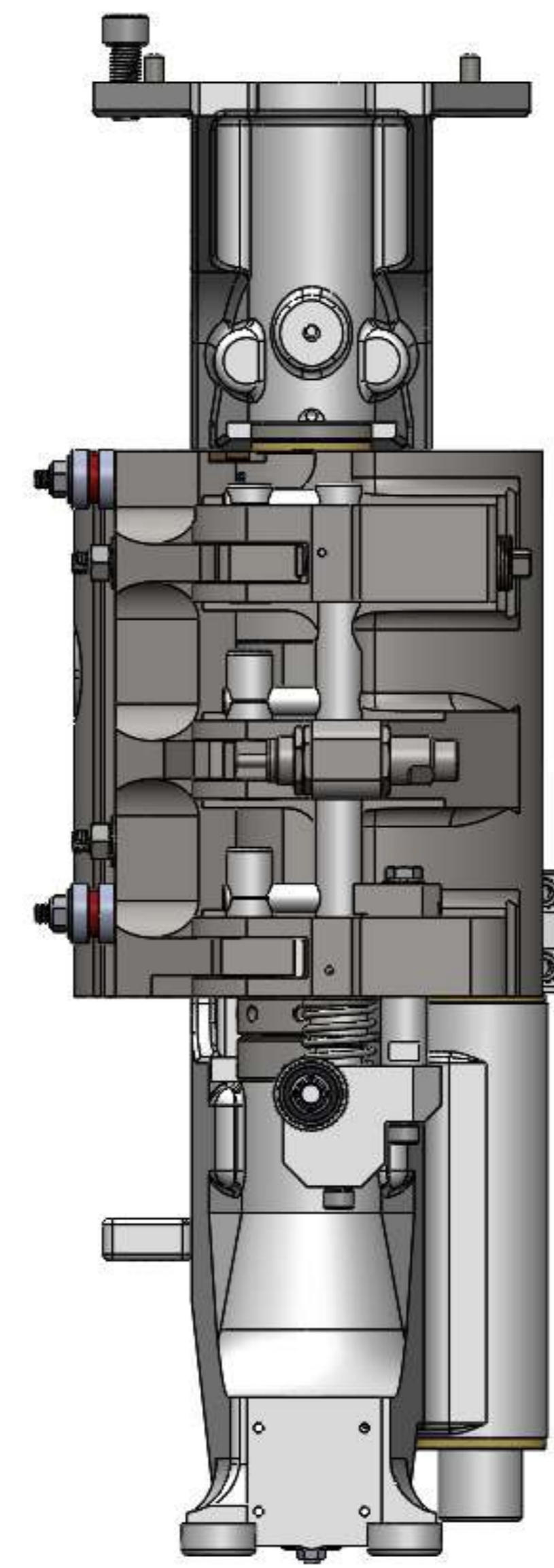
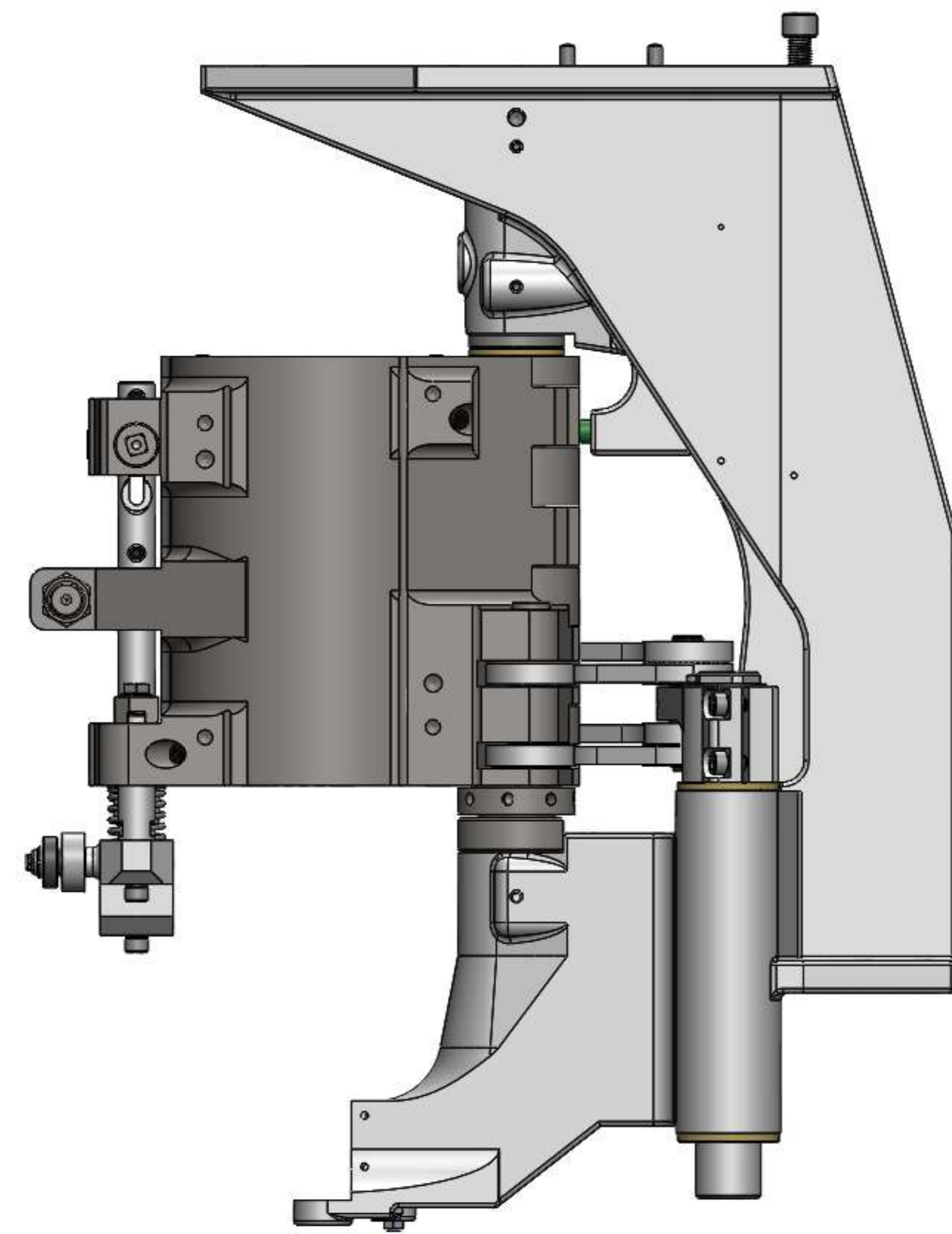
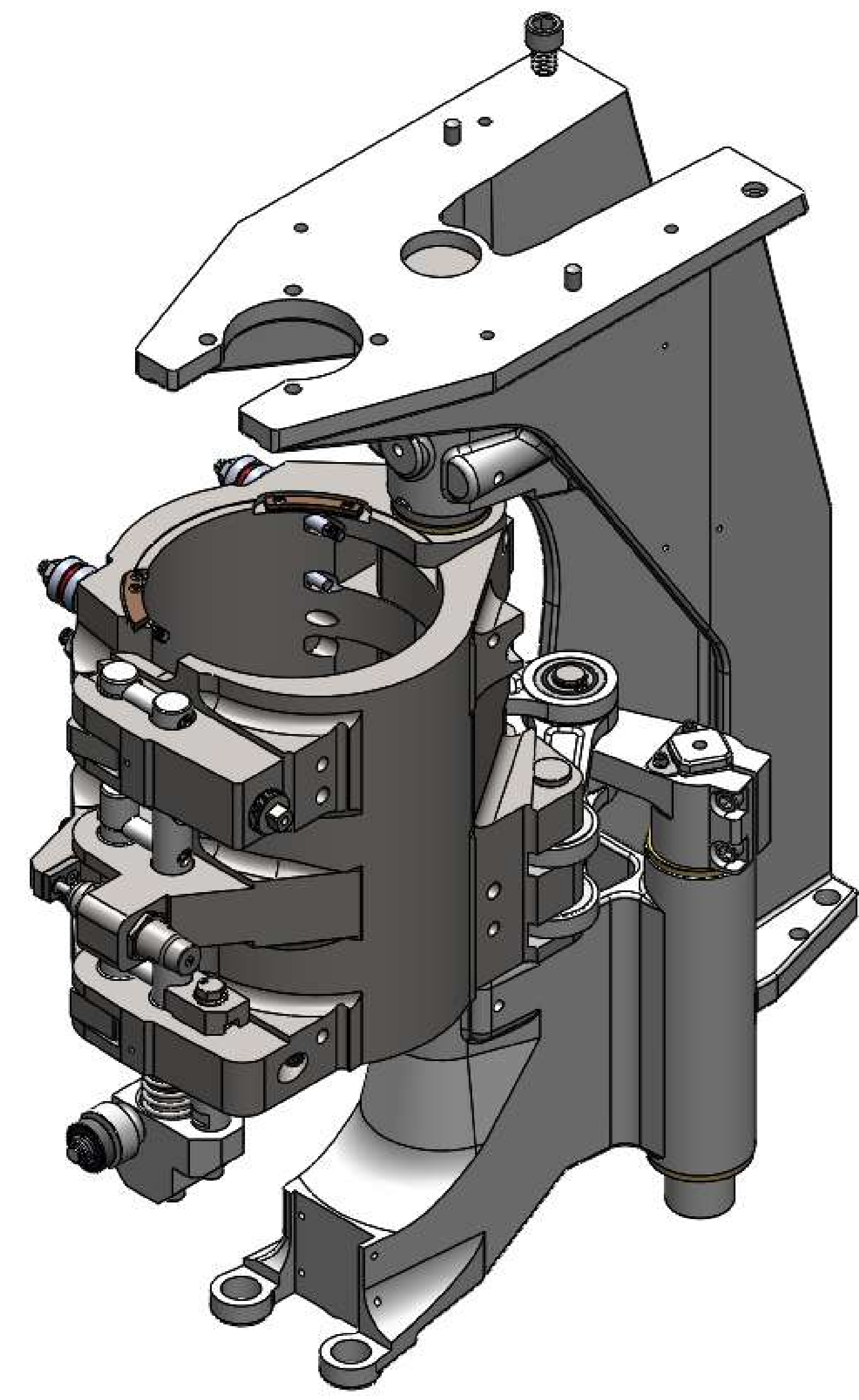

Benefits

Direct replacement
Same quality as OEM

Standard components



Compensation bumper heat set
UMS-00000002248



Roller (F55169402)
UMS-00000116500



Shock absorber SP 22363
UMS-00000117735



Shock absorber thrust
UMS-01069215704



Axe
UMS-01060703400



Axe
UMS-01062198300



Peelable shim
UMS-01065055600

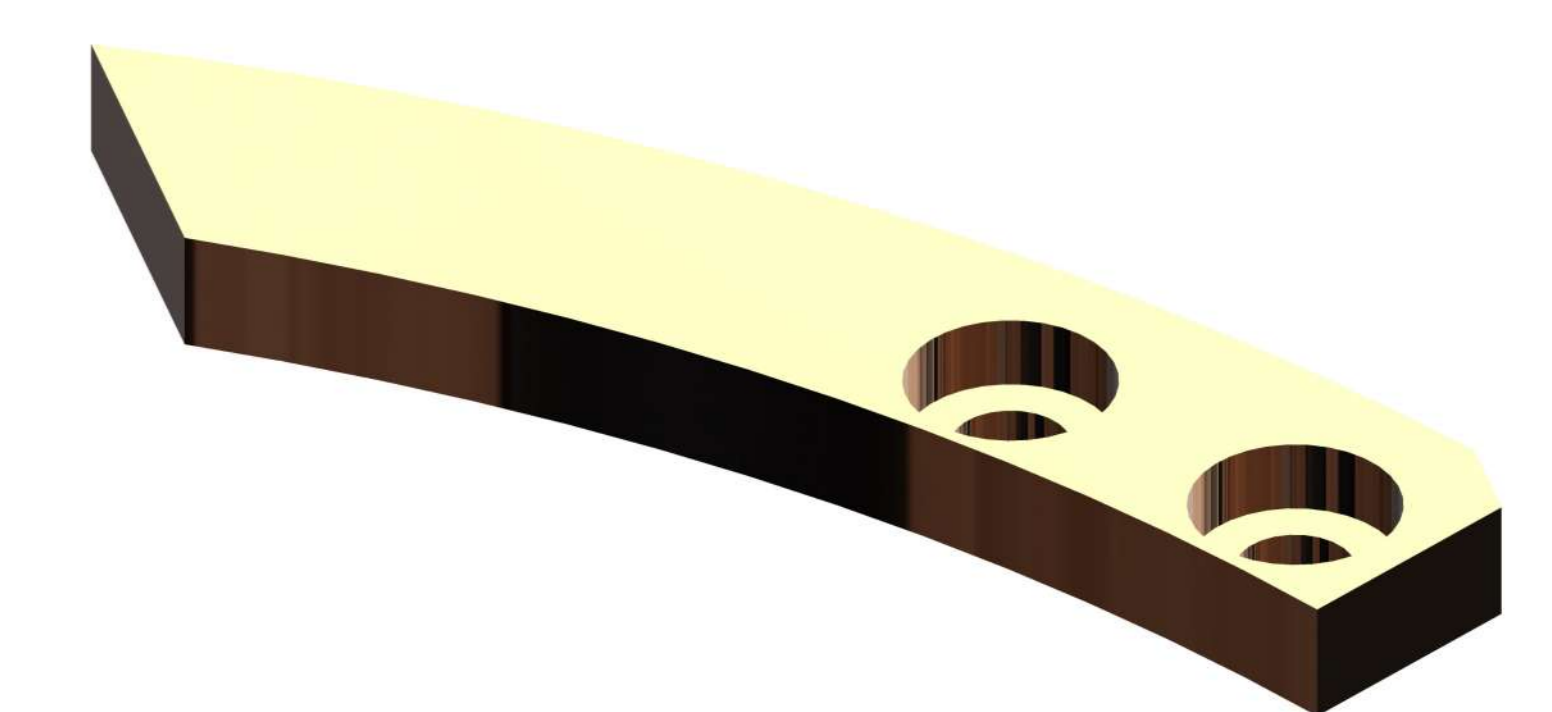

Front slide
UMS-01069215303

UNIVERSAL STATION

Standard components



Lock thrust
UMS-01069215803



Stroke pin
UMS-01071552801



Peelable shim
UMS-01071553801

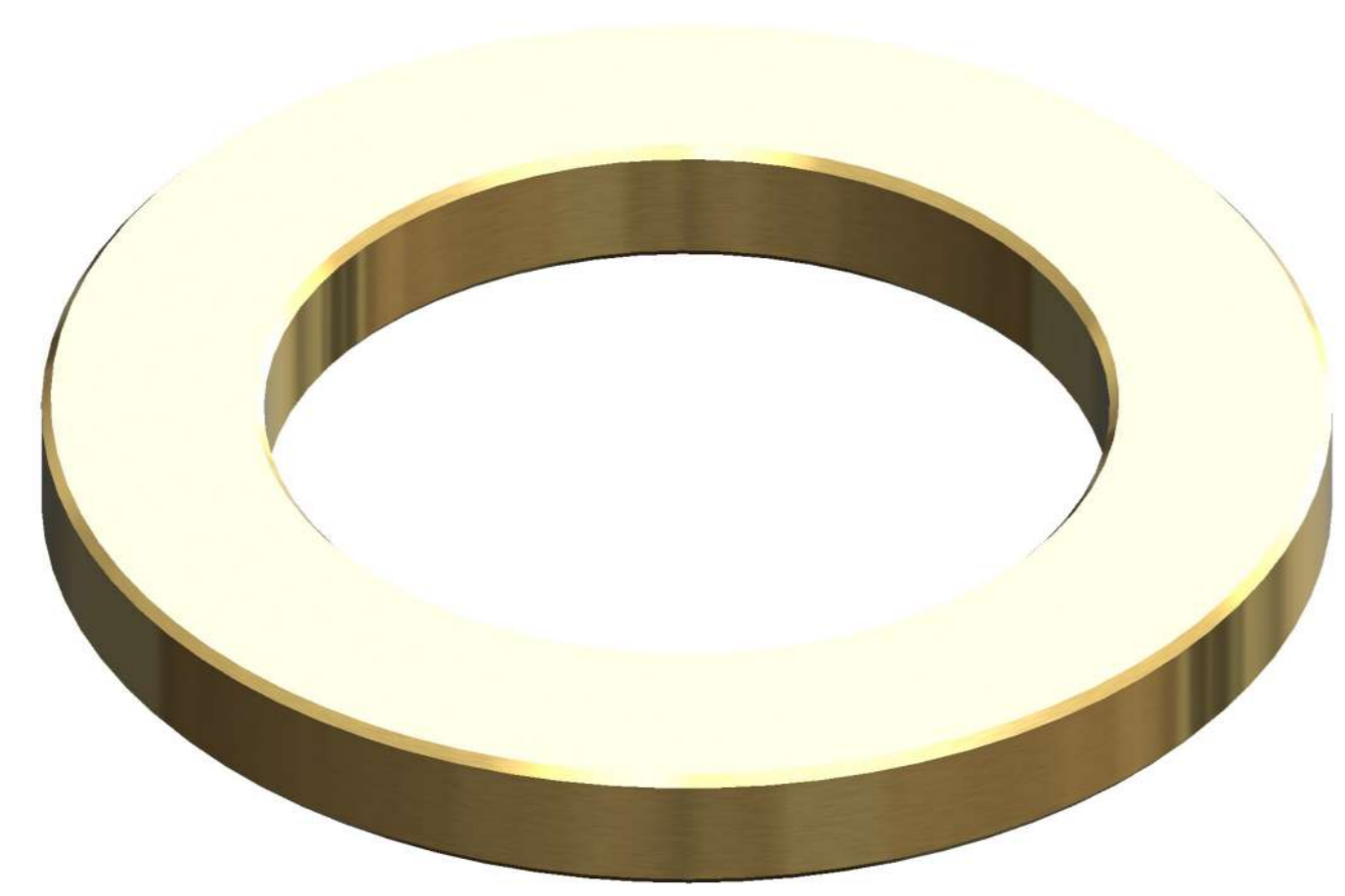

Washer
UMS-01069633002



Sheath
UMS-01073307402

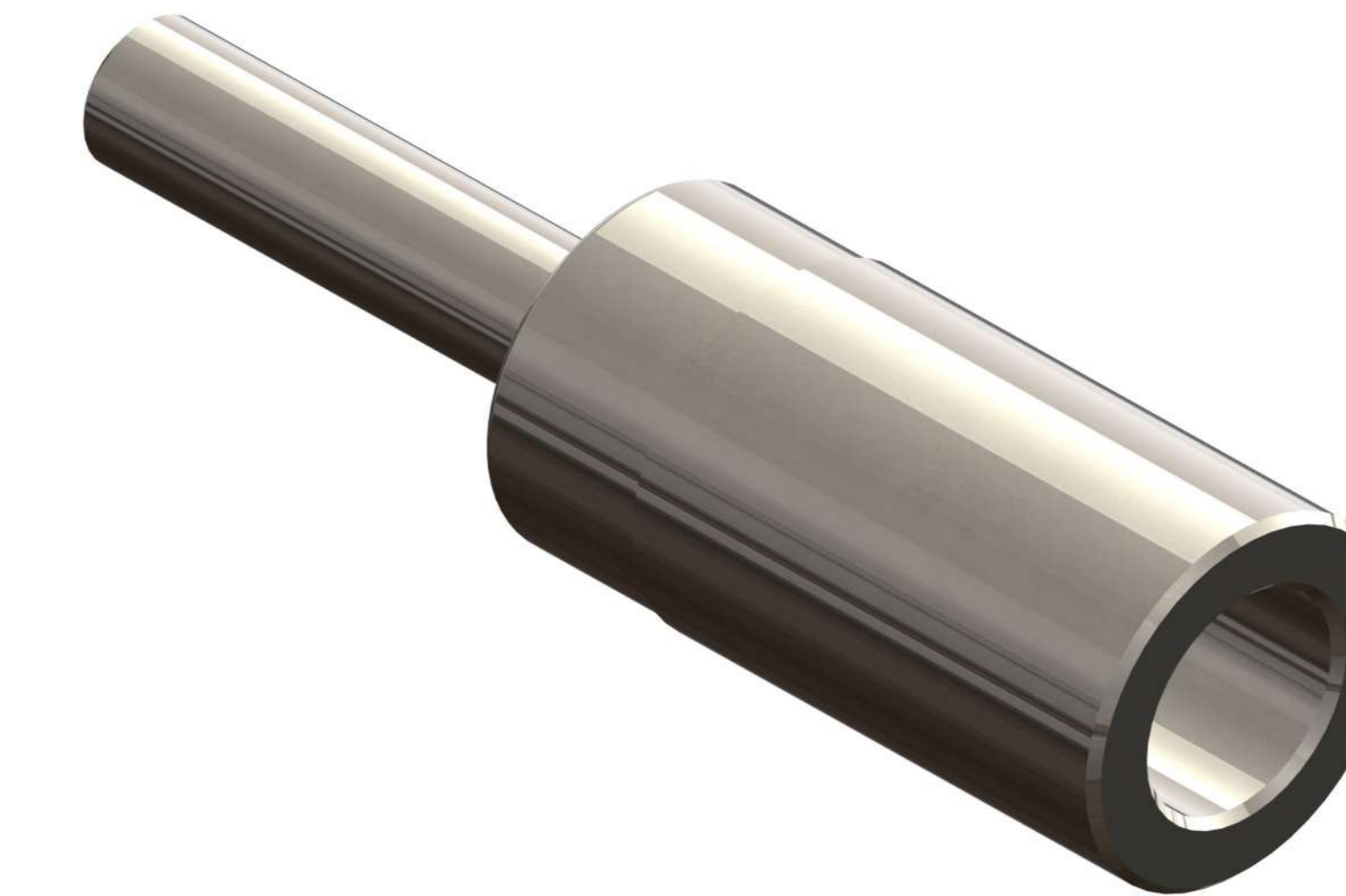

Locking pin
UMS-01073335005



Screw
UMS-01071552202

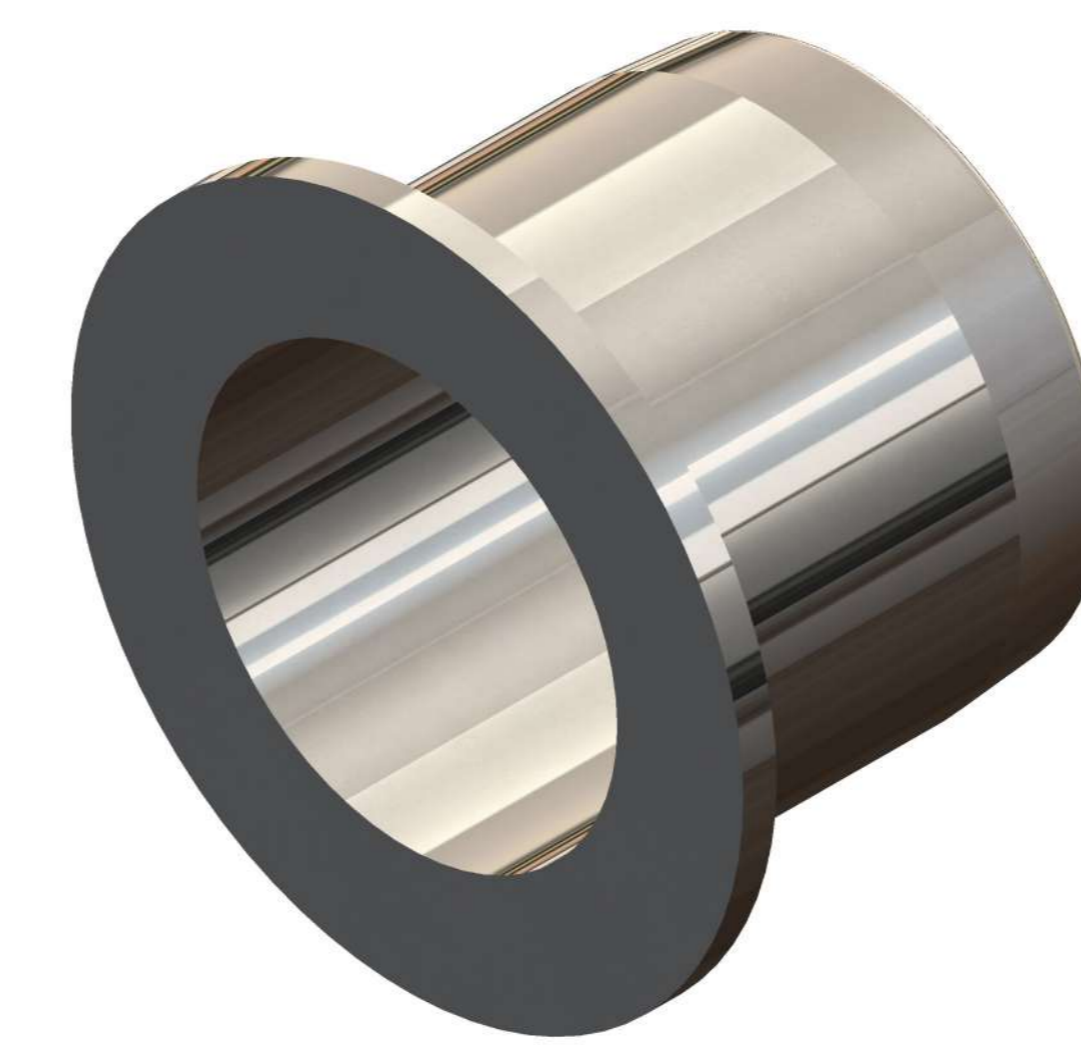

Upper guide ring
UMS-01073332502

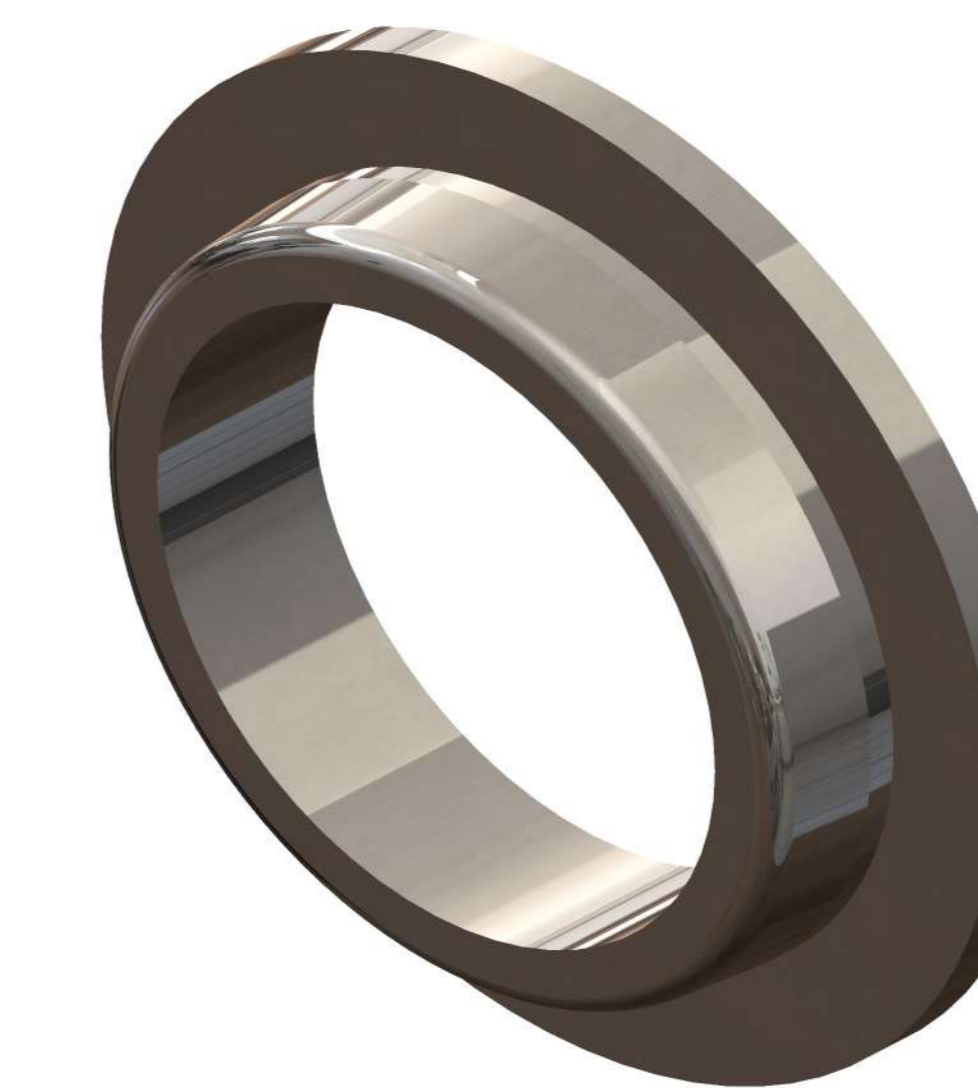

Lower guide ring
UMS-01073332601



Bearing ring 25x30x10
UMS-01071552702

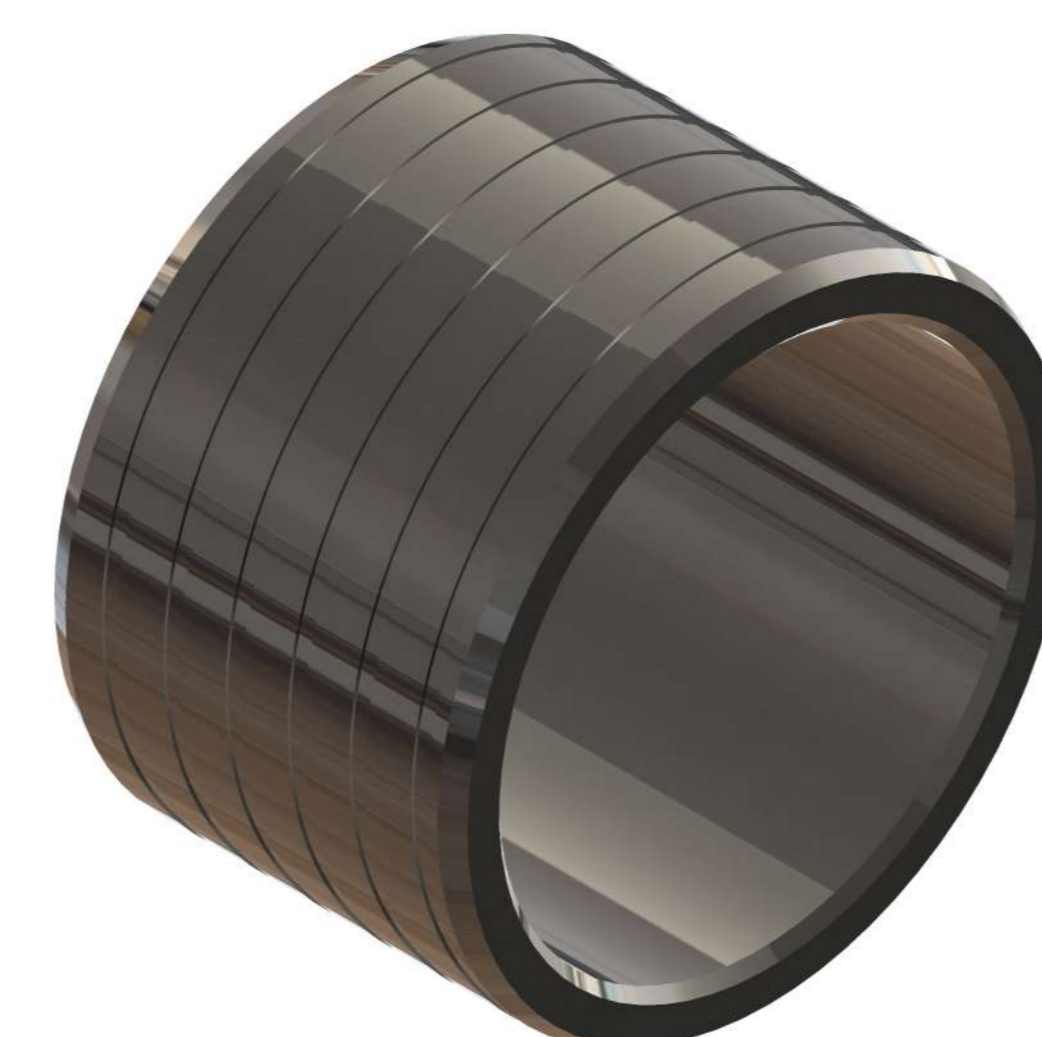

Bearing ring 25x30x20
UMS-01071554202



Compensation stud-bolt
UMS-01073432604

UNIVERSAL STATION

Standard components



Spring
UMS-01073332701



Axe
UMS-01126805203



Rear shim
UMS-01069215501



Compression spring
UMS-01073335101



Shaft
UMS-01131943401



Front shim
UMS-01069215602



Compensation cup
UMS-01074593801



Locking pin
UMS-01131943501

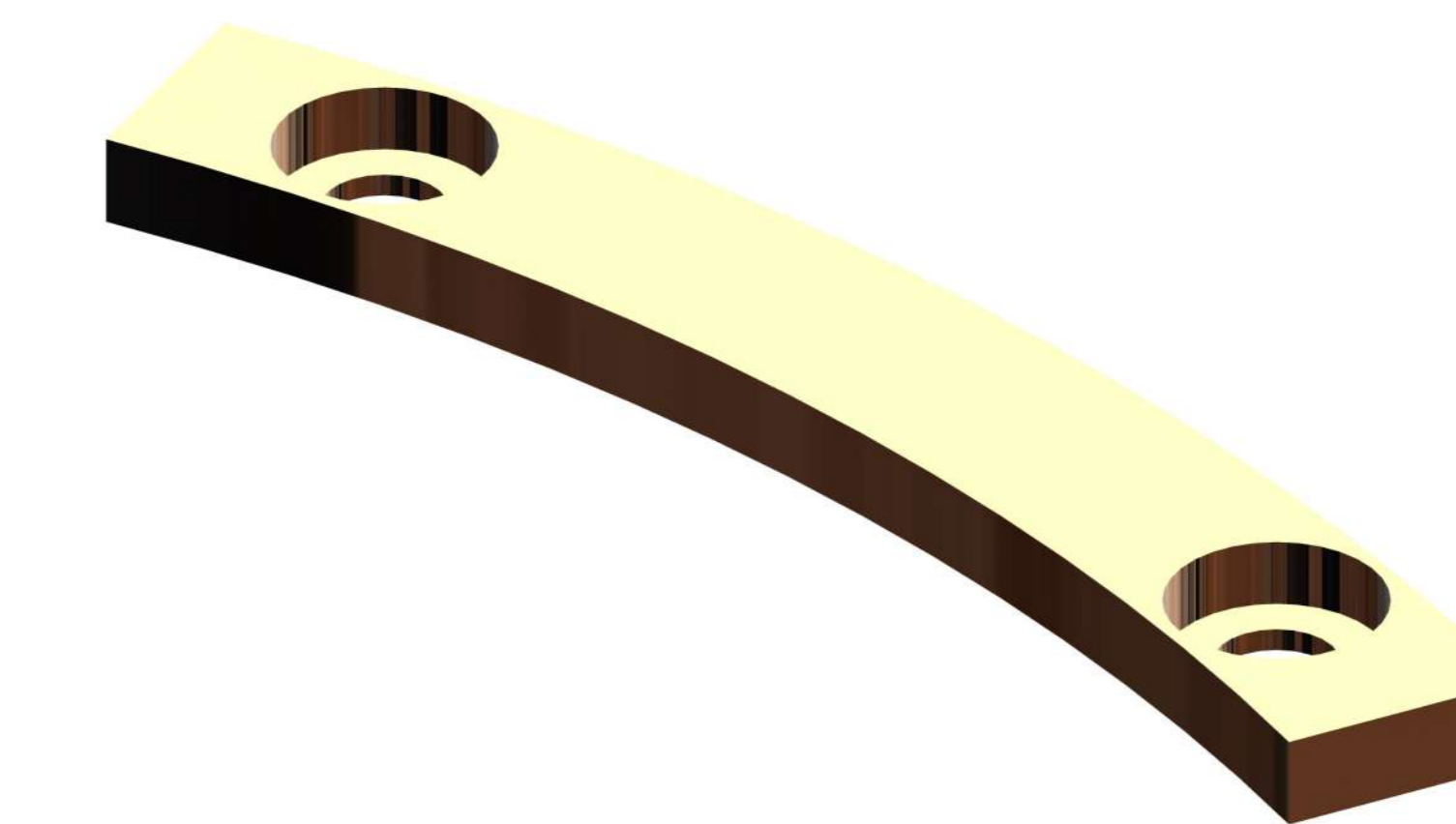

Rear slide
UMS-01069215402

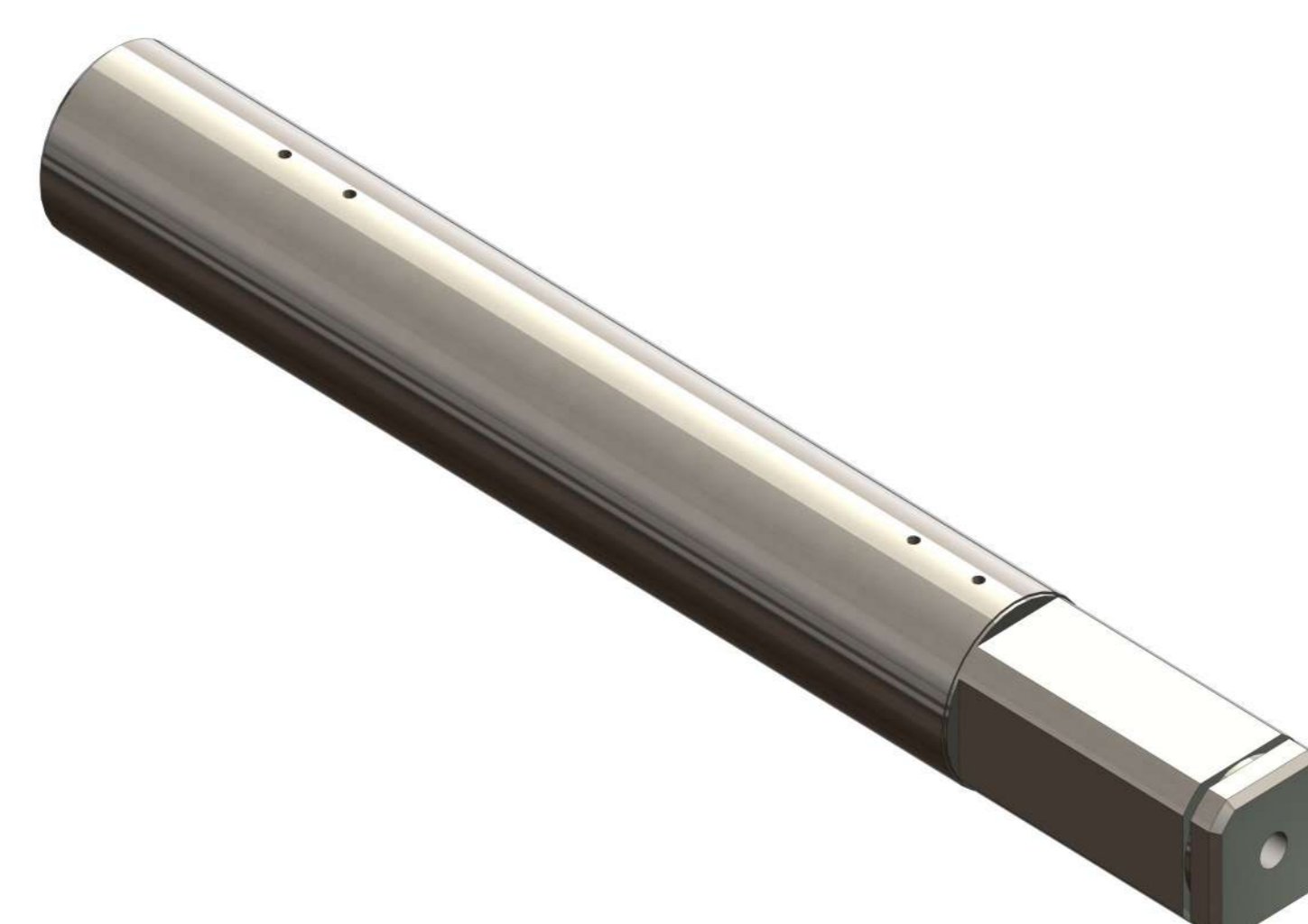

Shaft
UMS-01124310503

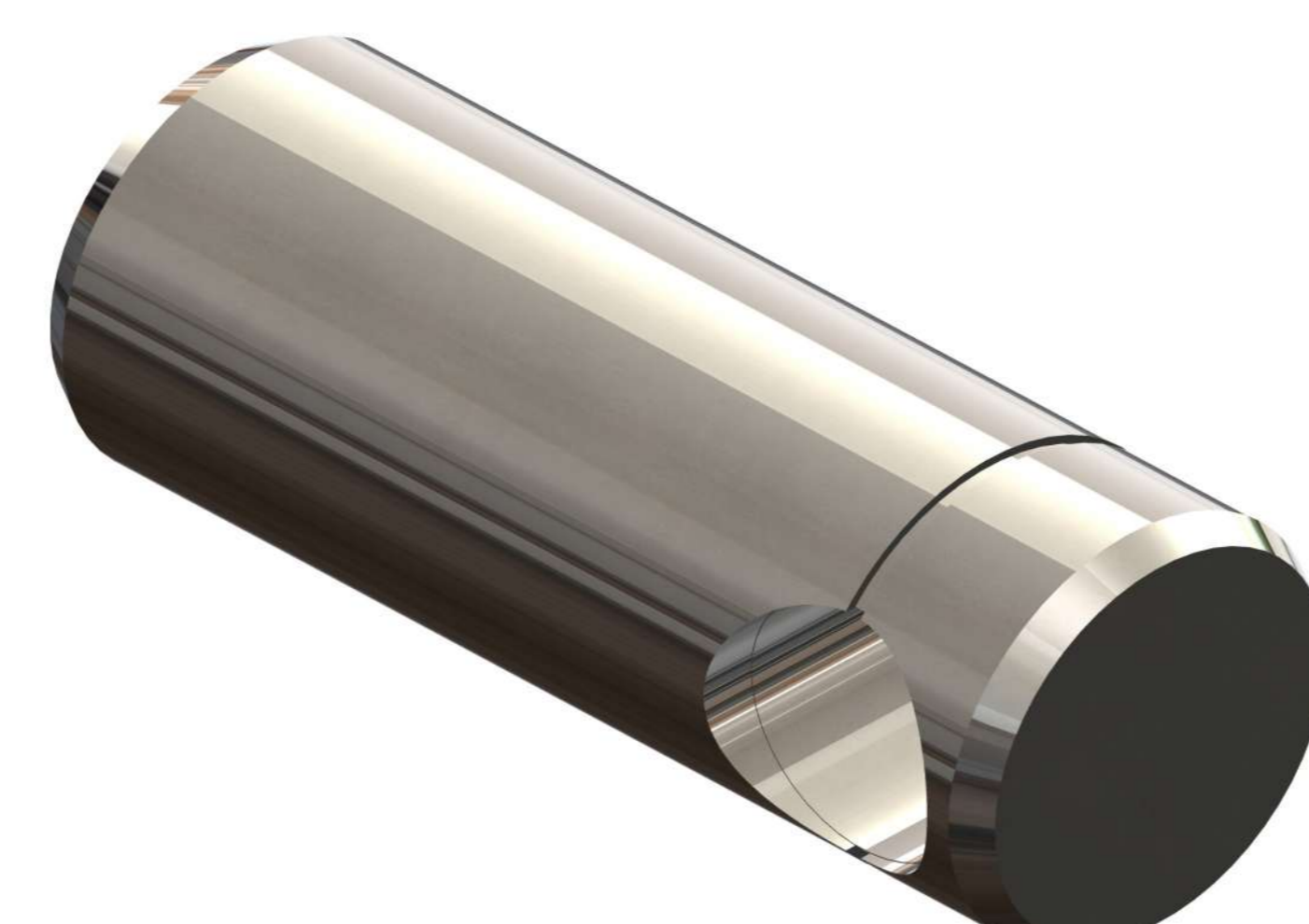

Locking pin

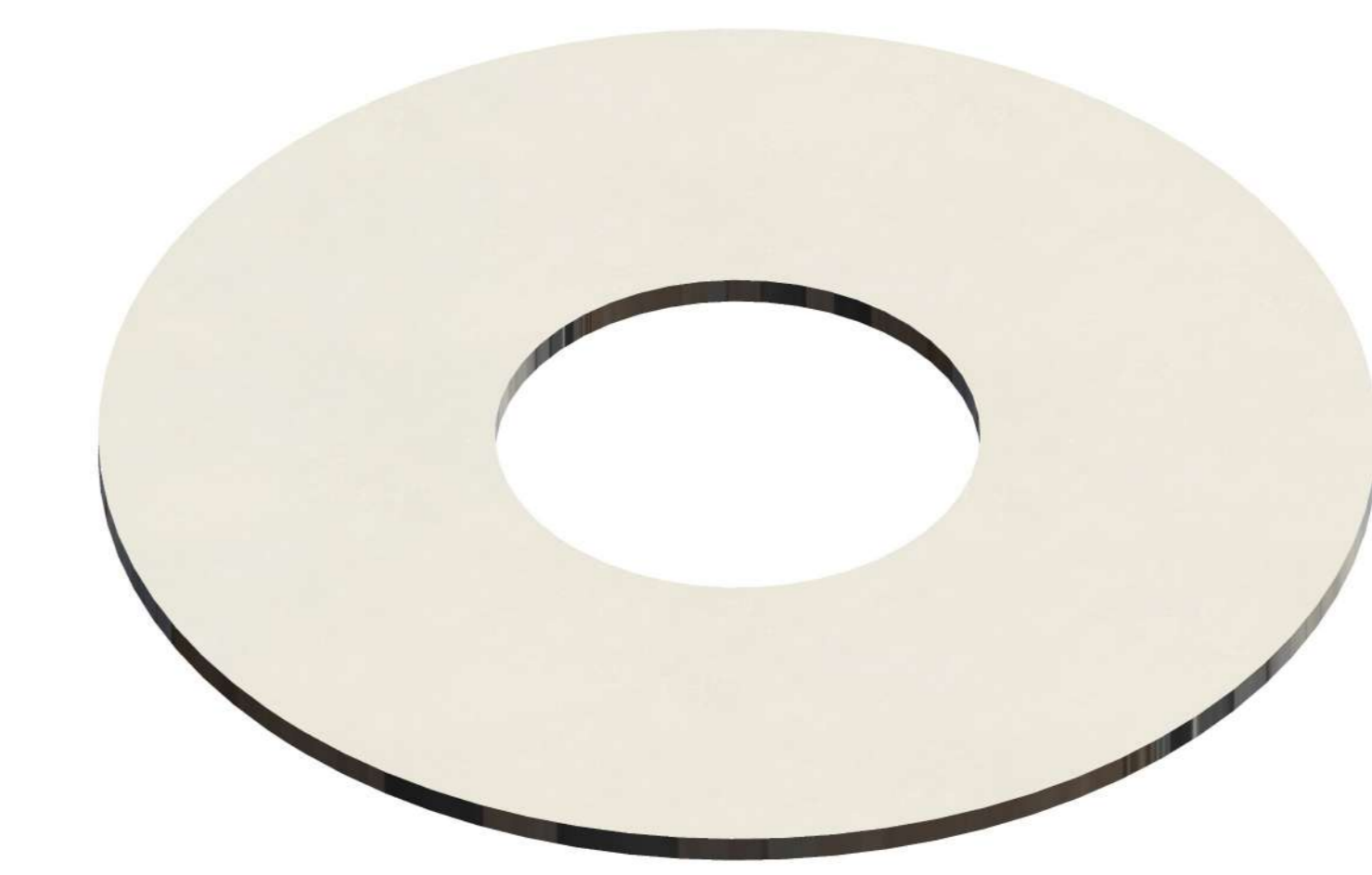

Washer
UMS-01060256900

VALVE S2

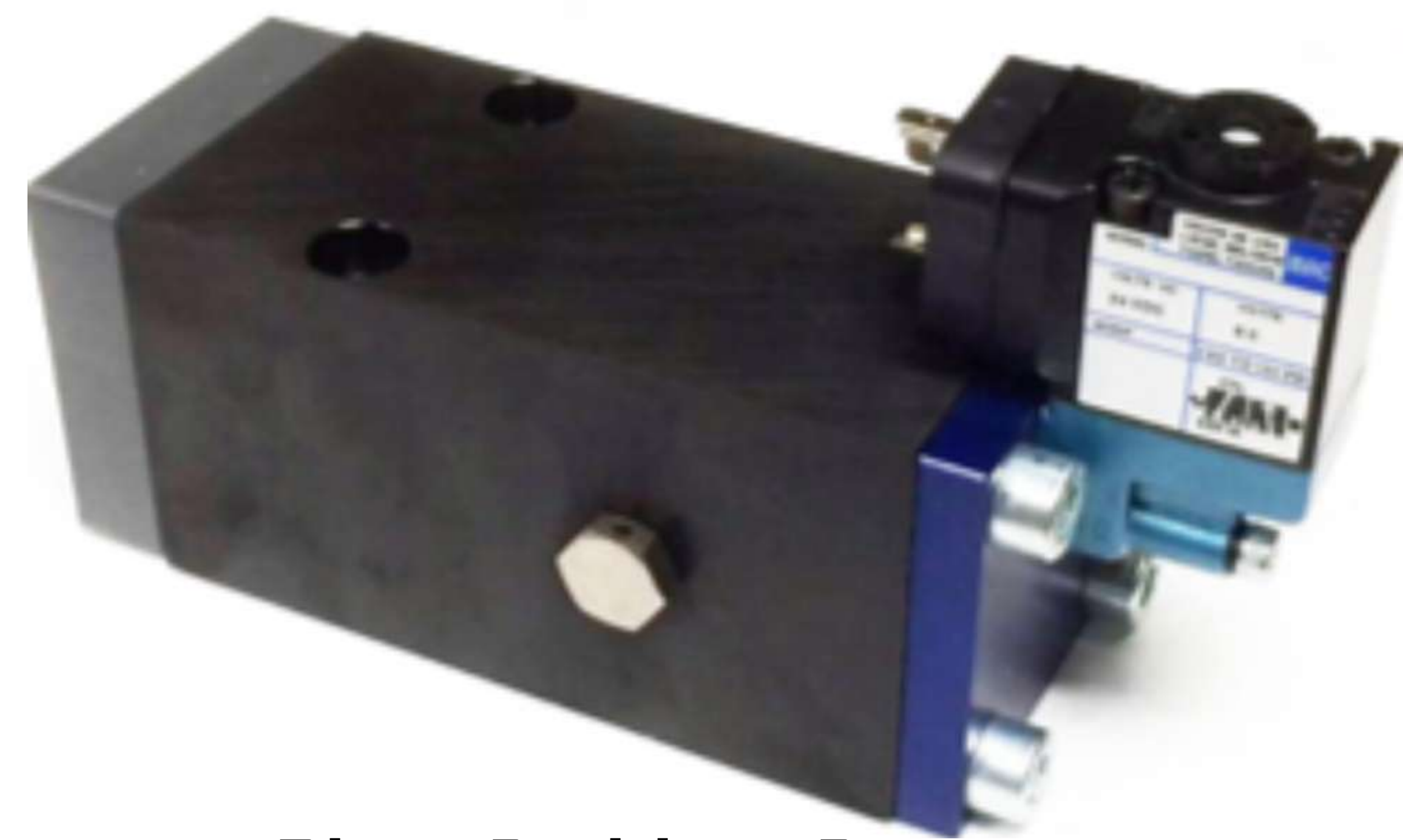

Blow, Preblow, Recovery

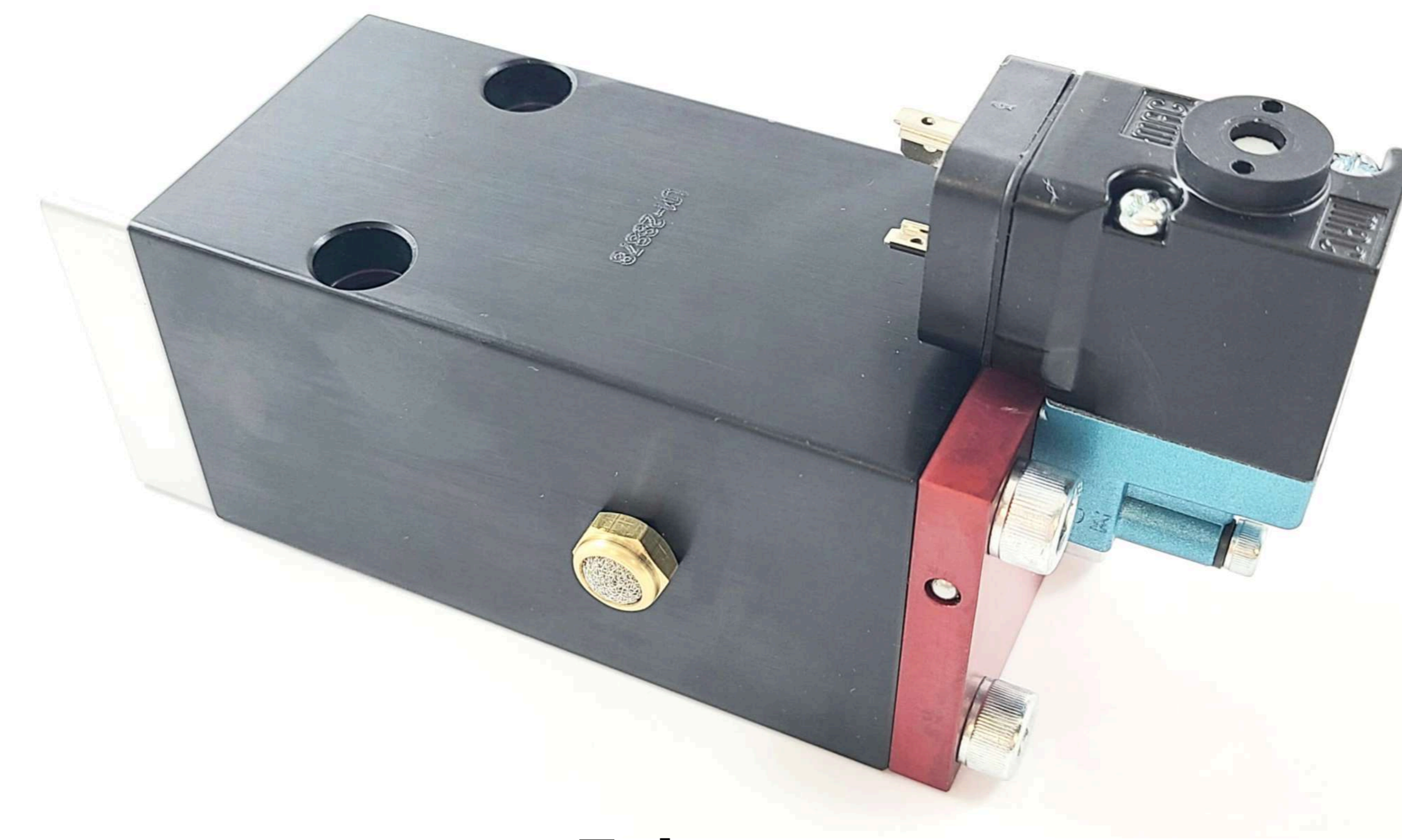

Exhaust



Rebuilt kit
UMS-114583NM02-KR



Plastic piston assy +
transport block
0002-001-05-24

Rebuilt parts



Blow/P-blow P.V. and Adapter
0002-001-01-47



Valve pilot universal
24V/DC/NO/NC
VPU24VDCNO/NCS2

Benefits

- Included all new components
- Improved plastic internal parts to reduce maintenance cost and time for rebuilding
- Ass'y composed of much less components
- Plug & play design
- No core return
- 1 year warranty
- Ideal for heat set machine or pressure over 35 bars

UM #	Description	Known OEM number
UMS-114583NM02	Improved S2 blow/preblow solenoid valve type (2628)	00000114583 00000086549 (Type 2628) 01169284101 01169284102 LH86549
UMS-114585NM02	Improved S2 exhaust solenoid valve type 2629 (86559)	00000114585 00000086559 (Type 2629) 01169284301 01169284302 LH86559

ECO VALVE S2



Blow, Preblow, Recovery



Exhaust

Benefits

Includes all new components

Improved internals to reduce maintenance cost and time for rebuild

Ass'y composed of much less components

Dead space volume reduced by 30% per station (compared to OEM valves)

Plug & play design

No core return

Ideal for water bottling company or pressure under 35 bars

Rebuilt parts

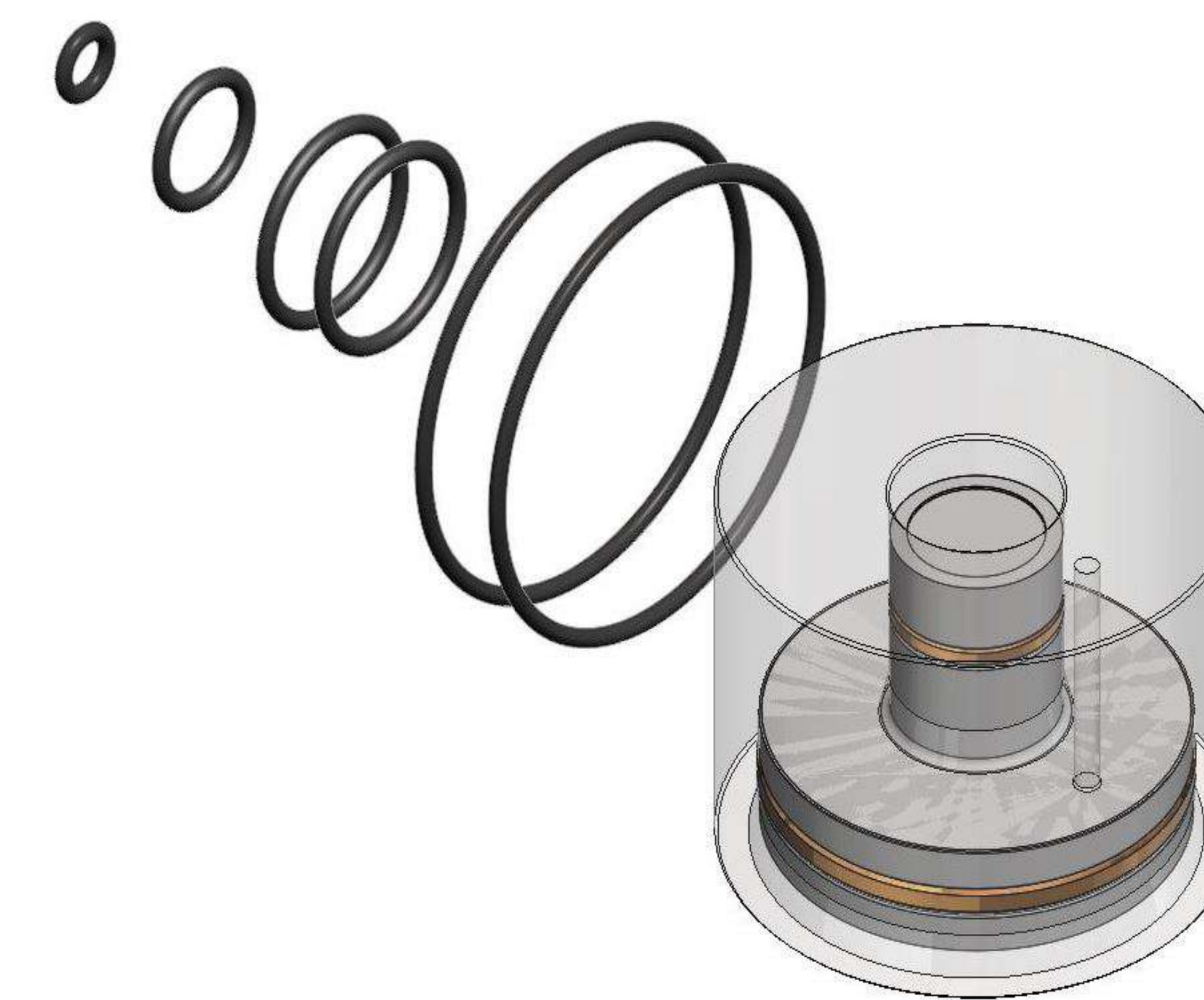

ECO valve maintenance parts
UMS-114583-ECO-KR

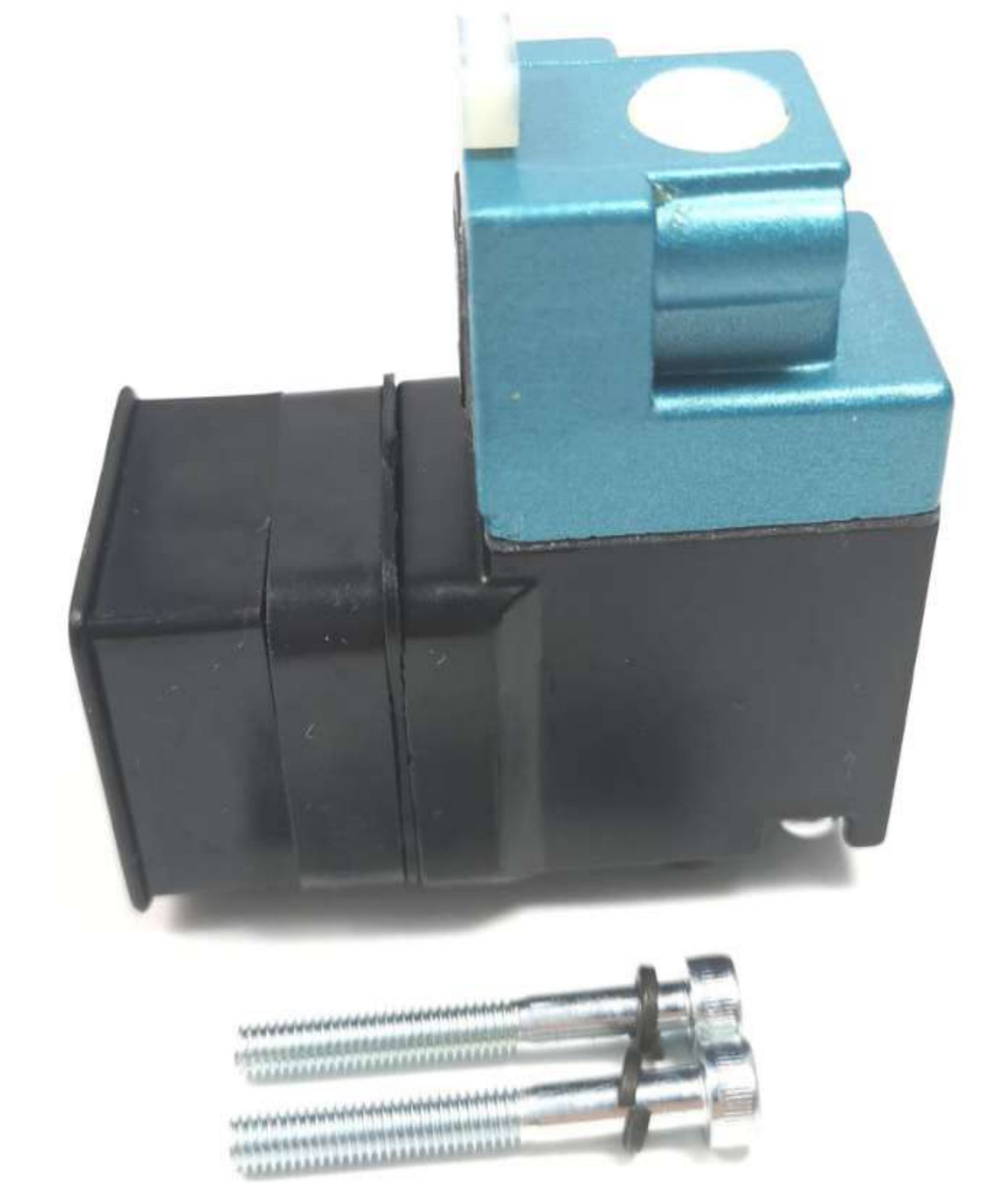

Valve pilot
VPU24VDCNO/NCS2

UM #	Description	Known OEM number
UMS-114583-ECO	S2 ECO valve preblow/blow/recovery	00000114583 00000086549 (Type 2628) 01169284101 01169284102 LH86549
UMS-114585-ECO	S2 ECO valve exhaust	00000114585 00000086559 (Type 2629) 01169284301 01169284301 01169284302 LH86559

VALVE S2 +

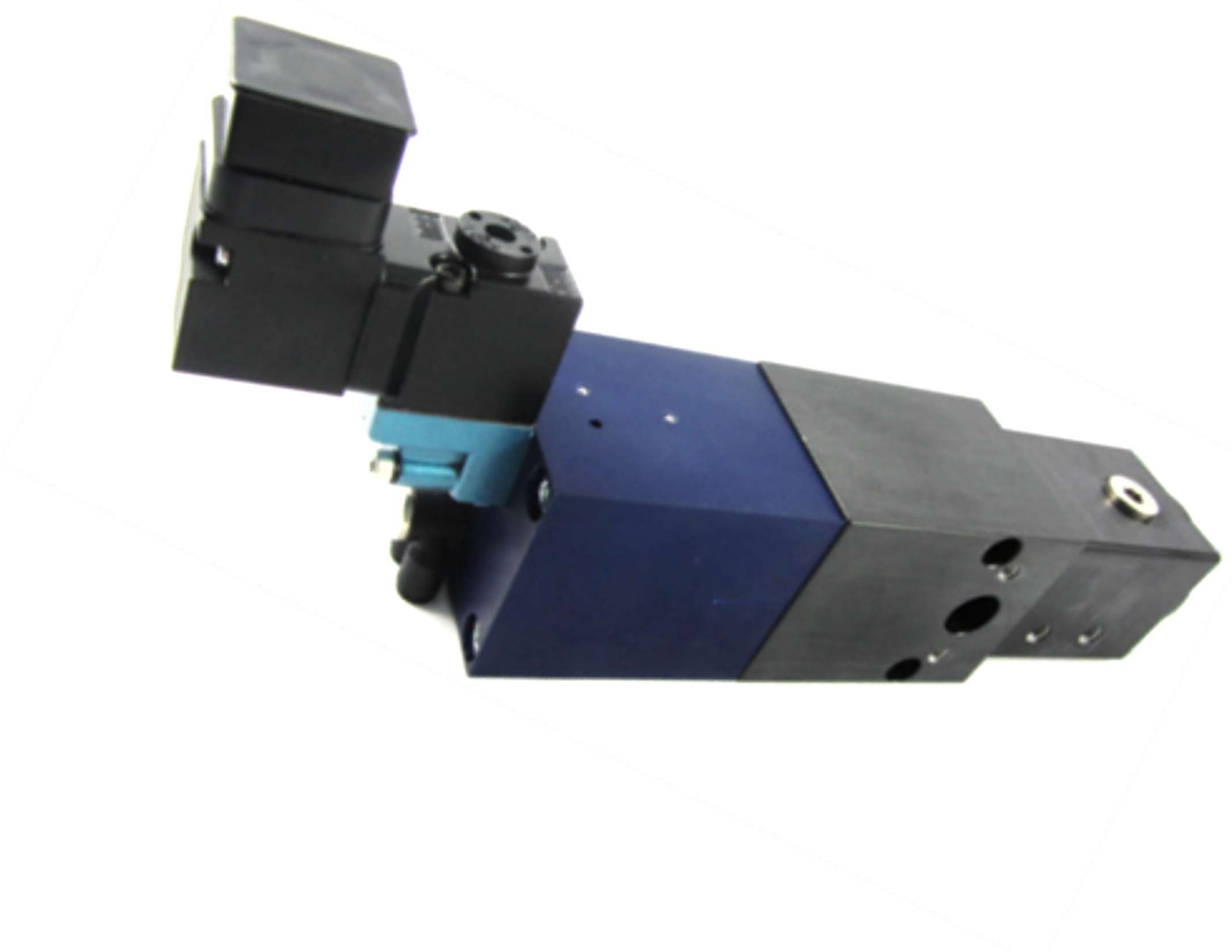

Rebuilt parts



Blow valve as assy rebuilt parts
UMS-224646NM-KR



Preblow & exhaust valve rebuilt parts
UMS-224647NM-KR
UMS-224648NM-KR

Improved recovery valve rebuilt parts
UMS-226565NM-KR

Standard components

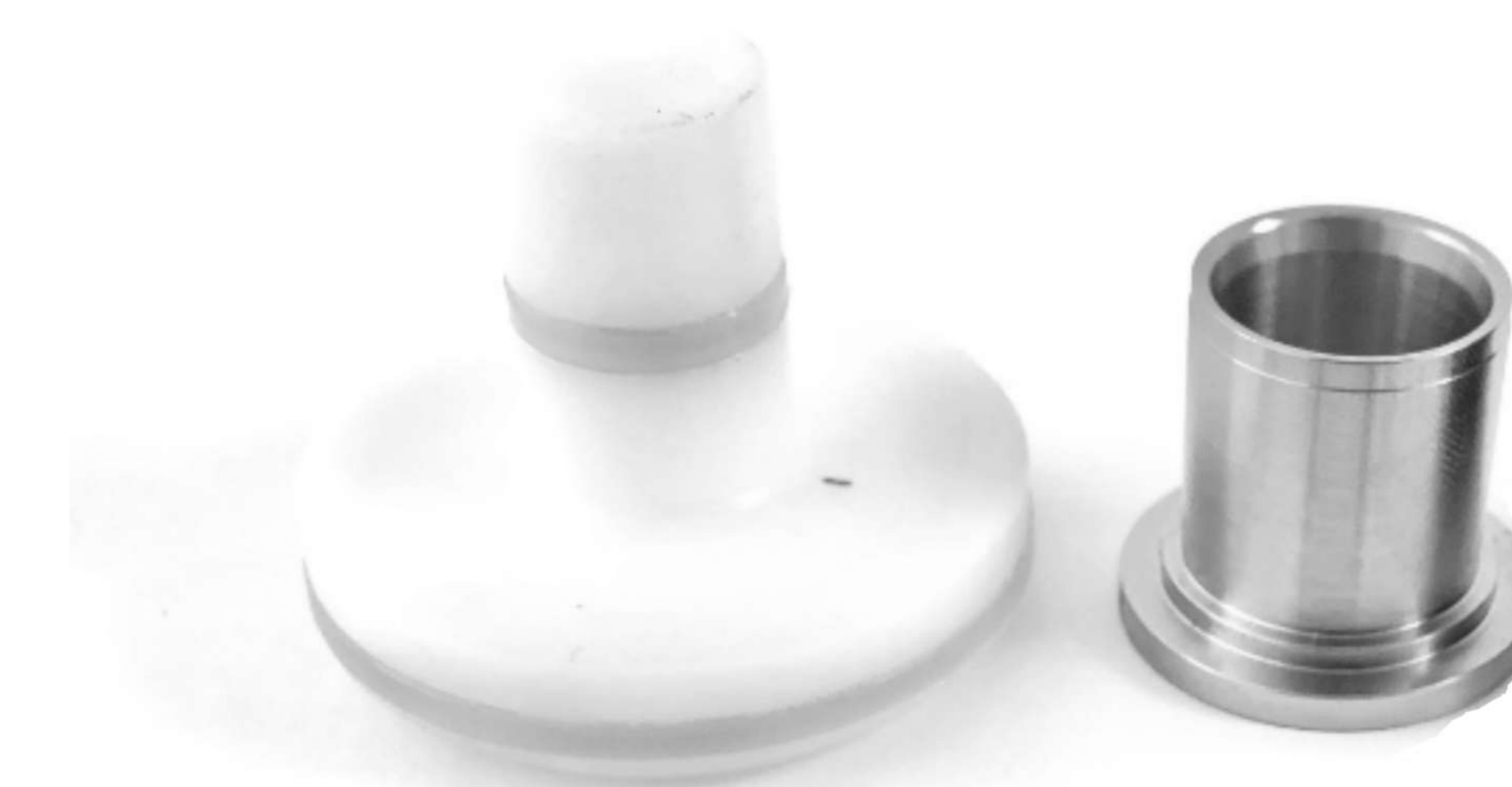

Universal piston kit with bushing
UMS-00000134975

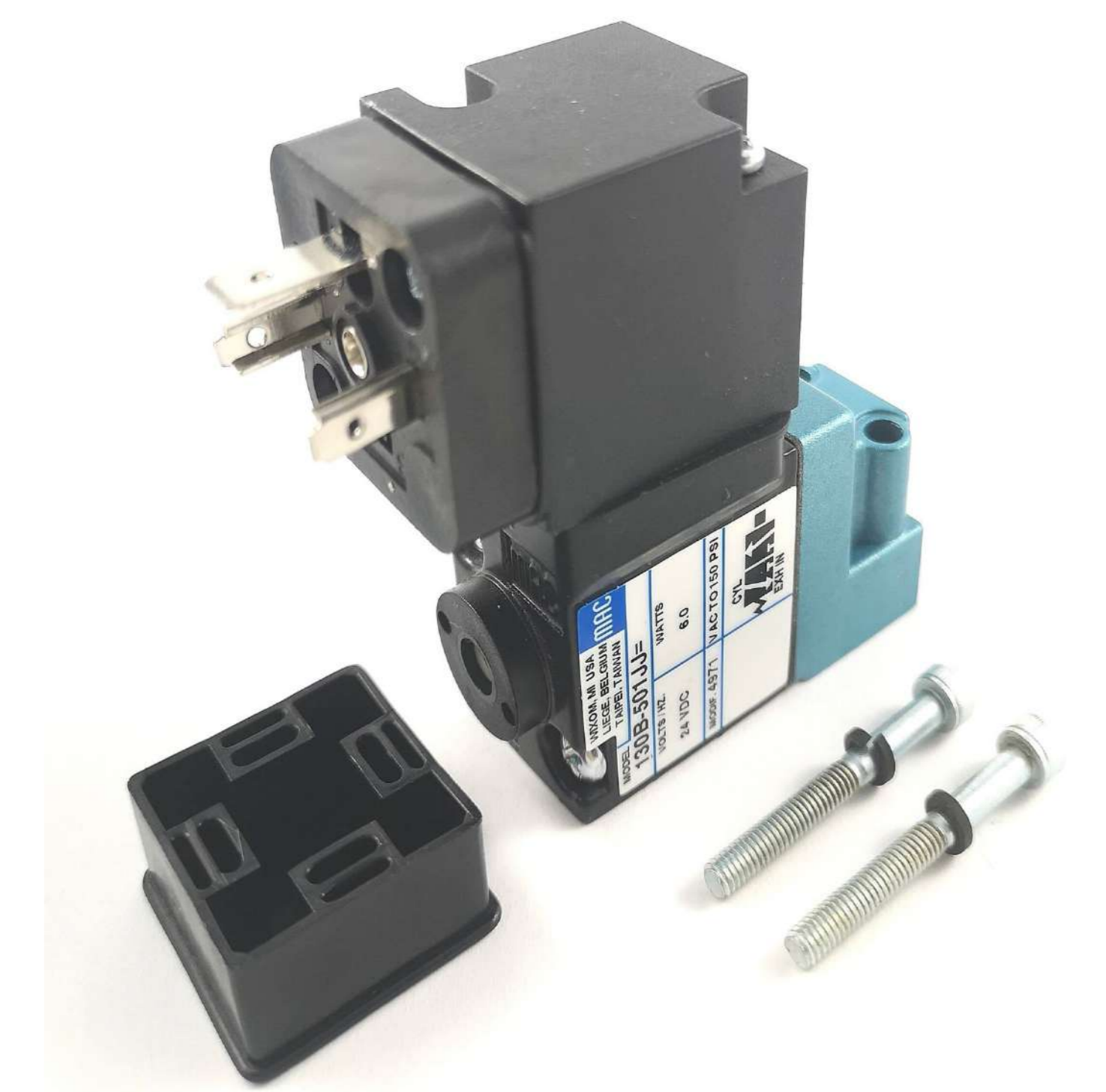

Universal pilot vane
24V/DC/NO/NC
VPU24VDCNO/NCS2PLUS

Benefits

- Included all new components
- Improved plastic internal parts to reduce maintenance cost and time for rebuilding
- Ass'y composed of much less components
- Plug & play design
- No core return
- 1 year warranty

UM #	Description	Known OEM number
UMS-224647NM	Preblow valve	01122464701 to 02 (Type 2792A)
UMS-224646NM	Blow valve	01122464601 to 02 (Type 2791A)
UMS-224648NM	Exhaust valve	01122464801 to 02 (Type 2793A)
UMS-226565NM	Recovery valve	01122447501 to 02 (Type 2795A)
UMS-224647NM + UMS-224646NM + UMS-224648NM	Blowing block (3 valves blow/preblow /exhaust)	01122447001 to 02 (Type 2794A)

ECO-MANIFOLD S2/S2 +



Benefits

- Compact unit that facilitate the maintenance process
- Dead space volume reduction within unit
- Interchangeable valves and components with universal blowmolders
- Fits in actual frame without modification
- Significant air consumption reduction
- Machines branded Sidel* S2 : 12 in 3
- Machines branded Sidel* S2+ : 1 in 3
- 1 year warranty

Rebuilt parts



Universal compact valve rebuilt parts
UMS-131938-COMPACTKR



Cover plate blow/preblow/recovery
UMS-CPB-COMPACT

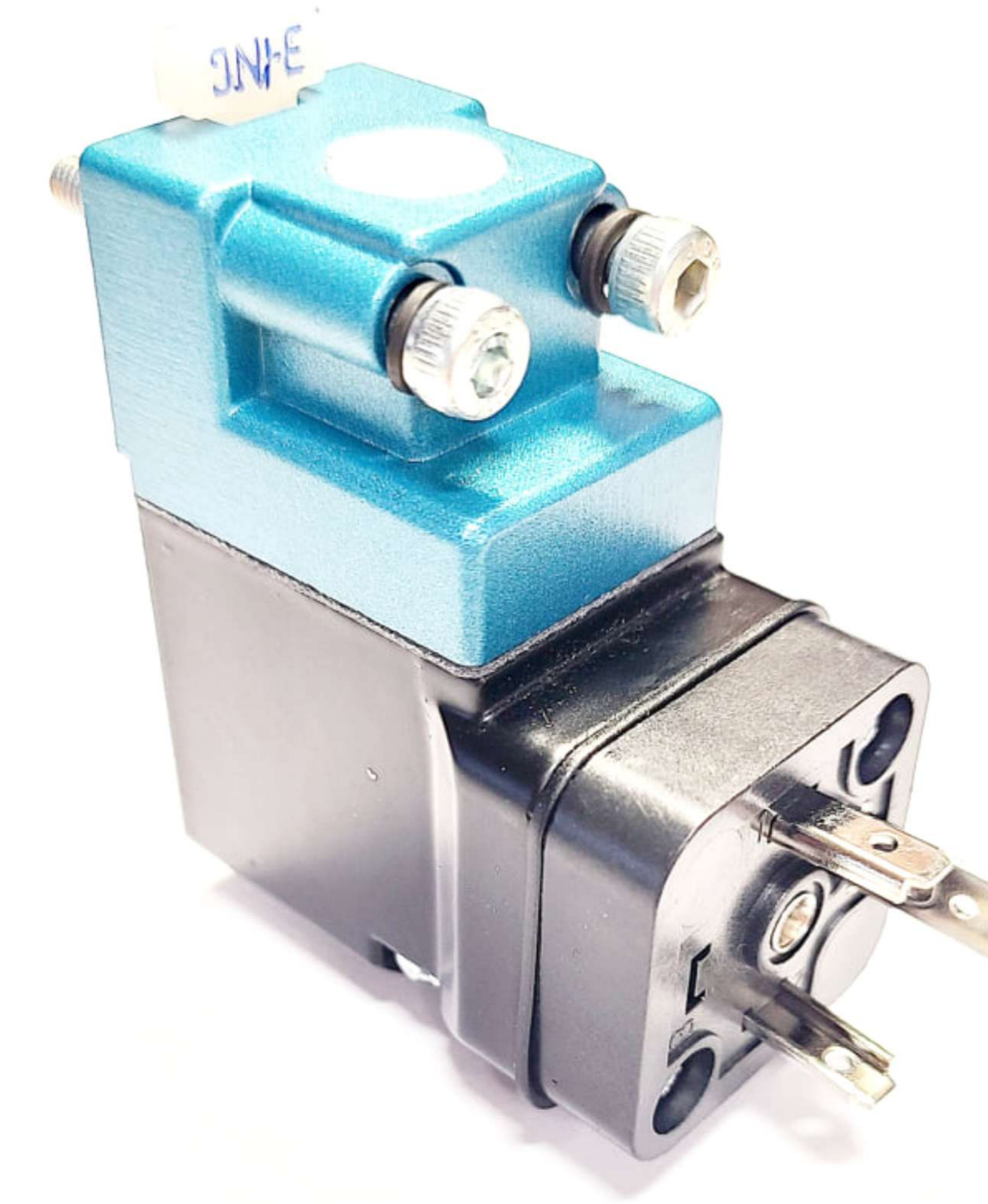

Pilot valve
VPU24VDCNO/NC:8590

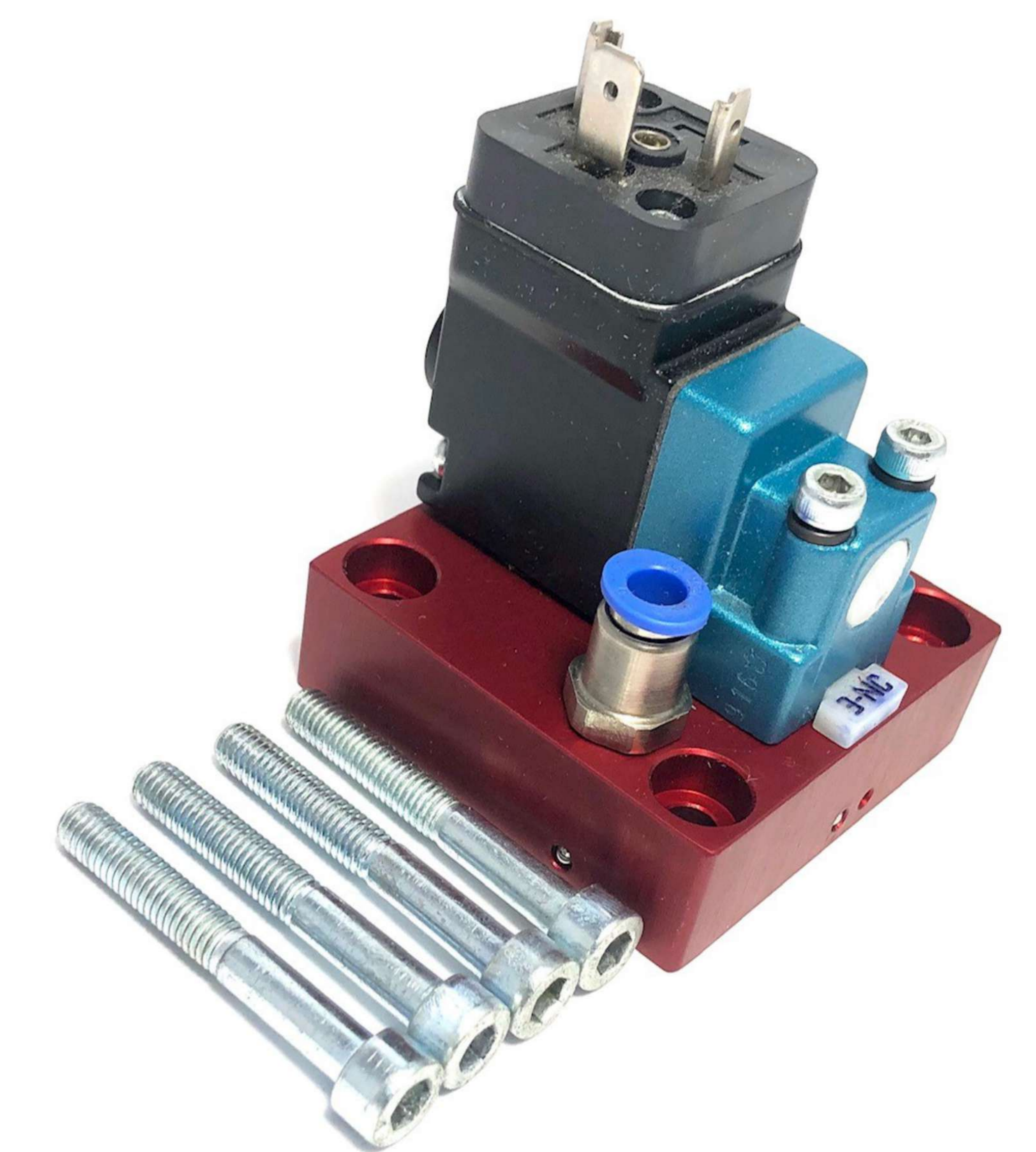

Cover plate exhaust
UMS-CPE-COMPACT

UM #	Description	Known OEM number
UMS-MANI-UNI-S2-3V-2S-PHD	Manifold PHD blow nozzle, 3 valves	
UMS-MANI-UNI-S2-4V-3S-PHD	Manifold PHD blow nozzle, 4 valves	
UMS-MANI-UNI-S2-3V-2S	Manifold conversion S2 with 3 valves	
UMS-MANI-UNI-S2-4V-3S	Manifold conversion S2 with 4 valves	
UMS-MANI-UNI-S2+-3V-2S	Manifold conversion S2+ with 3 valves	
UMS-MANI-UNI-S2+-4V-3S	Manifold conversion S2+ with 4 valves	

VERTICAL STACK AND HYBRID S2 +

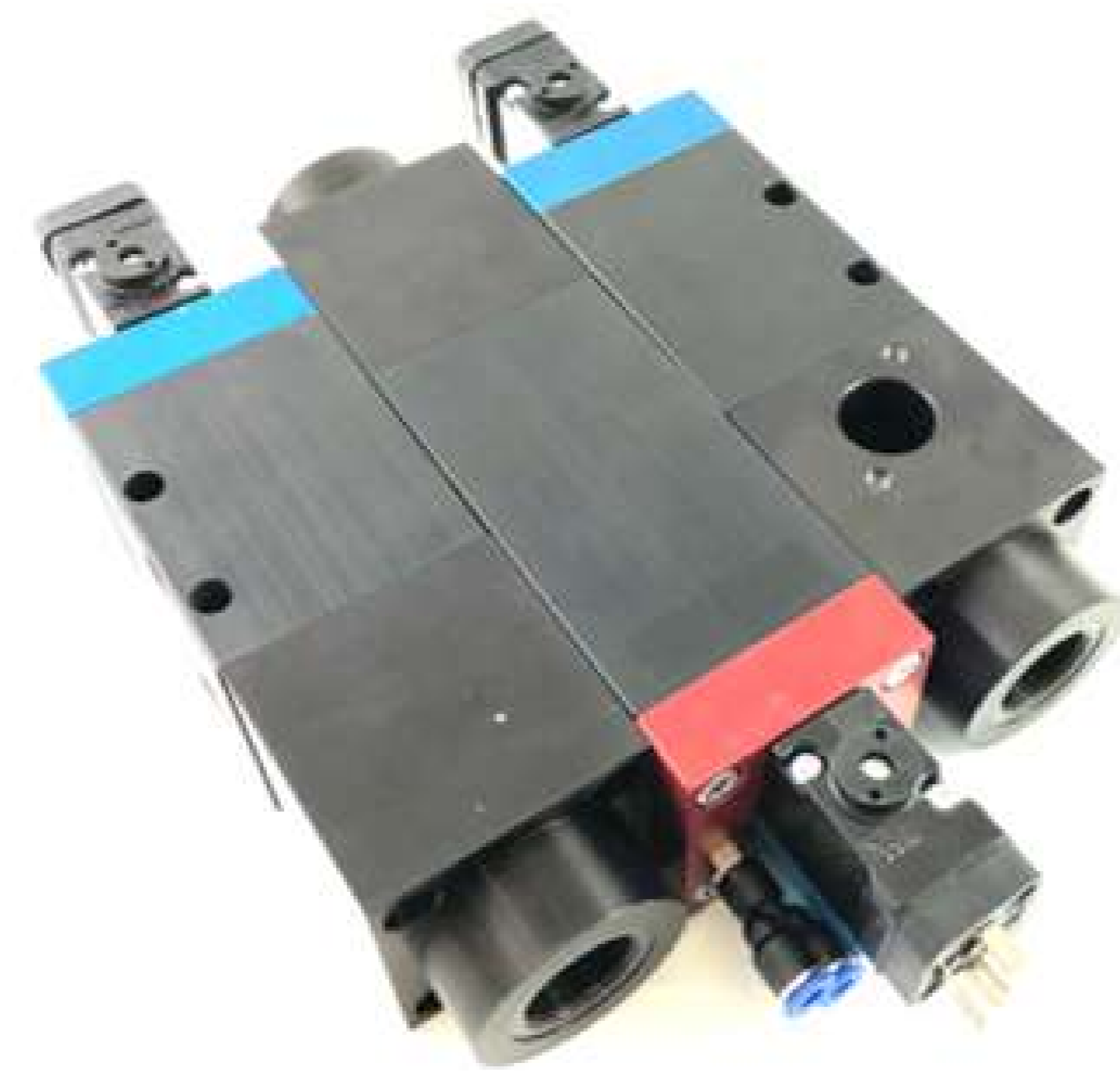

Benefits

- Included all new components
- Improved plastic internal parts to reduce maintenance cost and time for rebuild
- Ass'y composed of much less components
- Plug & play design
- No core return
- 1 year warranty

Standard components



Universal piston parts with bushing
UMS-00000134975

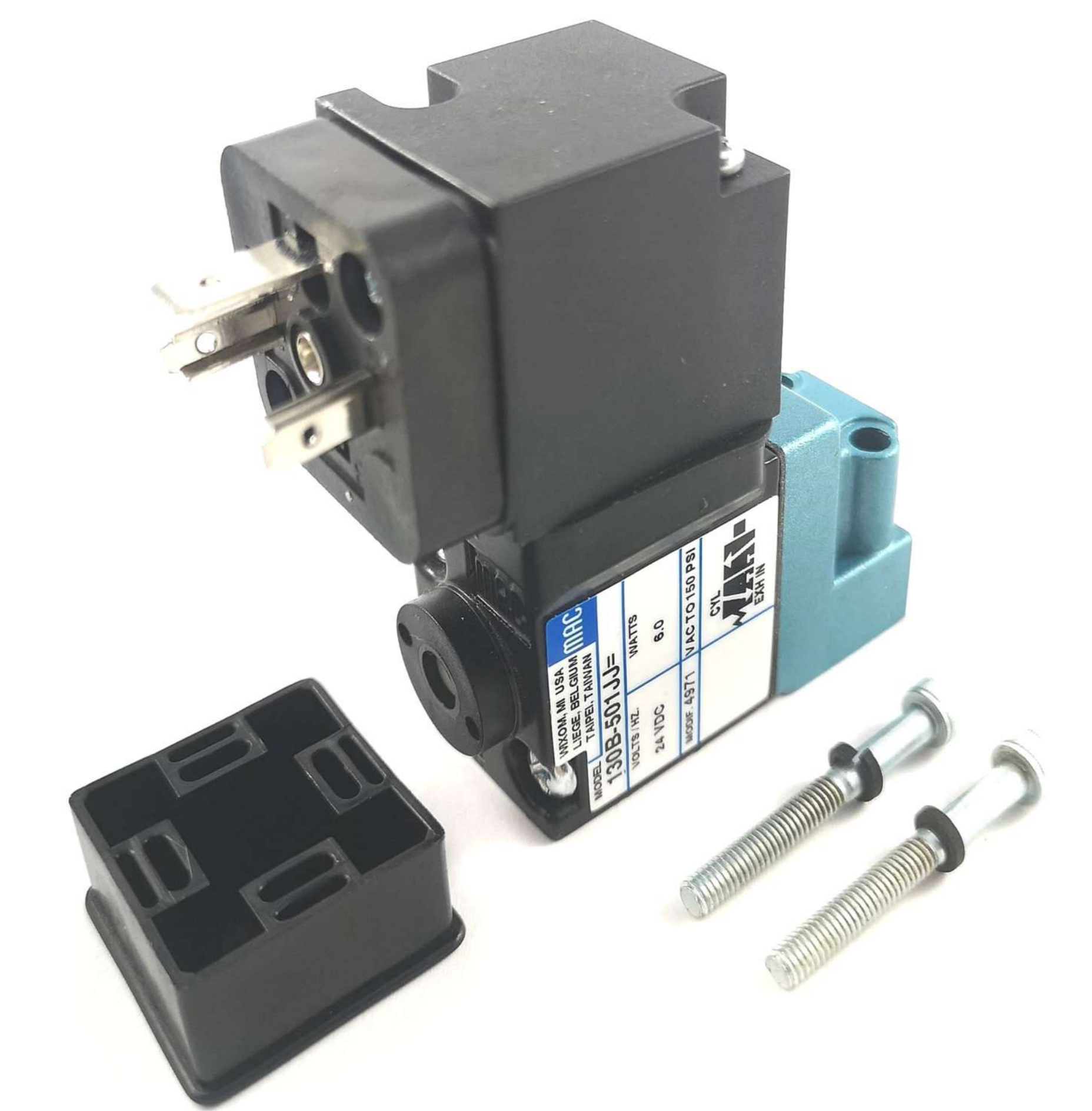

Universal pilot vane
24V/DC/NO/NC
VPU24VDCNO/NC S2PLUS

UM #	Description	Known OEM number
UMS-087693NM	S2 (H) preblow valve	00000087693
UMS-087692NM	S2 (H) blow valve	00000087692
UMS-087695NM	S2 (H) exhaust valve	00000087695
UMS-106339M	S2 (S) preblow valve as ass'y	00000106339
UMS-106340M	S2 (S) blow valve as ass'y	00000106340
UMS-106338M	S2 (S) exhaust valve as ass'y	00000106338

UNIVERSAL VALVE



Universal blow valve rebuilt parts
UMS-00000141762M



Piston
UMS-00000138235M

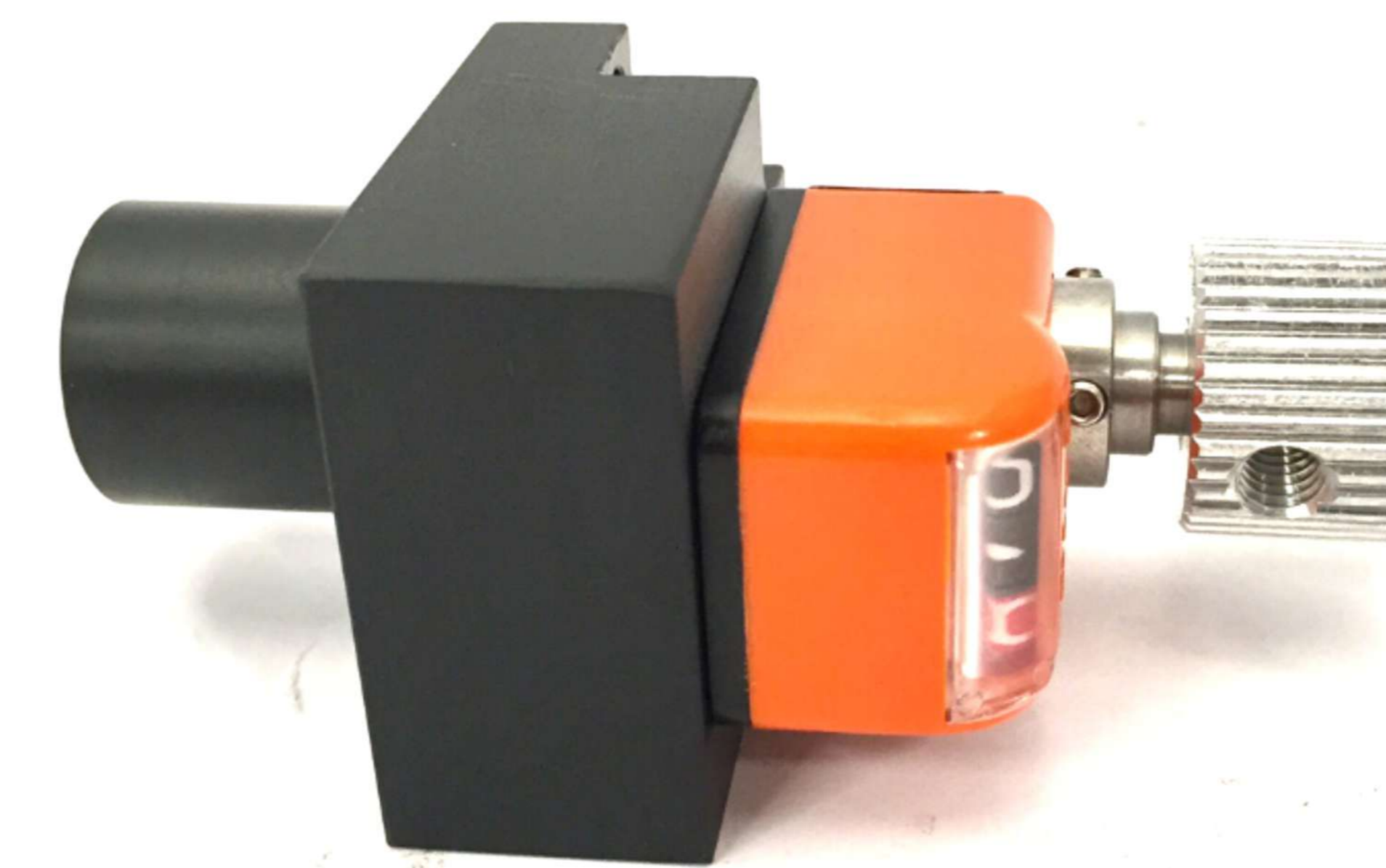

Pressure limiter
UMS-00000137198M

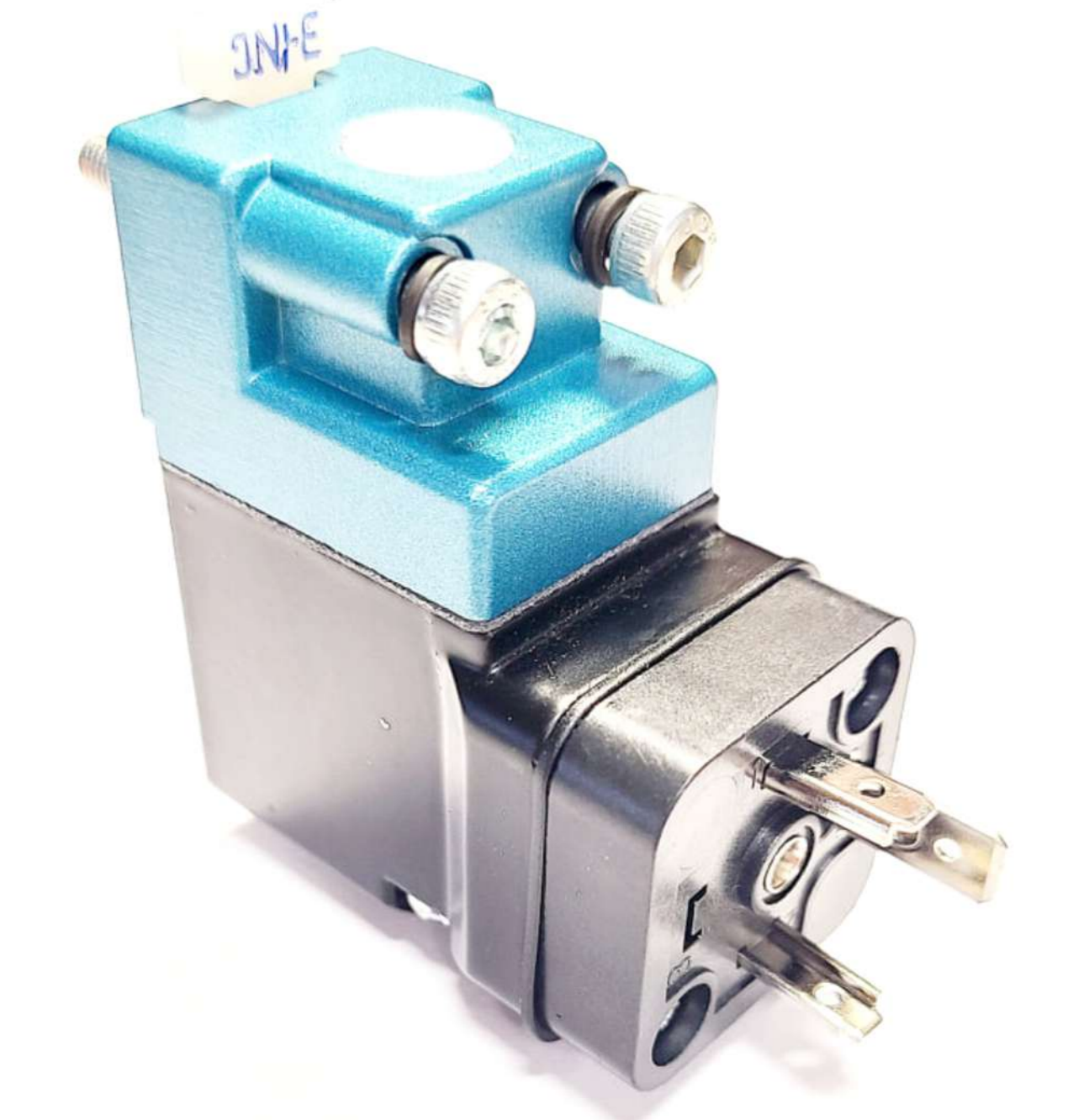

Pilot valve
VPU24VDCNO/NC:8590

Rebuilt parts



Cover plate blow/
preblow/recovery
UMS-CPB-UNIVERSAL

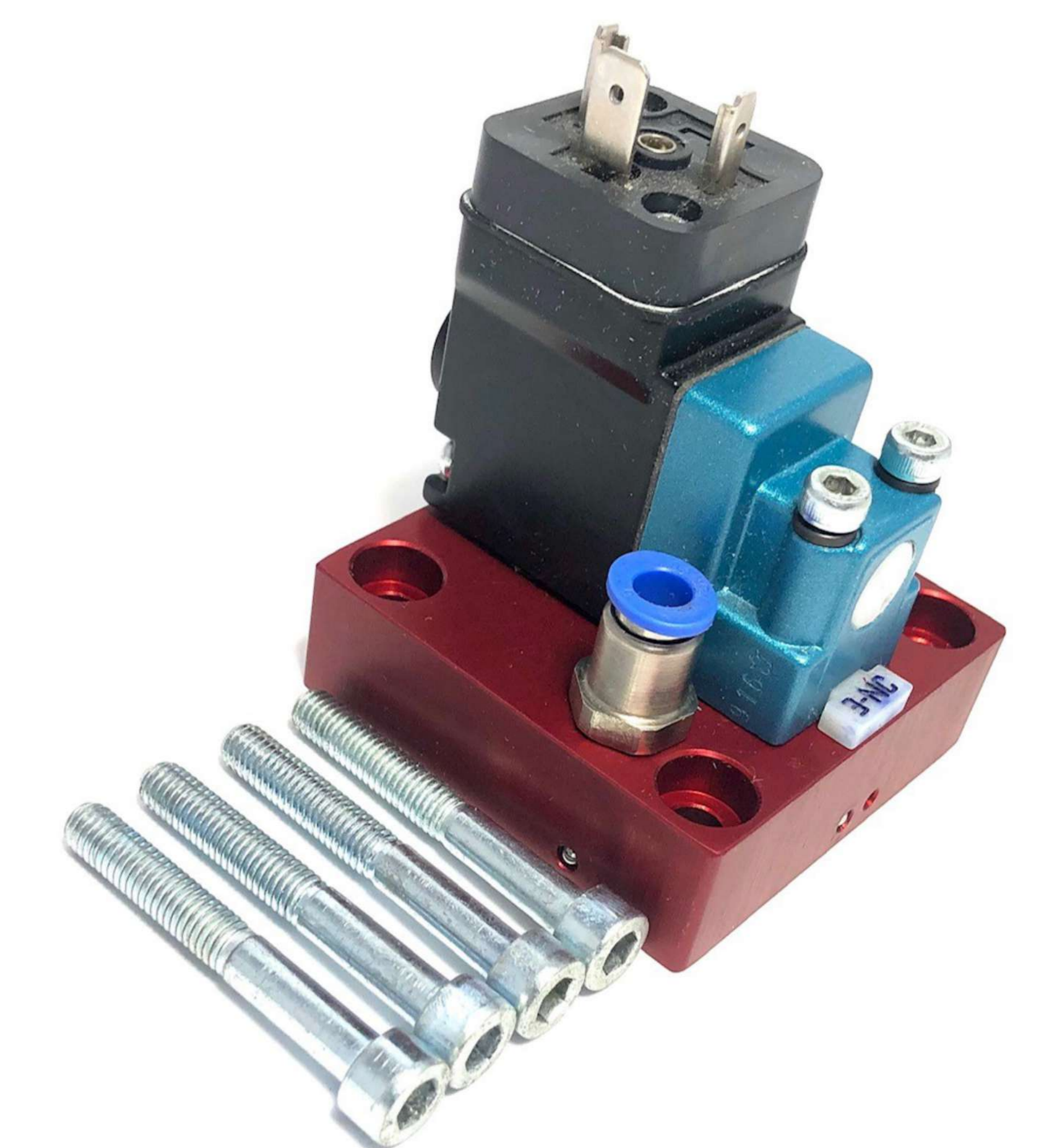

Cover plate exhaust
UMS-CPE-UNIVERSAL

Benefits

Maintenance cost reduction

Plug-and-play valve in current configuration on universal blowmolder

Ideal for heat set machine or pressure over 35 bars

UM #	Description	Known OEM number
UMS-00000131938M	Universal blow/preblow/ recovery valve	<p>OEM internal parts are in metal 00000115982 (Type 2828)</p> <p>OEM internal parts are in plastic 00000131938 (Type 2828 LC)</p> <p>OEM Design changed inside + mac pilot valve 01177388601 (Type 2828 LC2)</p> <p>OEM Design changed inside + black pilot valve 01177331201 (Type 2828 LC2)</p>
UMS-00000131939M	Universal exhaust valve	<p>OEM internal parts are in metal 00000115983 (Type 2829)</p> <p>OEM internal parts are in plastic 00000131938 (Type 2829 LC)</p> <p>OEM Design changed inside + mac pilot valve 01177388701 (Type 2829 LC2)</p> <p>OEM Design changed inside + black pilot valve 01173131601 (Type 2829 LC2)</p>

UNIVERSAL COMPACT VALVE



Blow, Preblow, Recovery



Exhaust



Rebuilt kit
UMS-131938-COMPACTKR

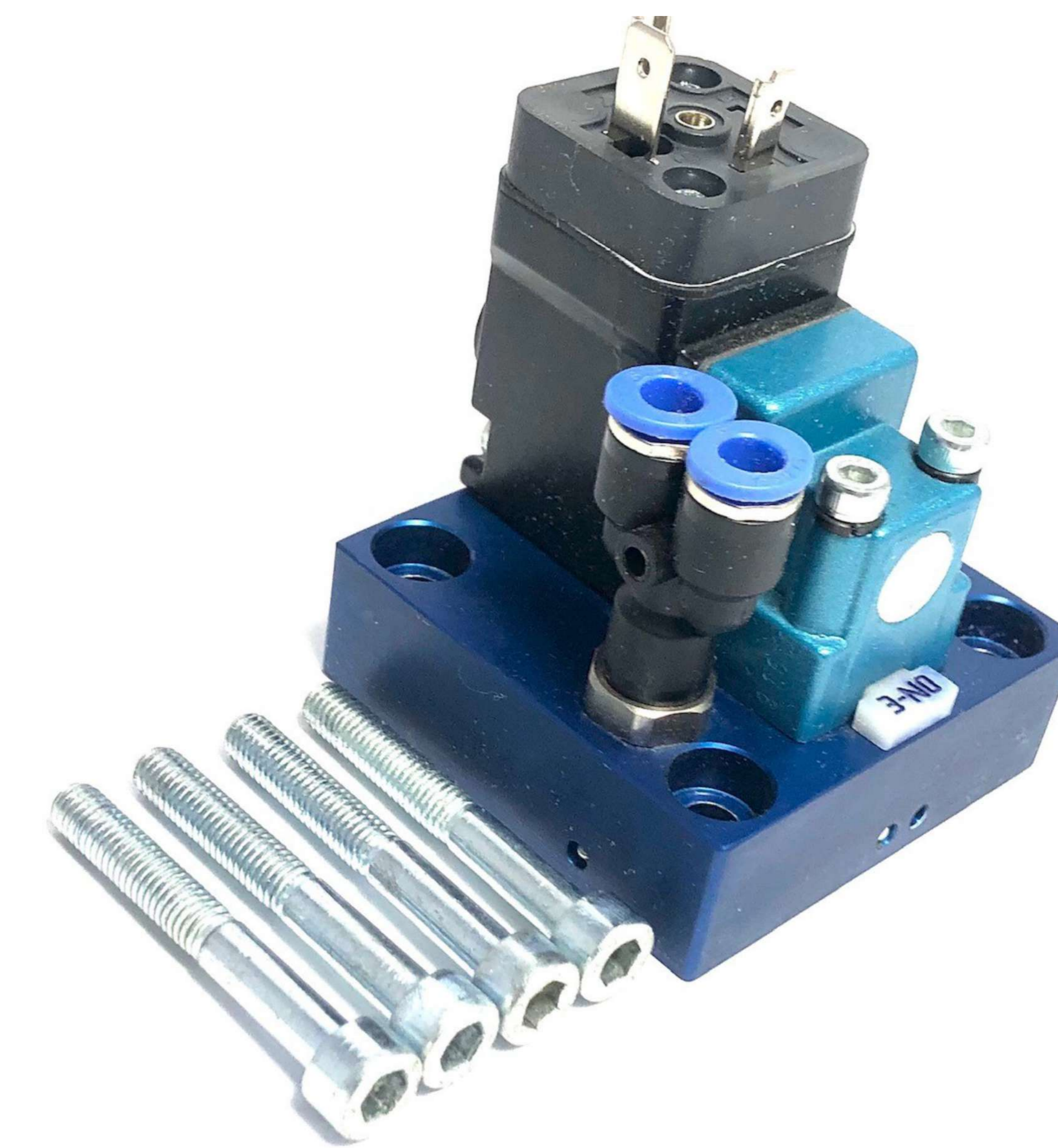

Cover plate blow/
preblow/recovery
UMS-CPB-COMPACT

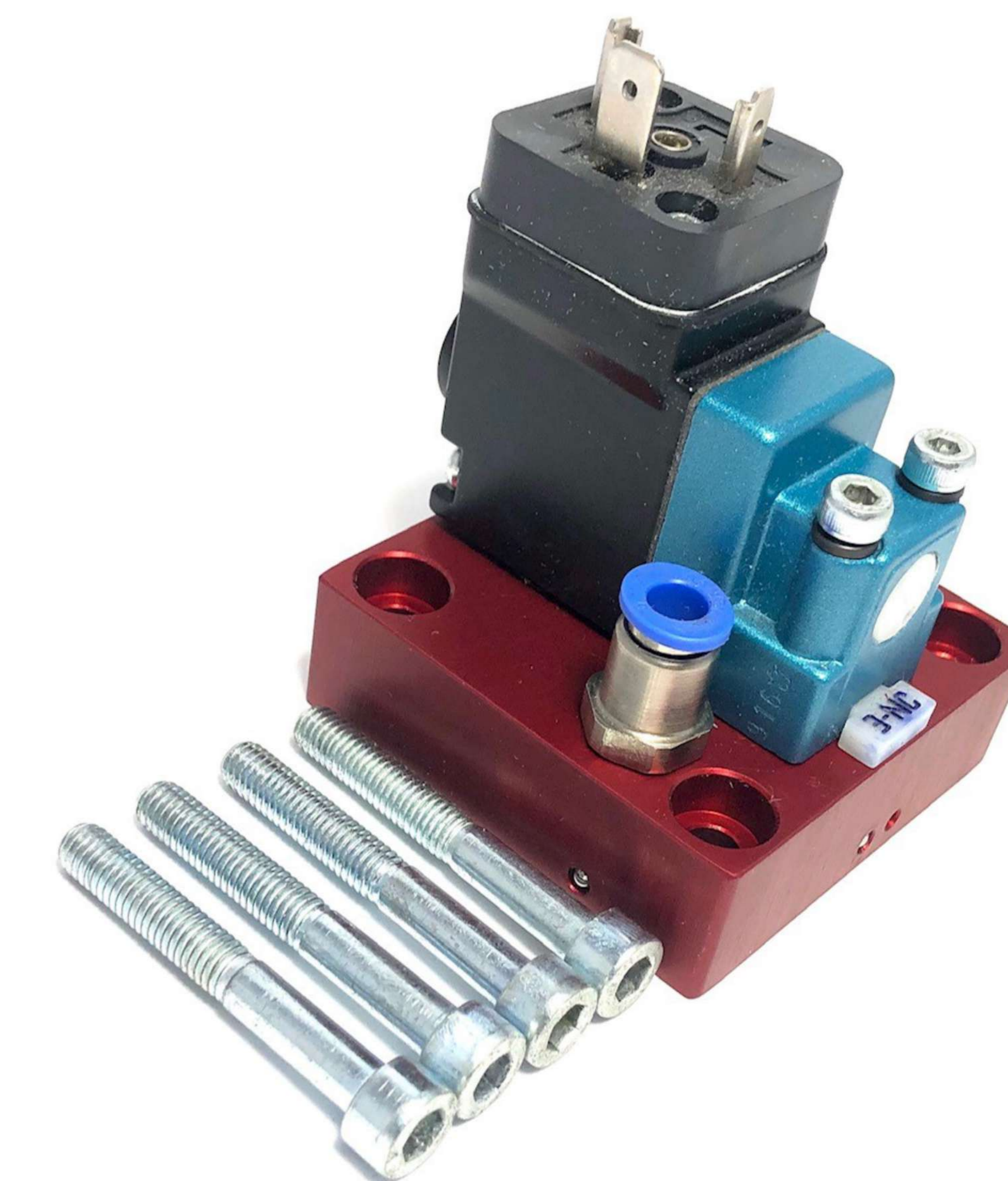

Cover plate exhaust
UMS-CPE-COMPACT

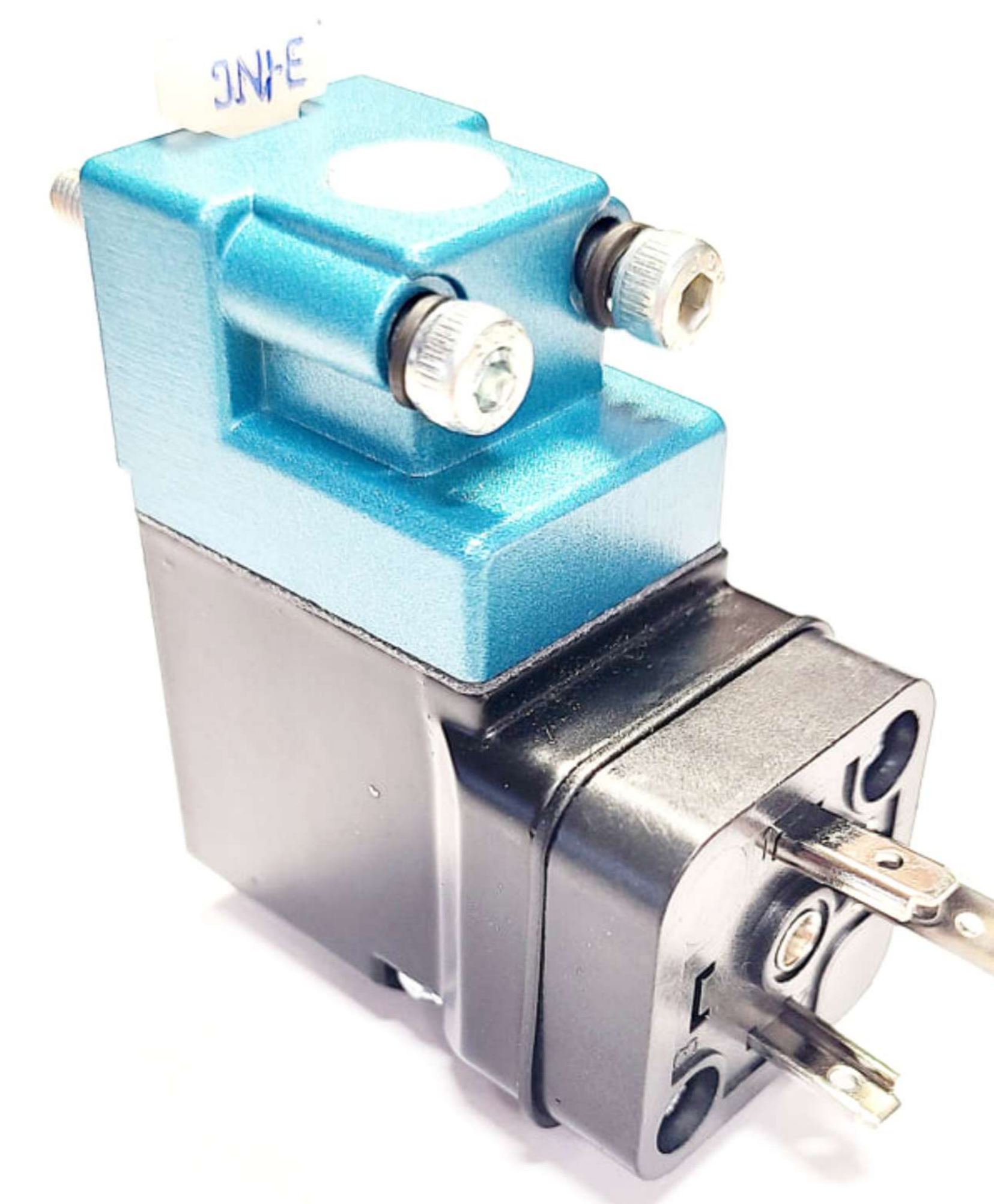

Pilot valve
VPU24VDCNO/NC:8590

Rebuilt parts

Benefits

- Compact unit that eliminates the valve float
- Maintenance cost reduction
- Plug-and-play valve in current configuration on universal blowmolder
- Ideal for water bottling company or pressure under 35 bars

UM #	Description	Known OEM number
UMS-131938-COMPACT	Universal blow/preblow/ recovery compact valve	OEM internal parts are in metal 00000115982 (Type 2828)
		OEM internal parts are in plastic 00000131938 (Type 2828 LC)
		OEM Design changed inside + mac pilot valve 01177388601 (Type 2828 LC2)
		OEM Design changed inside + black pilot valve 01177331201 (Type 2828 LC2)
UMS-131939-COMPACT	Universal exhaust compact valve	OEM internal parts are in metal 00000115983 (Type 2829)
		OEM internal parts are in plastic 00000131938 (Type 2829 LC)
		OEM Design changed inside + mac pilot valve 01177388701 (Type 2829 LC2)
		OEM Design changed inside + black pilot valve 01173131601 (Type 2829 LC2)

OTHER PARTS AVAILABLE

UM #	Description	Known OEM equivalent number	UMS-01065579600	Shaft	01065579600
			UMS-01065579700M	Sprocket	01065579700
			UMS-01065631600	Finger with thread	01065631600
UMS-0000000336M	Up/Down wheel	0000000336	UMS-01065905400	Dowel pin	01065905400
UMS-0000001758	Spring C 075.110.0320 I	0000001758	UMS-01066339202	Stop nut for S1 QC chain	01066339202
UMS-0000013323	Castle lock nut assy	0000013323	UMS-01066352803	Cylinder lower	01066352803
UMS-0000017317	Parallele key FC 4x4x6.5	0000017317	UMS-01066353700	Sheath for oven chain	01066353700
UMS-0000020111	Compensation seal GUPM	0000020111	UMS-01066471002	Spring fastening	01066471002
UMS-0000022777	Rod seal 14X20.2X3	0000022777	UMS-01067139801	Spring	01067139801
UMS-0000109521	Ball-Bearing Roller	0000109521	UMS-01067300302	Upper cylinder	01067300302
UMS-0000109780	Rod seal 159056HGK6	0000109780	UMS-01067535604	Support block for outer straight exit	01067535604
UMS-0000141754M	Blow cover (universal valve)	0000141754	UMS-01067535704	Support block for inner ext guide	01067535704
UMS-0000141758M	Exhaust cover (universal valve)	0000141758	UMS-01067620002	Fixed infeed unit	01067620002
UMS-0000141762	Maintenance kit 970.209.00\$ 141762	0000141762	UMS-01067762801	Roller pin	01067762801
UMS-0000141767M	Universal Blow/Preblow/Rec. adapter W/PV	0000141767	UMS-01067762901	Tie rod	01067762901
UMS-0000141768M	Universal exhaust adapter W/PV	0000141768	UMS-01067763001	Pulling rod pin	01067763001
UMS-0000166002	Maintenance valve piston universal Kit	0000166002	UMS-01067763201	Roller hub	01067763201
UMS-0000226080	Compensation pads	0000226080	UMS-01067763301	Spacer	01067763301
UMS-0000241534	6 pistons maintenance	0000241534	UMS-01067763501	Spacer	01067763501
UMS-01005300202M	S2 Blow nozzle MAC pilot valve conversion	01005300202	UMS-01067763901	Pulling rod pin	01067763901
UMS-01007735801	Spacer	01007735801	UMS-01067788901	Spacer	01067788901
UMS-01008640000	Flexible hose	01008640000	UMS-01068056601	Spring fastening	01068056601
UMS-01008703401	Flexible hose	01008703401	UMS-01068638901	Pin	01068638901
UMS-01008707801	Flexible hose	01008707801	UMS-01068864406M	Transfert arm dual S1 - preform	01068864406
UMS-01060902100	Connecting rod	01060902100	UMS-01068867305M	Transfert arm dual S1 - bottle	01068867305
UMS-01062198300	Pin	01062198300	UMS-01068901902M	Articulation lever	01068901902
UMS-01062694800	Compression spring	01062694800	UMS-01068902202	Plate	01068902202
UMS-01062703900	Ring (washer) for oven chain	01062703900	UMS-01068907202	Spacer	01068907202
UMS-01062984801	S1 SBO16 bottom down cam	01062984801	UMS-01069095301	Spacer	01069095301
UMS-01063444400	Pin	01063444400	UMS-01069166904	Crown	01069166904
UMS-01064586100	Arm S1	01064586100	UMS-01069167801	Inner Ring	01069167801
UMS-01064957500	Compensation stud	01064957500	UMS-01069175001	Spacer	01069175001
UMS-01065055800	Spindle spring	01065055800	UMS-01069175101	Spring	01069175101
UMS-01065289200	Spring	01065289200	UMS-01069215304	Front slide	01069215304
UMS-01065579400M	Shaft (main axle) oven chain S1	01065579400	UMS-01069215403	Slide	01069215403

UMS-01069726203	Orientating plate	01069726203	UMS-01073461101	Grippers set	01073461101
UMS-01069841102	H-Link	01069841102	UMS-01073469101	Preform gripper 30/25	01073469101
UMS-01069841802	Bearing ring	01069841802	UMS-01073644701	Washer	01073644701
UMS-01069842001	Pin	01069842001	UMS-01073673301	Spring	01073673301
UMS-01071043901	Blow nozzle maintenance seals	01071043901	UMS-01073885102	Nozzle spring	01073885102
UMS-01071141401	Spring spacer	01071141401	UMS-01073924102	Dual retainer plate bottom	01073924102
UMS-01071177101	Roller pin	01071177101	UMS-01074126902	S2 DC box	01074126902
UMS-01071334201	S2 SBO20 intermediary shaft	01071334201	UMS-01074160501	Washer	01074160501
UMS-01071398702	Spring	01071398702	UMS-01074257203	Yoke	01074257203
UMS-01071553205	Locking Bar	01071553205	UMS-01074290504	Anti-torque guide	01074290504
UMS-01071553403M	Washer	01071553403	UMS-01074290601	Locking thrust	01074290601
UMS-01071594403	Quick change right infeed magnetic block	01071594403	UMS-01074415802	Spindle tip QC	01074415802
UMS-01071595501	Adapter plate ejection guide infeed wheel	01071595501	UMS-01074598501M	Cylinder	01074598501
UMS-01071607902	Bayonet ring	01071607902	UMS-01074609506	Cylinder neck	01074609506
UMS-01071609203	Support	01071609203	UMS-01074661501	Nozzle with neck-edge support	01074661501
UMS-01071609302	Washer (top)	01071609302	UMS-01074671002M	S2 Ring	01074671002
UMS-01071827802M	S2 SBO20 down cam for stretch rod 1200 mm/s	01071827802	UMS-01074772803M	S2 Cylinder	01074772803
UMS-01071866103	S2 SBO20 bottom down cam	01071866103	UMS-01074772805	Cylinder	01074772805
UMS-01071941801	Mobile infeed unit	01071941801	UMS-01091690001	End piece	01091690001
UMS-01072336802	S2 Stretch rod clamp: inner ring	01072336802	UMS-01111503901	Spindle tip	01111503901
UMS-01072382101	Safety ejection bar	01072382101	UMS-01111616501	S1 SBO6 Station gear	01111616501
UMS-01072474602	Bearing shaft	01072474602	UMS-01111616801	Gear shaft S1 SBO6	01111616801
UMS-01072501105	Fork	01072501105	UMS-01113277601	Ejector	01113277601
UMS-01072501201M	Stainless steel guide pin	01072501201/01125849001	UMS-01113465606M	S2 Cylinder assy	01113465606
UMS-01072505402	Carbon steel ejector pin	01072505402	UMS-01113520504	Cylinder (IRS morganton)	01113520504
UMS-01072508012	Spindle chain link (1 link = 2 spindle tips)	01072508012	UMS-01114702302M	Stopper	01114702302
UMS-01072508012M	Spindle chain link (1 link = 2 spindle tips)	01072508012	UMS-01114876301	Steel pin 7 x 22 mm LG, Pneumatic stellette	01114876301
UMS-01072508302	Concave link without bearing	01072508302	UMS-01115352401	S2 Blow nozzle spring	01115352401
UMS-01072508403	Convex link, without bearing	01072508403	UMS-01115431002	Pipe safety ring S2	01115431002
UMS-01072745602	Bell 80 mm with 62 mm diameter	01072745602	UMS-01115913601	Back plate	01115913601
UMS-01072804901	Thrust	01072804901	UMS-01116191703	Stretch rod clamp	01116191703
UMS-01072912502	Bottle gripper 30/25	01072912502	UMS-01116399001M	Flow restrictor	01116399001
UMS-01072928103M	Stretch rod (heat set)	01072928103	UMS-01116429203	Pneumatic mold base	01116429203/01124451005/ 01124451105/01124526305
UMS-01072948402	Grippers set	01072948402	UMS-01116429804	Piston	01116429804
UMS-01073245401M	Muffler adaptor	01073245401	UMS-01116429903	Top plate	0111642990
UMS-01073311302	S2 dual retainer plate top	01073311302	UMS-01117231501	Mold base locking pin	01117231501
UMS-01073311502	S2 DC machined cover	01073311502	UMS-01118394201A/471	Ejector	01118394201
UMS-01073432602	S2 Compensation bolt	01073432602	UMS-01118394401A	Improved spindle tip	01118394401
UMS-01073432605	Compensation stud-bolt	01073432605	UMS-01118818801M	Spindle tip S2 QC	01118818801

UMS-01122701204	Body	01122701204	UMS-01130488903	Axis roller	01130488903
UMS-01122718902M	Lower right axle	01122718902	UMS-01130647702	Compression spring	01130647702
UMS-01122728903M	Lower left axle	01122728903	UMS-01131136901	Stretch rod stopper	01131136901
UMS-01124042904M	Mold base support (reinforced design)	01124042904	UMS-01131328001	Pin support	01131328001
UMS-01124170905	Pin	01124170905	UMS-01131329102	Pivot pin	01131329102
UMS-01124172201	Anti-torque pin	01124172201	UMS-01131369801	Washer	01131369801
UMS-01124233503	Washer	01124233503	UMS-01131443204M	Blow nozzle 2T D50	01131443204
UMS-01124307602	Inner ring	01124307602	UMS-01131935602	Spring	01131935602
UMS-01124311401	External ring	01124311401	UMS-01131943601	Locking pin	01131943601
UMS-01124311502	External ring	01124311502	UMS-01132220904	Bi-Axis clamp support	01132220904
UMS-01124311601	Internal ring	01124311601	UMS-01132298904	Right clamp support	01132298904
UMS-01124350501	Rod bush	01124350501	UMS-01132304204	Left clamp support	01132304204
UMS-01124352301M	Guiding ring with 2 spaces for seals	01124352301	UMS-01132304602	Spring spacer	01132304602
UMS-01124352301M02	Guiding ring	01124352301	UMS-01132425602	Spindle tip NQC	01132425602
UMS-01124410002	Small plate	01124410002	UMS-01132434501	Transfer arm head stopper	01132434501
UMS-01124410102	Connecting rod	01124410102	UMS-01132781001	Cover	01132781001
UMS-01124452203	Tornado block SBO	01124452203	UMS-01132833301	Roller axis	01132833301
UMS-01124486901	End piece	01124486901	UMS-01133009102	Arm S1	01133009102
UMS-01125203101	Spacer	01125203101	UMS-01133287702	Pin	01133287702
UMS-01125232901	Synthetic roller	01125232901	UMS-01133354502	Fork	01133354502/01160740101
UMS-01126082802	Ejector guide	01126082802	UMS-01133774205	Gripper	01133774205
UMS-01126903902M	Main axle high	01126903902	UMS-01134723601	Spring thrust	01134723601
UMS-01126926801	Tool for wiper seal	01126926801	UMS-01135218101	Cylinder 87.5 mm/34.5 mm	01135218101
UMS-01126933301M	Stretching rod pack diam 14	01126933301	UMS-01135341401	Cylinder neck assy	01135341401
UMS-01126944003M	Improved mold hanger trust right side	01126944003	UMS-01135449601	QC equipped shaft	01135449601
UMS-01126948805	Sleeve	01126948805	UMS-01135548101	Top spring guide	01135548101
UMS-01126949301	Washer	01126949301	UMS-01135548102	Top spring guide	01135548102
UMS-01127012048	Body	01127012048	UMS-01135622901	Ejector	01135622901
UMS-01127190901	Spacer	01127190901	UMS-01136338801	Spring	01136338801
UMS-01127650501	Thrust	01127650501	UMS-01136562103	Bushing	01136562103
UMS-01127838401	Ring steel 16 x 23 x 3 mm	01127838401	UMS-01137435802	Preformed clamp	01137435802
UMS-01128657301	Box	01128657301	UMS-01137481901	Bottle clamp	01137481901
UMS-01128834201	Ring	01128834201	UMS-01138463302	Ejector	01138463302
UMS-01128835304	Ring	01128835304	UMS-01139097501	Gripper	01139097501
UMS-01128896502	Compression spring	01128896502	UMS-01139390801	Universal compensation stud	01139390801
UMS-01128896505	Spring	01128896505	UMS-01139851601	Bushing	01139851601
UMS-01129125503	Pivot axis	01129125503	UMS-01140232401M	Improved mold hanger trust left side	01140232401
UMS-01129714601	Mold base locking pin	01129714601	UMS-01141784601	Gripper	01141784601
UMS-01130347101	Thrust washer	01130347101	UMS-01141784701	Outfeed gripper	01141784701

UMS-01141892301	Preform gripper	01141892301			
UMS-01141892501	Bottle gripper	01141892501			
UMS-01142368902	S2 chain pivot	01142368902/99000011524			
UMS-01143697201A	Grippers 29/25	01143697201			
UMS-01144430202	Roller pin spacer	01144430202			
UMS-01146558401M	Universal pinion fastening	01146558401			
UMS-01146558601M	Universal pinion fastening	01146558601			
UMS-01148300702	Bell end piece	01148300702			
UMS-01148673003	Roller locking pin	01148673003			
UMS-01149109602	Preform gripper	01149109602			
UMS-01149974201	Bearing spacer	01149974201			
UMS-01150398201	Guide ring	01150398201			
UMS-01151132502	Neck rim guide	01151132502			
UMS-01151803901	End Piece	01151803901			
UMS-01152714101	Joint pupm	01152714101			
UMS-01152745501M	Improved universal compensation valve	01152745501			
UMS-01153153601	Gripper PCO 1881	01153153601			
UMS-01153986401	Locking washer	01153986401			
UMS-01155994701	Bottle gripper	01155994701			
UMS-01156606601M	Spindle tip QC 33mm	01156606601			
UMS-01157630702M	Spindle tip 33 mm	01157630702			
UMS-01158380001	Friction washer	01158380001			
UMS-01159125004	Thrust	01159125004			
UMS-01159326101	Preform gripper	01159326101			
UMS-01161584301	Universal gripper	01161584301			
UMS-01161645001	Universal gripper	01161645001			
UMS-01165745302	Compensation box	01165745302			
UMS-01166432901	Bottle gripper	01166432901			
UMS-01168609201	Neck rim retainer	01168609201			
UMS-01169128901	Shoulder guide ring	01169128901			
UMS-01171542003	Quick change left Infeed magnetic block	01171542003			
UMS-04022718701	Dosing clamp FMI	04022718701			
UMS-04250671702	Output turning part	04250671702			
UMS-04299319801M	Filler core	04299319801			
UMS-04307715501	Special screw M7	04307715501			
UMS-04327951402	Rod	04327951402	UMS-99000284586	Axial joint	99000284586
UMS-04342881401	Labeller shell (pair)	04342881401	UMS-99000400393M	Blow valve repair parts	99000400393
UMS-99000052905M	Improved 3-way valve (high flow)	99000052905	UMS-99000411427S	Seals rebuilt S2 air rotary union	99000411427
UMS-99000069227WH	S1 SB0 16/24 water/oil rotary union as assy without head	99000069227	UMS-99000741400	Locking pin (steel)	99000741400

CONTACT INFORMATION

Hubert Pelletier
Business Development
Associate
+1 514-349-2493

Amir Bittar
Vice President Sales
Market Development Specialist
+1 514-962-9052

Robert Saba
Vice President Operations
Commercial Representative
+ 1 514-608-2297

sales@umallette.com

www.um-inc.com



Our partners

